

## Key Cylinder into Ignition Switch

To remove lock and cylinder, insert key into switch assembly position switch in "LOCK" position and insert a large paper clip into upper small hole on cylinder face (see Diagram 1). Push in on paper clip to depress brass spring pin and continue to turn the key counterclockwise until lock cylinder can be removed.

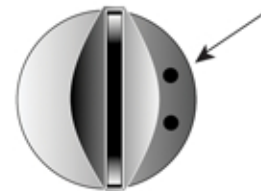

Diagram 1

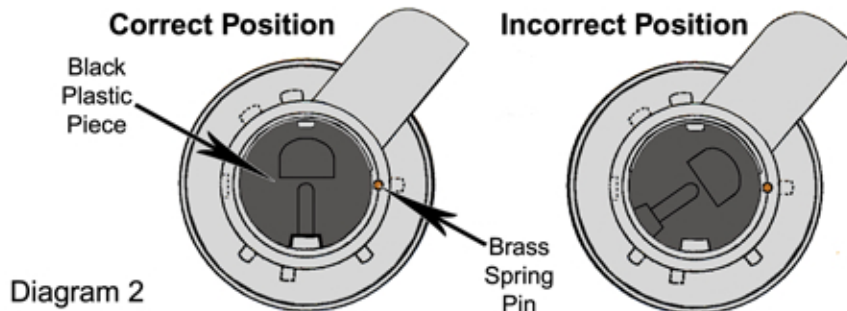
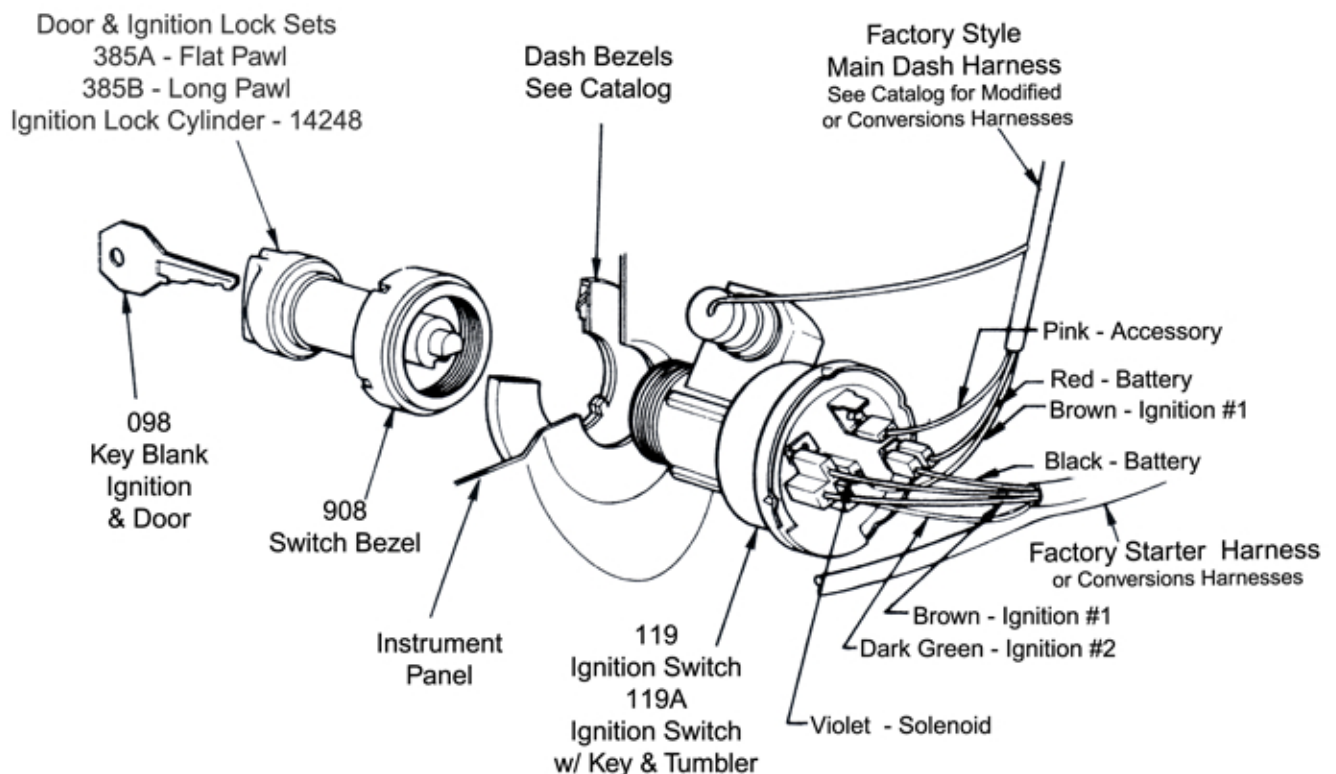

Diagram 2

**NOTE:** There is a black plastic piece within the ignition switch into which the end of the key cylinder fits. This plastic piece must be aligned with its outer metal housing as shown. If it is not aligned properly, insert a screwdriver into the half-moon shaped depression and rotate until it is aligned in the correct position. If the black plastic part is in any other position the key and cylinder will not click into place (see Diagram 2). To install key and tumbler into ignition switch, slide key and tumbler (with key inserted in tumbler) down until it stops and turn clockwise. Reconnect battery.



See # 506 For 1955 and #507 For 1956  
 Passenger Factory Assembly Manual for correct wiring instructions