



QUALITY... PLAIN & SIMPLE®

Flexible Transmission Dipstick Installation Instructions Firewall Mount and Transmount

General Installation Notes:

Please read these instructions completely before beginning the installation. If you have any questions please call.

Before beginning the installation, disconnect the negative battery cable and use wheel chocks to block the vehicle's wheels.

Make sure the engine, transmission, body and frame are properly grounded. We recommend using anti-seize lubricant on all aluminum threads.

NOTE: This dipstick is designed for "push-in" style transmissions. Each transmission dipstick has been calibrated for a specific transmission application. Ford C-4 dipsticks are available for both push into the case or screw into the pan styles.

The firewall mount dipstick is approximately 24" in length, allowing it to be mounted on the firewall or anywhere desired in the engine compartment. The transmount dipstick varies in length according to the transmission application and mounts on the bell housing. The firewall mount is the most versatile and is used where there is little room in the engine compartment. The transmount is recommended for most fenderless vehicles.

NOTE: You will need automotive silicone sealant and a suitable funnel (not supplied) to complete this installation. Firewall mount dipsticks will also need two mounting screws (not supplied).

Refer to Fig. 1 for the component names.

NOTE: DO NOT remove any nuts securing the braided stainless steel hose to the dipstick tube assembly!

- Step 1:** Check the dipstick packaging to make sure you have the correct dipstick for your application.
- Step 2:** If there is an existing grommet or other seal in the dipstick opening in the transmission case that will prevent the new Lokar dipstick tube assembly from fitting into the transmission, remove it. Clean the dipstick opening on the transmission, being sure it is free from all debris or burrs.
- Step 3:** Remove the handle and inner measuring cable from the dipstick tube assembly.
- Step 4:** Make sure the o-rings (or top hat seal on 6L80E & 6L90E dipsticks) are in place on the trans tube fitting. Apply a small bead of automotive silicone sealant (not supplied) around the diameter of the trans tube fitting just below the hex part of the fitting, above the top o-ring (or above the top hat seal).

Flexible Transmission Dipstick Installation Instructions Firewall Mount and Transmount

Building American Quality... With A Lifetime Warranty!®

TOLL FREE 1-877-469-7440 • tech@lokar.com • www.lokar.com

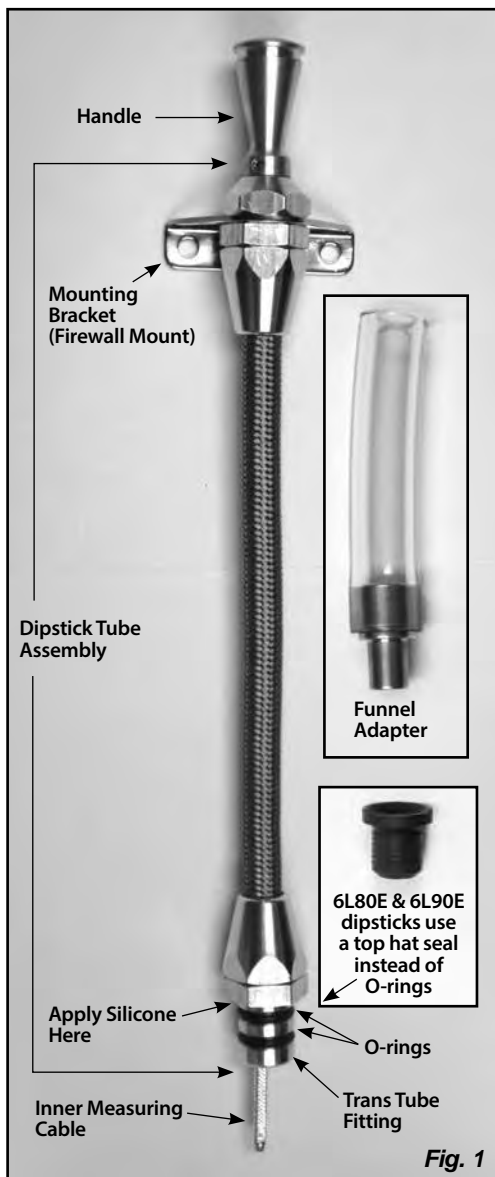

Step 5: Lightly lubricate the o-rings or top hat seal on the trans tube fitting with clean transmission fluid. Push the trans tube fitting into the dipstick opening on the transmission (or on some Ford C4 applications, screw the trans tube fitting into the pan).

NOTE: On Ford C4 case fill transmissions, and on GM 4L60E transmissions, the dipstick tube assembly must be positioned so that the longest flat side of the trans tube fitting is towards the transmission case in order for it to be installed.

Step 6: Firewall Mount: Route the dipstick tube assembly to the desired mounting spot and install the mounting bracket using two screws of your choice (not included).

Transmount: Install the mounting bracket onto the bell housing using the appropriate existing bell housing bolt.

Step 7: Make sure the dipstick tube assembly is not touching the exhaust at any point. Lightly lubricate the o-rings on the dipstick handle with clean transmission fluid. **Fig. 2**

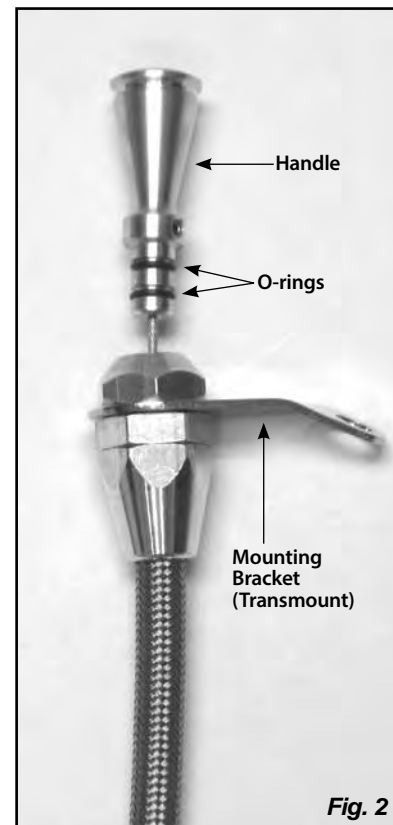

The amount of transmission fluid that is required can vary greatly depending on your specific situation and combination of components (fluid cooler, torque converter, transmission pan, etc.). Check with the manufacturer(s) to determine approximately how much transmission fluid will be required for your particular combination of components.

Using the supplied funnel adapter and an appropriate funnel (not supplied), fill the transmission with the appropriate amount of fluid. **Fig. 3**

Step 8: Follow the transmission manufacturer's recommended procedure for checking and topping off the transmission fluid (engine running or not, fluid hot or cold, shifter in a particular position, etc.). Return the dipstick handle and inner measuring cable into the dipstick housing assembly.

