



AEROMOTIVE Part # 11102 INSTALLATION INSTRUCTIONS



Not For Street Use!

CAUTION:

Installation of this product requires detailed knowledge of automotive systems and repair procedures. We recommend that this installation be carried out by a qualified automotive technician.

Installation of this product requires handling of gasoline. Ensure you are working in a well ventilated area with an approved fire extinguisher nearby. Extinguish all open flames, prohibit smoking and eliminate all sources of ignition in the area of the vehicle before proceeding with the installation.

When installing this product, wear eye goggles and other safety apparel as needed to protect yourself from debris and sprayed gasoline.

WARNING!

The fuel system is under pressure. Do not open the fuel system until the pressure has been relieved. Refer to the appropriate vehicle service manual for the procedure and precautions for relieving the fuel system pressure.

The enclosed Aeromotive fuel pump utilizes an o-ring sealed AN-12 style inlet and outlet ports; these ports are **NOT PIPE THREAD** and utilize **NO THREAD SEALANT**.

A high capacity fuel filter must be installed between the fuel tank and pump inlet. We recommend an Aeromotive P/N 12302. Call us for info.

To use this pump in your vehicle's fuel system, we strongly recommend the following:

Gravity feed the pump by mounting it lower than and as close as possible to the fuel tank.
If you are using a stock fuel tank, install a reservoir style sump in the bottom-rear of your fuel tank. Exercise extreme caution and follow all manufacturer's recommendations when installing a reservoir style sump.

Utilize AN-12 size high pressure fuel lines, fittings and o-rings for all connections from the fuel tank pickup to the fuel rails in the engine compartment.

Failure to follow the above recommendations may result in fuel leakage, bursting of the fuel lines, poor vehicle performance and/or decreased fuel pump life! Improper installation will void all warranties for this product!

Aeromotive system components are not legal for sale or use on emission controlled motor vehicles.

Performance Specifications: Model 11102

Fuel Compatibility
Port Sizes

Gasoline ONLY (Not compatible with alcohol based fuel additives)
Inlet & Outlet AN-12

The following steps are typical of most installations:

1. Once the engine has been allowed to cool, relieve the fuel system pressure and disconnect the negative battery cable.
2. Raise the vehicle and support it with jack stands.
3. Referring to the appropriate vehicle service manual for instructions, remove the OEM fuel pump.
4. Install an after-market fuel tank sump kit, per the manufacturer's instructions.

Note: Failure to mount the pump lower than and close to the fuel tank may cause the pump to run dry, resulting in extreme pump wear! Make sure the pump is located lower than and as close as possible to the fuel tank, so that the pump is always supplied with fuel!

5. Find a suitable place on the vehicle chassis to mount the Aeromotive fuel pump. Make sure the location will accommodate the pump mounting bolts, will position the pump lower than the fuel tank, is clear of the exhaust, is clear of any moving suspension or drivetrain components and will keep the pump clear of road obstructions or debris.
6. Using the enclosed template, mark and drill four mounting holes to accept 1/4" bolts. Mount the fuel pump using four 1/4" bolts, nuts and lock washers.

Note: Be sure to route all fuel lines clear of any moving suspension or drivetrain components, and any exhaust components! Protect fuel lines from abrasion and road obstructions or debris.

7. Connect the fuel tank sump to the fuel filter inlet and the fuel filter outlet to the fuel pump inlet.
8. Connect the fuel pump outlet to the vehicle's fuel rails in the engine compartment. **Make sure you use high pressure (200 psi minimum) fuel line for this connection!**

Note: Be sure to route all electrical wires clear of any moving suspension or drivetrain components and any exhaust components! Protect wires from abrasion and road obstructions or debris.

9. There are several ways to connect electrical power to the pump, depending on your fuel injection system. Make sure you use stranded, insulated copper wire, in the sizes shown, with matching crimp-type connectors for all connections.
10. Attach the OEM fuel pump wires, the aftermarket ECM fuel pump wires or your fuel pump switch wires as shown in the following diagram.

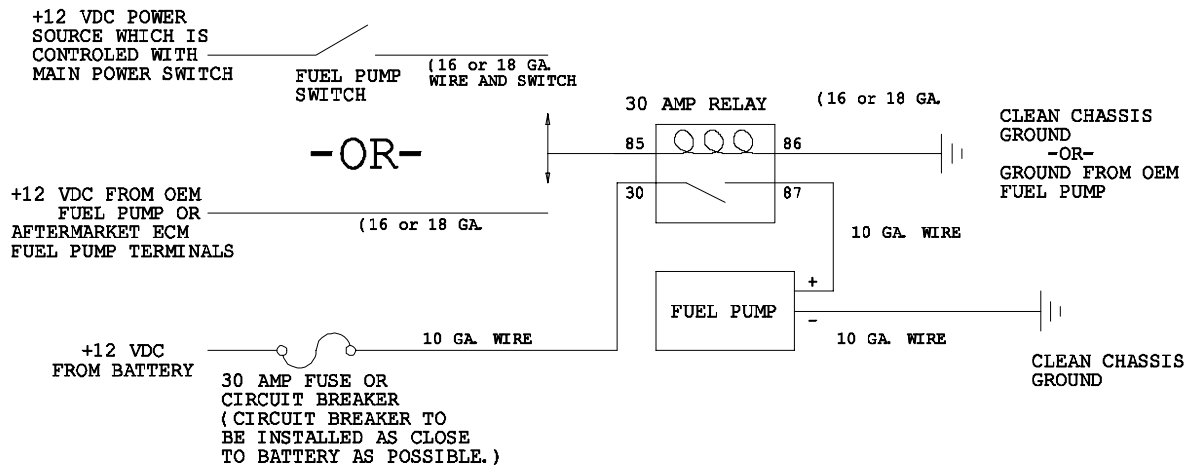

11. Attach a suitable fuel pressure gauge to the fuel system schrader valve, fuel rail or fuel pressure regulator.

12. Ensure that any spilled fuel and any fuel soaked shop towels are cleaned up and removed from the vicinity of the vehicle!

CAUTION: While performing the following steps, if any fuel leaks are detected, immediately turn the ignition to OFF, remove any spilled fuel and repair the leak(s) before proceeding!

13. Turn the ignition to ON **without starting the engine**, allow the pump to run for several seconds and check the fuel pressure. If there is no pressure, turn the ignition to OFF, wait one minute, then turn the ignition to ON and recheck the pressure. Repeat this ignition OFF and ON procedure until the gauge registers pressure or you detect a fuel leak. If no pressure is registered on the gauge after running the pump for several seconds and you have found no leaks, check all fuel and electrical connections to determine the cause.

14. Once the fuel pressure gauge registers pressure, start the engine. The fuel pressure gauge should register between 40 and 70 psi. If you have installed an adjustable fuel pressure regulator, adjust it to the desired setting. (For maximum fuel system performance, we recommend using an Aeromotive adjustable fuel pressure regulator; call us for info.)

15. Shut the engine off. Using suitable clips and other mounting hardware, secure the newly installed fuel lines and electrical wires by attaching them to the vehicle chassis.

16. Carefully lower the vehicle to the ground.

17. Test drive the vehicle to insure proper operation and re-check the fuel system for leaks. **If any leaks are found, immediately discontinue use of the vehicle and repair the leak(s)!**

Patent Pending

Thanks for purchasing another quality product designed, engineered and manufactured in
Kansas City, USA!

AEROMOTIVE, INC.
7805 Barton Street, Lenexa, KS 66214
913-647-7300 fax 913-647-7207

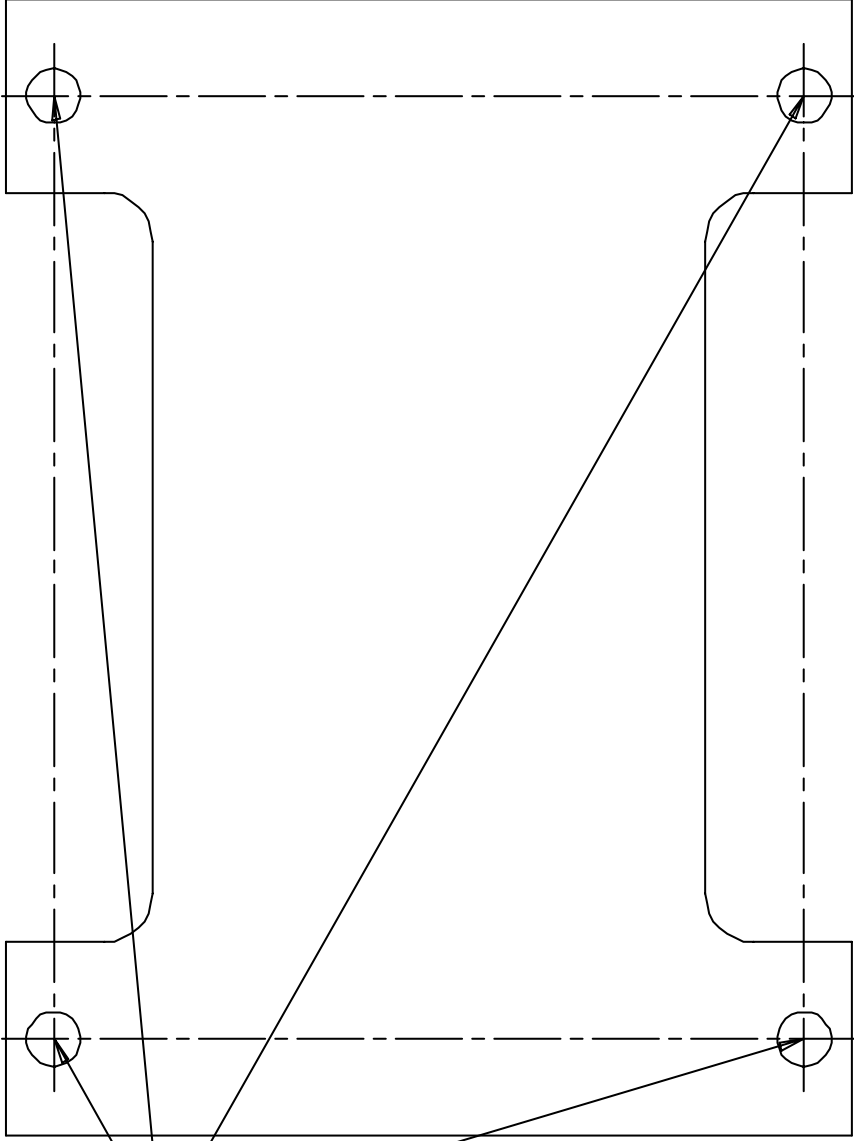

**DRILL 4 HOLES TO
ACCEPT 1/4" BOLTS**

AEROMOTIVE, INC. LIMITED WARRANTY

This Aeromotive Product, with proof of purchase dated on or after January 1, 2003, is warranted to be free from defects in materials and workmanship for a period of one year from the original date of purchase. No warranty claim will be valid without authentic, dated proof of purchase.

This warranty is to the original retail purchaser and none other and is available directly from Aeromotive and not through any point of distribution or purchase.

If a defect is suspected, the retail purchaser must contact Aeromotive directly to discuss the problem, possible solutions and obtain a Return Goods Authorization (RGA), if deemed necessary by the company. Please call 913-647-7300 and dial option 3 for the technical service dept. All returns must be shipped freight pre-paid to the company and with valid RGA before they will be processed.

Aeromotive will examine any product returned with the proper authorization to determine if the failure resulted from a defect or from abuse, improper installation, misapplication or alteration. Aeromotive will then, at it's sole discretion, return, repair or replace the product.

If any Aeromotive product is determined defective, buyer's exclusive remedy is limited in value to the sale price of the good. In no event shall Aeromotive be liable for incidental or consequential damages.

Aeromotive expressly retains the right to make changes and improvements in any product it manufactures and sells at any time. These changes and improvements may be made without notice at any time and without any obligation to change the catalogs or printed materials.

Aeromotive expressly retains the right to discontinue at any time and without notice any Aeromotive product that it manufactures or sells.

This warranty is limited and expressly limits any implied warranty to one year from the date of the original retail purchase on all Aeromotive products.

No person, party or corporate entity other than Aeromotive shall have the right to: determine whether or not this Limited Warranty is applicable to any Aeromotive product, authorize any action whatsoever under the terms and conditions of this Limited Warranty, assume any obligation or liability of any nature whatsoever on behalf of Aeromotive under the terms and conditions of this Limited Warranty.

This Limited Warranty covers only the product itself and not the cost of installation or removal.

This Limited Warranty is in lieu of and expressly excludes any and all other warranties, expressed or implied. This Limited Warranty gives you specific legal rights, and you may also have other rights which vary from state to state.