

P/N SUM-760152

Parts List

4' – 3/8" Vacuum Hose	4 – 1/4" Lock Washer
1 – Vacuum Pump Assembly	4 – 1/4" Nut
4 – 1/4" x 1" SHCS	8 – 1/4" Flat Washer

Electric Vacuum Pump Instructions

These instructions are a basic guideline for installing an Electric Vacuum Assist. This pump comes with a built-in factory set vacuum switch.

Installation

Before you begin use the rubber insulators to mount unit to the vehicle. Unit can be mounted in any position.

Electrical Installation

The BLUE wire on the supplied wiring harness goes to +12VDC. The connection to positive (+) must be ignition switched power so that when the motor is switched off the Vacuum Pump is off. The circuit used for this connection must have at least a 15 amp fuse in the car's fusebox. The BLACK wire to chassis ground or -12VDC.

Vacuum Circuit

A Supplied hose is used to connect the vacuum pump intake nozzle to the brake vacuum booster or servo unit. Note: Vacuum pump should be installed in-line between the engine vacuum and the brake booster/servo unit. Vacuum port is for the brake booster and the engine / outlet is for engine vacuum.

Troubleshooting

If pump keeps cycling – possible vacuum leak – remove hose from intake vacuum, place finger over vacuum port, hold firmly, vacuum pump should turn off and stay off.

Possible Cause: Vacuum leak in hose or vacuum booster itself.

Replace defective items and reinstall.

Customers in higher altitudes may require an adjustment of the vacuum switch when the pump does not shut off.

CAUTION: Adjusting this switch does not increase vacuum output – it will only effect the turn on and turn off setpoint. A vacuum gauge must be used when adjusting this switch. Over adjusting of the switch could cause damage to internal components.

On the back of the vacuum switch there is a 1/8" Allen plug – remove it. Behind the plug is a 1/8" adjustment screw. Using a 1/8" Allen key, turn the screw clockwise to decrease the vacuum setpoint and counterclockwise to increase the vacuum setpoint

OPTION #1

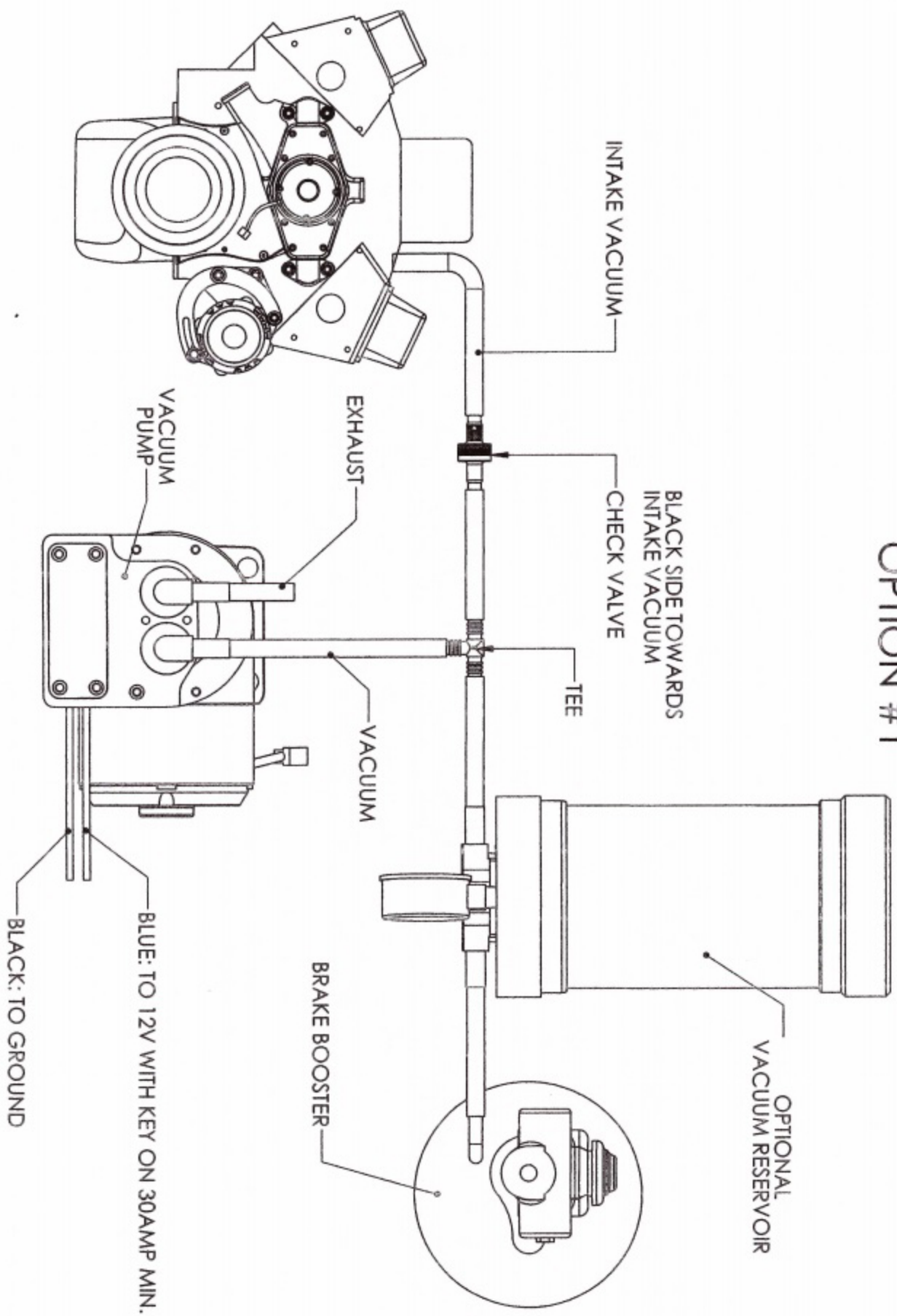

OPTION #2

