



MS2/V3.0 Hardware Manual

Megasquirt-2 Product Range

MS2/Extra 3.4.x

Dated: 2016-01-15

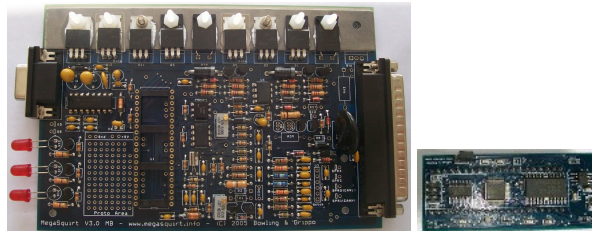

Hardware manual covering specific wiring and configuration of your Megasquirt MS2/V30 ECU.

This version of the documentation applies to:

- MS2 on a V3.0 mainboard as shown above running firmware MS2/Extra 3.4.x
(See the Setting Up manual for more detail on version numbers.)

Does not apply to other Megasquirt products or other firmware versions.

Table of Chapters

1 Introduction.....	7
2 Megasquirt System Hardware.....	9
3 Wiring.....	11
4 Fuel System.....	46
5 Ignition System - fundamentals.....	58
6 Ignition system - specific operating modes.....	98
7 Throttles.....	163
8 Optional Hardware.....	164
9 Example wiring.....	164
10 Further information.....	166
11 Appendix A Schematics.....	166
12 Appendix B: junkyard guide to finding EDIS.....	179
13 Appendix C: V3.0 Board Assembly.....	184
14 Revision history.....	201

Contents

1	Introduction.....	7
1.1	Emissions and disclaimer.....	7
1.2	Required tools.....	7
1.3	How to use this manual.....	7
2	Megasquirt System Hardware.....	9
2.1	Overview.....	9
2.2	Megasquirt Installation.....	9
2.3	Wiring Harness and fuses.....	10
2.4	Crank / Cam Inputs.....	10
2.5	Sensor Inputs.....	10
2.6	Outputs.....	10
2.7	Tuning interface.....	10
3	Wiring.....	11
3.1	Best Practices.....	11
3.1.1	Wire and connector choice.....	11
3.1.2	Soldering or crimping.....	11
3.1.3	Re-pinning the DB37.....	11
3.1.4	Fusing.....	11
3.1.5	Four-pin relay pin-out note.....	11
3.1.6	Relay and accessory power routing.....	11
3.2	Grounding (Earthing) Schemes.....	12
3.3	Core Wiring Diagram.....	13
3.3.1	Optional Connections.....	13
3.3.2	Relay Board.....	16
3.4	Inputs.....	18
3.4.1	Crank and Cam Tach inputs.....	18
3.4.2	MAP (Manifold Absolute Pressure) sensor.....	18
3.4.3	IAT/MAT (Intake/Manifold Air Temperature) sensor.....	19
3.4.4	CLT (Coolant Temperature) sensor.....	22
3.4.5	TPS (Throttle Position Sensor).....	23
3.4.6	O2 (Oxygen) Sensor / Lambda Sensor.....	23
3.4.7	MAF (Mass Air Flow) Sensor.....	25
3.4.8	Flex / Switch input.....	29
3.4.9	Spare ADCs / Switch inputs.....	31
3.4.10	B/LD boot jumper.....	33
3.4.11	CAN comms.....	34
3.4.12	Knock sensor.....	34
3.5	Outputs.....	36
3.5.1	Fuel Injector outputs.....	36
3.5.2	Ignition outputs.....	36
3.5.3	Fuel pump output.....	36
3.5.4	Idle valve.....	37
3.5.5	Tacho output.....	41
3.5.6	Other relay outputs.....	42

3.5.7 Boost control output.....	42
3.6 Inputs and Outputs Summary.....	43
3.6.1 Pin vs. feature table.....	44
3.7 Bench test wiring.....	44
3.7.1 Minimal connection.....	44
3.7.2 JimStim connection.....	45
4 Fuel System.....	46
4.1 Introduction.....	46
4.1.1 Existing EFI Vehicle.....	47
4.1.2 Retro-fit EFI Vehicle.....	47
4.2 Single Fuel pump.....	47
4.3 Low pressure / high pressure - twin pump.....	47
4.4 Wiring the Fuel Pump.....	48
4.5 Fuel Line.....	48
4.6 Fuel filter.....	49
4.7 Fuel Pressure Regulator.....	49
4.8 Injector installation.....	50
4.9 Fuel Rails.....	50
4.10 Fuel Injectors.....	50
4.10.1 Injector Size.....	50
4.10.2 Injector Impedance and wiring.....	52
4.10.3 Staged injection.....	55
4.10.4 Sequential injection 'mod'.....	55
5 Ignition System - fundamentals.....	58
5.1 Ignition system design.....	58
5.2 Crank and Cam tach inputs.....	58
5.2.1 Coil Negative Input.....	59
5.2.2 VR (magnetic) sensor input.....	60
5.2.3 Hall sensor input.....	62
5.2.4 Hall sensor input (built-in pull-up).....	66
5.2.5 Gear-tooth sensor input.....	68
5.2.6 GM LS 24X crank/cam sensors.....	68
5.2.7 GM LS 58X crank/cam sensors.....	69
5.2.8 Optical sensor.....	70
5.2.9 Distributor points input.....	70
5.2.10 Combined Ignition module (TFI, EDIS, HEI, GMDIS).....	71
5.2.11 Nissan CAS.....	71
5.2.12 4G63 / 6G72.....	72
5.2.13 Mitsubishi CAS with aftermarket disc.....	73
5.2.14 Adding a cam sensor input.....	73
5.3 Ignition outputs.....	75
5.3.1 Building ignition outputs.....	76
5.3.2 Logic coils.....	80
5.3.3 Amplifiers (ignitor, power transistor, ignition module).....	88
5.3.4 High current coils.....	93
5.3.5 CDI modules (e.g. MSD, Crane etc.).....	94
5.3.6 Mazda Rotary ignition wiring.....	95

5.3.7 Toyota DLI ignition wiring.....	96
6 Ignition system - specific operating modes.....	98
6.1 Coil negative for fuel only.....	99
6.2 Distributor pickup.....	100
6.2.1 Traditional vac/mech distributor.....	100
6.2.2 Rotor / Output phasing - all distributor installs.....	104
6.2.3 Distributor with hall/optical 'trigger return'.....	105
6.2.4 Distributor with basic crank trigger.....	106
6.2.5 Distributor with crank trigger wheel.....	107
6.3 Ford TFI.....	107
6.4 GM HEI7.....	109
6.5 GM HEI8.....	111
6.6 Dual Sync Distributor.....	112
6.7 Ford EDIS.....	112
6.7.1 System components.....	112
6.7.2 ECU wiring.....	113
6.7.3 Module wiring.....	114
6.7.4 36-1 trigger wheel and VR sensor.....	116
6.7.5 Checking the timing.....	120
6.8 GM DIS (for reference only).....	120
6.9 Toothed Wheel.....	121
6.9.1 Wheel combinations.....	121
6.9.2 Terminology notes.....	122
6.9.3 Wheel naming.....	123
6.9.4 Retrofit install.....	124
6.9.5 Existing install.....	125
6.9.6 Missing tooth crank wheel.....	125
6.9.7 Missing tooth cam wheel.....	127
6.9.8 Missing tooth crank wheel and single tooth cam wheel.....	127
6.9.9 Missing tooth crank wheel and polled cam wheel.....	130
6.9.10 Nippondenso CAS.....	134
6.9.11 Non-missing tooth crank wheel with one cam tooth.....	139
6.9.12 Mitsubishi CAS with aftermarket disc - single coil / wasted spark.....	142
6.9.13 Mitsubishi CAS with aftermarket disc - coil-on-plug.....	143
6.9.14 Other wheel arrangements.....	144
6.9.15 Example: Ford Zetec.....	144
6.10 Neon/420A.....	145
6.11 36-2+2 (NGC).....	147
6.12 36-2-2-2.....	148
6.13 Miata 99-05.....	149
6.14 Subaru 6/7.....	150
6.15 6G72.....	150
6.16 IAW Weber.....	151
6.17 Mitsubishi CAS 4/1.....	152
6.18 Mitsubishi 4G63 (and Miata).....	152
6.19 Twin trigger.....	154
6.20 Chrysler 2.2/2.5.....	155

6.21 Renix 44-2-2 (66-2-2-2).....	155
6.22 Suzuki Swift.....	155
6.23 Suzuki Vitara 2.0.....	156
6.24 Daihatsu 3cyl.....	156
6.25 Daihatsu 4cyl.....	156
6.26 VTR1000.....	157
6.27 Rover#1.....	157
6.28 Rover#2.....	157
6.29 Rover#3.....	158
6.30 GM7X.....	158
6.31 QR25DE.....	158
6.32 Honda RC51.....	158
6.33 GM LS1 (24X).....	159
6.34 GM LS2 (58X).....	160
6.35 YZF1000.....	161
6.36 HD 32-2.....	161
6.37 Miata 36-2.....	162
7 Throttles.....	163
8 Optional Hardware.....	164
8.1 Expansion boards.....	164
9 Example wiring.....	164
9.1 Nitrous.....	164
9.2 Component pinouts.....	165
10 Further information.....	166
11 Appendix A Schematics.....	166
12 Appendix B: junkyard guide to finding EDIS.....	179
12.1 North America - EDIS4.....	179
12.2 Europe - EDIS4.....	180
12.3 Europe - EDIS6.....	182
12.4 Europe - EDIS8.....	182
12.5 Europe - 36-1 trigger disc.....	182
12.6 Europe - VR sensor.....	183
12.7 World - Coilpack(s).....	183
13 Appendix C: V3.0 Board Assembly.....	184
13.1 Introduction.....	184
13.2 Build choices.....	184
13.3 Assembly.....	185
13.4 Jumper wires.....	192
13.5 Testing Stage.....	194
13.6 Optional low-z injector PWM modification.....	196
13.7 Bill of Materials (parts list).....	196
14 Revision history.....	201

1 Introduction

The MS2/V3.0 is an ECU based on Megasquirt-2 technology, consisting internally of an MS2 card installed on a through-hole DIY V3.0 mainboard. This manual covers MS2/V3.0 specific installation details and should be used in conjunction with the general Setting up and TunerStudio reference manuals.

1.1 Emissions and disclaimer

All parts are sold for OFF ROAD RACE-ONLY ground-vehicle use only, or vehicles that pre-date any federal and state emissions control requirements. Aftermarket EFI/EMS systems are not for sale or use on pollution controlled vehicles. Alteration of emission related components constitutes tampering under the US EPA guidelines and can lead to substantial fines and penalties. Your country/state/district may also have specific rules restricting your tampering with your vehicle's emissions system.

Race parts are inherently dangerous and may cause injury or damage if improperly modified or altered before use. The publishers of this manual will not be held liable for and will not pay you for any injuries or damage caused by misuse, modification, redesign, or alternation of any of our products. The publishers of this manual will not be held in any way responsible for any incidental or consequential damages including direct or indirect labor, towing, lodging, garage, repair, medical, or legal expense in any way attributable to the use of any item in our catalog or to the delay or inconvenience caused by the necessity of replacing or repairing any such item.

1.2 Required tools

Tuning laptop
Stroboscopic timing light
Multi-meter (volts, ohms)
Screwdrivers
Wire cutters
Terminal crimpers
Soldering iron and solder
Heat-shrink tubing
Fire extinguisher

Although not essential, the following are highly recommended:

Oscilloscope or scope-meter or soundcard scope
Test light
Power probe

1.3 How to use this manual

Customers new to EFI are advised to read all of sections 1-5 as these cover some fundamental concepts and give an overview of how to connect up the various EFI components.

More experienced customers can likely skim through sections 1-5.

Section 3.3 is the external wiring diagram, you should print that out.

Section 6 covers the many different tach trigger input schemes (wheel decoders) that exist to support numerous OEM trigger wheel patterns. Find the section that is appropriate for your engine and read that one.

This guide includes a number of notes which are indicated as follows:



This symbol indicates an “Information” note.



This symbol indicates a “Caution” note.



This symbol indicates a “Warning” note.

Installing or tuning your Megasquirt incorrectly can potentially cause damage to your engine, the Megasquirt or external hardware. Warning notes indicate specific areas where you need to exercise extreme care.

Do not rely on these warnings as your only criteria for taking care !

For additional help and support, visit the website www.msextra.com

2 Megasquirt System Hardware

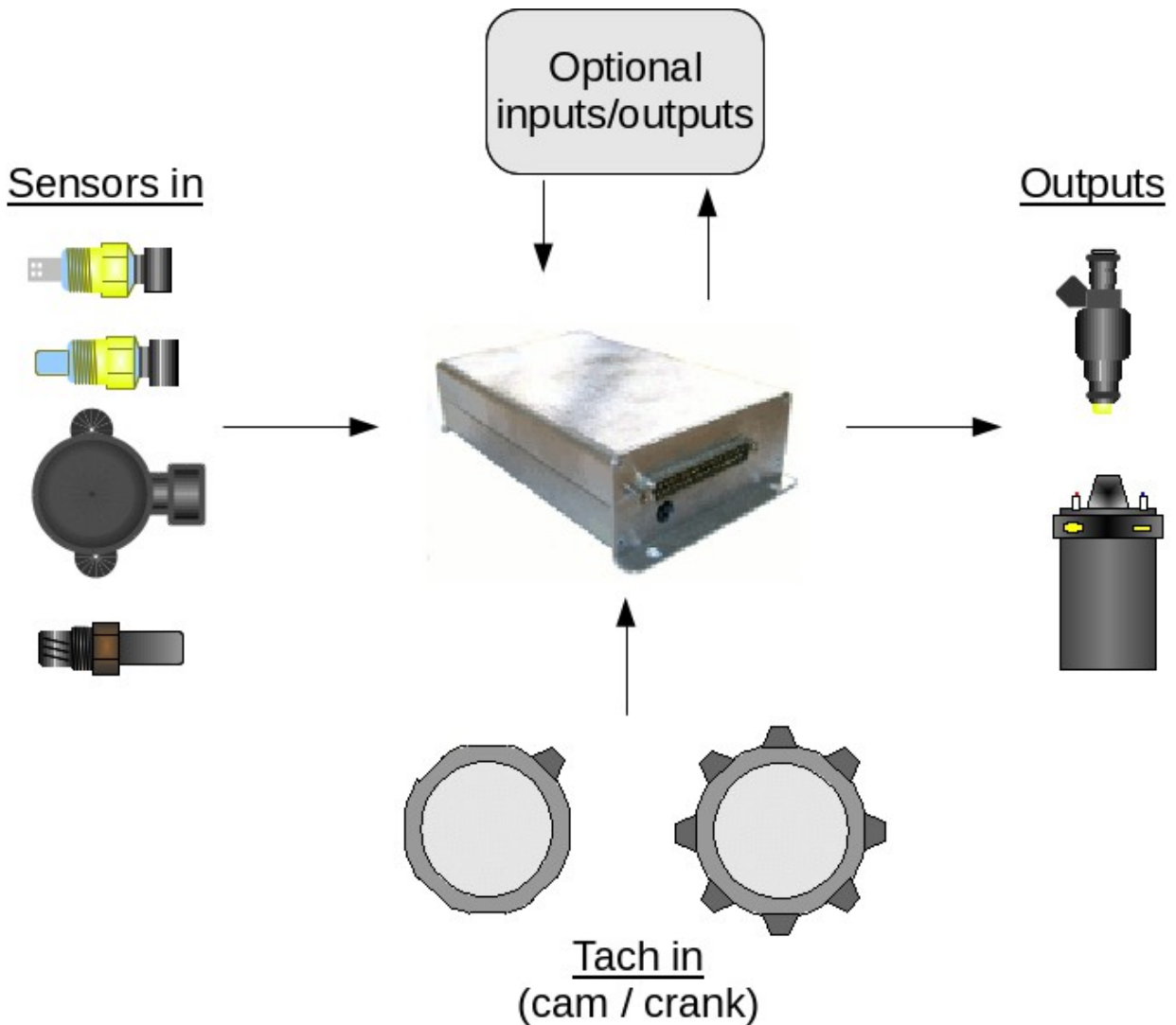

2.1 Overview

The Megasquirt engine control unit (ECU) receives signals from the various input sensors and then controls the fuel and spark outputs to run the engine.

For engines that already have fuel injection installed, you will likely be able to re-use many of the existing sensors and output hardware.

For engines that do not have existing fuel injection, review the available options in this manual and select the most suitable components to complete your install.

2.2 Megasquirt Installation

The Megasquirt is not designed to be installed in the engine compartment. Typically it will be installed under the dash in a car or under the seat on a bike - but away from direct engine temperatures. The temperature must not exceed 185°F (85°C.) It should be protected from water.

2.3 Wiring Harness and fuses

The Megasquirt can be supplied with a "pigtail" wiring harness to form the basis of your own wiring.

2.4 Crank / Cam Inputs

The Crank and Cam sensors provide the Megasquirt with engine position information which is critical for ignition timing. Fuel-only installs will often take a signal from an existing inductive ignition coil.

2.5 Sensor Inputs

The sensor inputs provide the ECU with information about current engine operating conditions and are used to calculate the fuel and spark outputs.

The primary inputs are MAP sensor, MAT sensor, CLT sensor, TPS and O2 input.

2.6 Outputs

Based on the crank/cam and sensor inputs the Megasquirt calculates the required fuel and spark outputs.

2.7 Tuning interface

The Megasquirt uses an RS232 interface for tuning. This is provided as a standard DB9 serial connector. Your computer will likely require a USB-serial adapter also - adapter cables based on the FTDI chipset are recommended. Some customers have reported unreliability with Prolific based cables.

Megasquirt also has CAN communications for connection to add-on modules or dashes.

3 Wiring

A main step in your Megasquirt installation is connecting up the wiring. Be sure to follow the guidance here to avoid common mistakes that will often lead to problems.

3.1 Best Practices

3.1.1 Wire and connector choice

For many first-time users, it may be tempting to re-use old connectors and wiring. While this may sometimes be cost-effective, beware of false economy. Using fresh connectors and suitable automotive grade wiring can save many a headache. Be particularly aware of using wire or components that are not temperature rated high enough, engines get HOT and the insulation on sub-standard wires can melt or degrade leading to erratic connections or short circuits. All components must be rated for 105°C / 220°F as a minimum.

There are many suppliers dedicated to supplying the required items to construct wiring harnesses.

3.1.2 Soldering or crimping

This is mainly down to personal choice, some installers prefer a soldered joint, others swear that crimped connections are superior. The key task is to make a reliable connection.

In your wiring harness you will need to ensure that all joints are effective both electrically and mechanically. Always test by tugging on the wires to ensure that they are not loose. Use heat-shrink tubing over connections to insulate them and prevent shorts.

Don't even think about using scotch blocks - they are bad enough for installing a radio or trailer plug!

3.1.3 Re-pinning the DB37

Optionally, to create the smallest wiring harness possible, the DB37 connector in a pre-made loom can have any unused spare wires removed.

3.1.4 Fusing

It is required that the system be fused - as shown in the general wiring diagram. Remember that an automotive battery is capable of supplying hundreds of amps into a short circuit which can easily melt wires or start a fire. Appropriate fuses can help reduce this risk and save component damage.

If there is a risk of the connections becoming damp then it can be worth applying petroleum jelly (e.g. Vaseline) to the connections to slow the corrosion.

3.1.5 Four-pin relay pin-out note

Be aware that there are two incompatible "standards" for four-pin automotive relays. Mixing them up will usually cause a short-circuit in your wiring harness. The type where pin 85 is opposite 86 is preferred as this is the same as 5-pin relays.

3.1.6 Relay and accessory power routing

Any relays, solenoids or lamps operated by the Megasquirt must only be powered when the Megasquirt is on. Typically it is easiest to take their power from the "fuel pump relay" so they are only powered when the engine is running. Miswiring accessories can cause power to backfeed into the Megasquirt causing unexpected behavior such as running-on.

3.2 Grounding (Earthing) Schemes



Implementing a correct grounding scheme is critical to a successful Megasquirt install.

Connecting sensors to the wrong ground, using corroded ground points or dubious original wiring are sure-fire ways to give you a headache.

There are two key rules:

1. All sensors must ground at the Megasquirt
2. Ground the Megasquirt at the engine block/head using both available ground wires.

Reasoning:

When a current flows through a wire there is always a voltage drop, the bigger the current, the bigger the drop (this is ohm's law.) During cranking there is a very large current flowing through the ground strap from battery to engine and perhaps a few volts may be dropped across it. Even during running, a number of amps will flow through the Megasquirt grounds to the engine.

The sensors (coolant, air temp, throttle position, wideband, tach input) all use low current, low voltage signals. The Megasquirt measures the voltage from the sensor and converts it into a temperature, position etc. reading. If that sensor is grounded to anything other than the Megasquirt itself, then that input voltage will be altered by any external voltage drops. For a sensitive measurement such as AFR (lambda) this can be a real problem. All good wideband controllers offer a high-current ground (connects to engine) and a sensor/signal ground (connects to Megasquirt.)

Tach input (e.g. crank, cam sensors) will be even worse - they can show false or missed teeth and cause sync-loss due to the ground voltage difference.

The following two diagrams illustrate good and bad wiring schemes showing where the troublesome voltage drops are created and how that would cause sensor readings to be garbage.

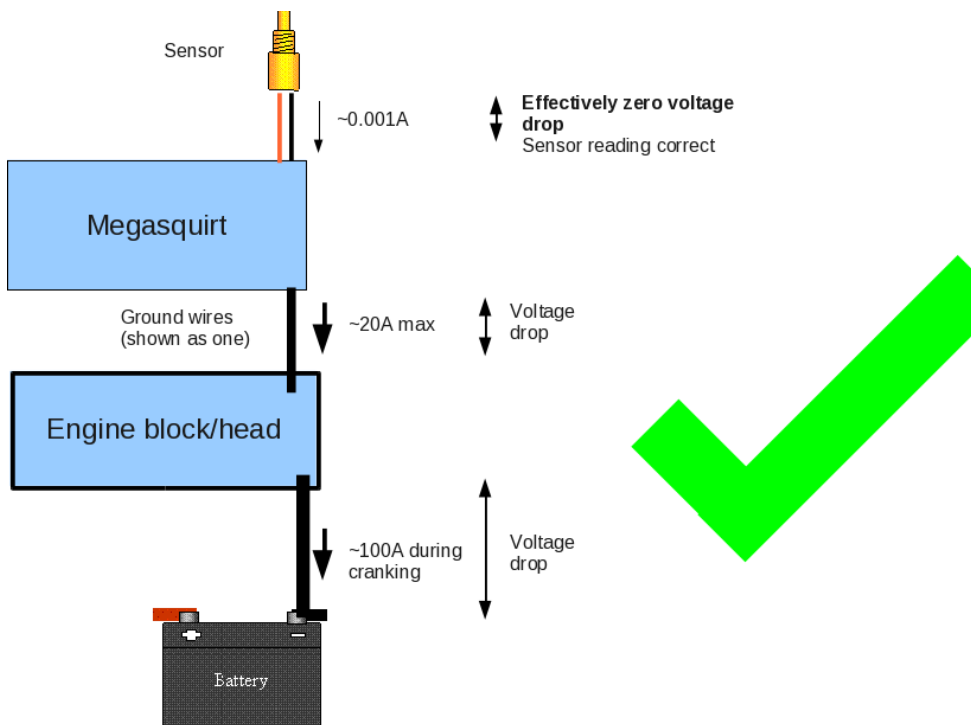

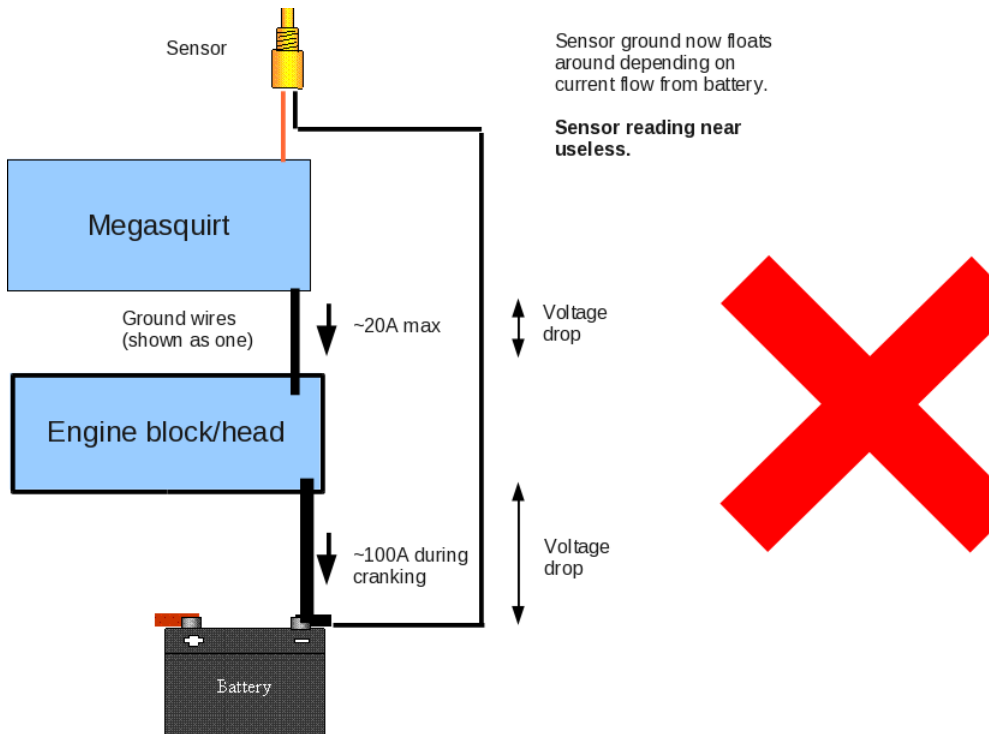

If re-using or splicing into OEM wiring, do not assume that their wiring is OK. Always follow the above principles.

As a check, with the Megasquirt connector unplugged, ensure that the sensor grounds have no continuity to engine/body ground. Your sensor readings will be junk if they do have continuity - the sensors must ground at the Megasquirt **only**.

3.3 Core Wiring Diagram

Refer to diagram on next page.

3.3.1 Optional Connections

The following wiring diagram and table show a number of functions in braces (). These indicate optional connections. These must be connected internally by you (or the ECU builder) and may be different depending on builder. Double check how you assembled it or ask your builder.

SPR1, SPR2 are typically used as CANH, CANL (JS6, JS8)

SPR3, SPR4 have no standard function and are spare

IAC1A, IAC1B, IAC2A, IAC2B are typically connected to the stepper outputs from the MS2 card.

FIDLE as standard is only suitable for switching a relay. To use it with a 2-wire PWM idle valve the transistor on the mainboard needs upgrading. This is covered later.

IGN is typically connected internally to a high-current ignition driver (BIP373)

All of the GND pins are connected internally, the wiring here is recommended.

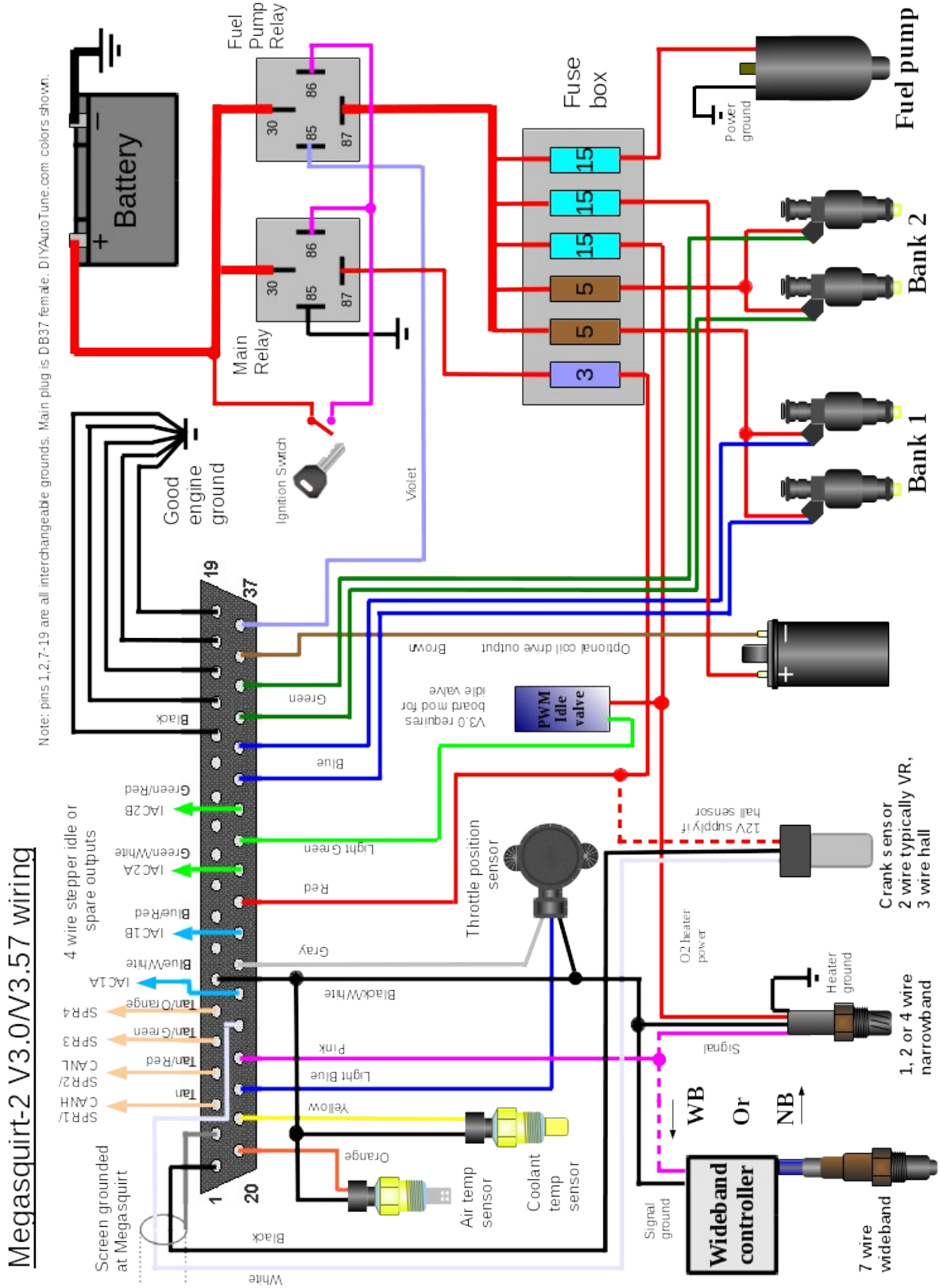

Main plug (DIYAutoTune.com colors)

Pin#	Name	Color	In/Out	Function	Max amps
1	GND	Black	GND	Crank sensor ground	-
2	GND	-	GND	Crank sensor shield	-
3	SPR1	Tan	(Comms)	(CANH)	-
4	SPR2	Tan/Red	(Comms)	(CANL)	-
5	SPR3	Tan/Green	-	spare	-
6	SPR4	Tan/Orange	-	spare	-
7	GND	Black/White	GND	Sensor ground	-
8	GND	-	GND	spare GND	-
9	GND	-	GND	spare GND	-
10	GND	-	GND	spare GND	-
11	GND	-	GND	spare GND	-
12	GND	-	GND	spare GND	-
13	GND	-	GND	spare GND	-
14	GND	-	GND	spare GND	-
15	GND	Black	GND	POWER GROUND	-
16	GND	Black	GND	POWER GROUND	-
17	GND	Black	GND	POWER GROUND	-
18	GND	Black	GND	POWER GROUND	-
19	GND	Black	GND	POWER GROUND	-
20	MAT	Orange	In	MAT sensor input	-
21	CLT	Yellow	In	CLT sensor input	-
22	TPS	Light Blue	In	TP Sensor input	-
23	O2	Pink	In	Oxygen/lambda sensor in	-
24	TACH IN	White in shielded wire	In	'Crank' Tach input	-
25	IAC1A	Blue/White	(Out)	(IAC1A)	0.5A
26	TPSVREF 5V	Gray	Out	5V supply for TPS	0.1A
27	IAC1B	Blue/Red	(Out)	(IAC1B)	0.5A
28	+12V In	Red	In	Main power feed	< 1A
29	IAC2A	Green/White	(Out)	(IAC2A)	0.5A
30	FIDLE	Light Green	Out	Idle valve output	0.1A *
31	IAC2B	Green/Red	(Out)	(IAC2B)	0.5A
32	INJ1	Blue	Out	Injector bank 1 output	7A
33	INJ1	Blue	Out	Injector bank 1 output	7A
34	INJ2	Green	Out	Injector bank 2 output	7A
35	INJ2	Green	Out	Injector bank 2 output	7A
36	IGN	Brown	(Out)	(High current ignition)	7A
37	FP (Pump)	Violet	Out	Fuel pump relay output	0.1A

3.3.2 Relay Board

The 'Relay Board' is an optional add-on that may be useful for installs that do not have any existing EFI wiring. It provides a 'main' relay to switch clean power to the Megasquirt, a 'fuel pump' relay to operate the pump and accessories and a 'fast idle' relay for an on/off type idle valve.

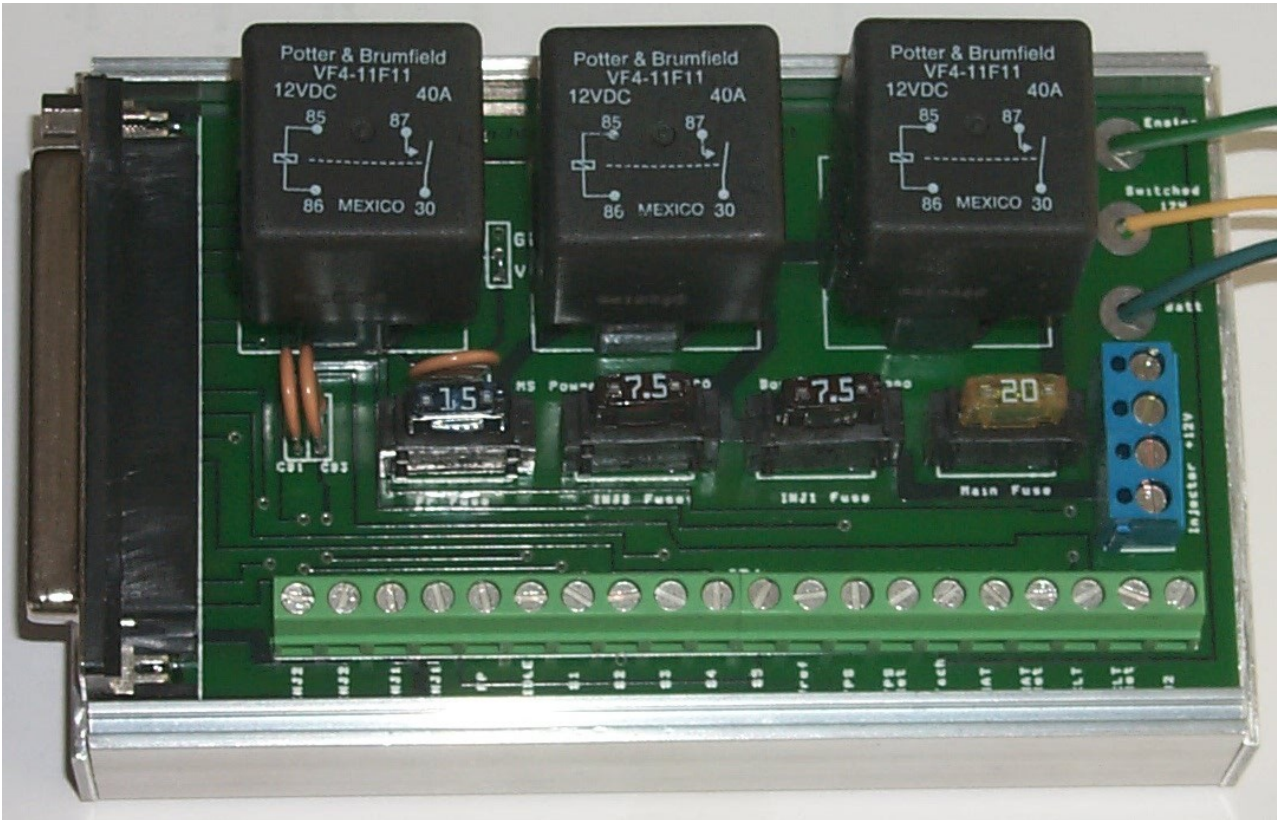

Not recommended for:

- sequential installs
- race installs
- low impedance injectors
- installs where the screw terminals connections may get wet.

Main plug to Relay board cross reference

DB37 #	DB37 Name	Relay Board #	Relay Board Name	In/Out	Function	Max amps
1-2	GND	-	Engine GND	GND	POWER GROUND	-
3	SPR1	N/A	Not available*	(Comms)	(CANH)	-
4	SPR2	N/A	Not available*	(Comms)	(CANL)	-
5	SPR3	N/A	Not available*	-	spare	-
6	SPR4	N/A	Not available*	-	spare	-
7-18	GND	-	Engine GND	GND	POWER GROUND	-
19	GND	14	TPS Ret	GND	Sensor GND	-

19	GND	17	MAT Ret	GND	Sensor GND	
19	GND	19	CLT Ret	GND	Sensor GND	
20	MAT	16	Air Temp	In	MAT sensor input	-
21	CLT	18	Coolant	In	CLT sensor input	-
22	TPS	13	TPS	In	TP Sensor input	-
23	O2	20	O2	In	Oxygen/lambda sensor in	-
24	TACH IN	15	Tach/Ignition	In	'Crank' Tach input	-
25	IAC1A	7	S1	(Out)	(IAC1A)	0.5A
26	TPSVREF 5V	12	VREF	Out	5V supply for TPS	0.1A
27	IAC1B	8	S2	(Out)	(IAC1B)	0.5A
28	+12V In	-	-	In	From main relay	
29	IAC2A	9	S3	(Out)	(IAC2A)	0.5A
30	FIDLE	(6)	-	Out	Via idle relay	
31	IAC2B	10	S4	(Out)	(IAC2B)	0.5A
32	INJ1	3 + 4	INJ1	Out	Injector bank 1 output	7A
33	INJ1	3 + 4	INJ1	Out	Injector bank 1 output	7A
34	INJ2	1 + 2	INJ2	Out	Injector bank 2 output	7A
35	INJ2	1 + 2	INJ2	Out	Injector bank 2 output	7A
36	IGN	11	S5	(Out)	(High current ignition)	7A
37	FP (Pump)	(5)	-	Out	Via fuel pump relay	

Relay Outputs

The FIDLE and FP ground outputs from the Megasquirt are used to control relays on the relay board.

Relay Board #	Relay Board Name	In/Out	Function	Max amps
6	FIDLE	RELAY OUT	On/off idle valve	3A
5	FP	RELAY OUT	Fuel pump relay	15A

Notes:

1. SPR1,2,3,4 connections from the mainboard are not available on the relay board. You will need to cut into the relay board cable and break these connections out.
2. INJ1, 2 power feeds have 7.5A fuses. These are intended for batchfire injectors only.
3. The 'FIDLE' output is hardwired to a relay. This is jumper selectable using to provide a 12V ("V") output or a ground ("G") output. Do not used for very high current devices. This could be used to operate a secondary fan relay.

4. When using a PWM idle valve from the 'FIDLE' output, the idle relay must be left out and bypassed.

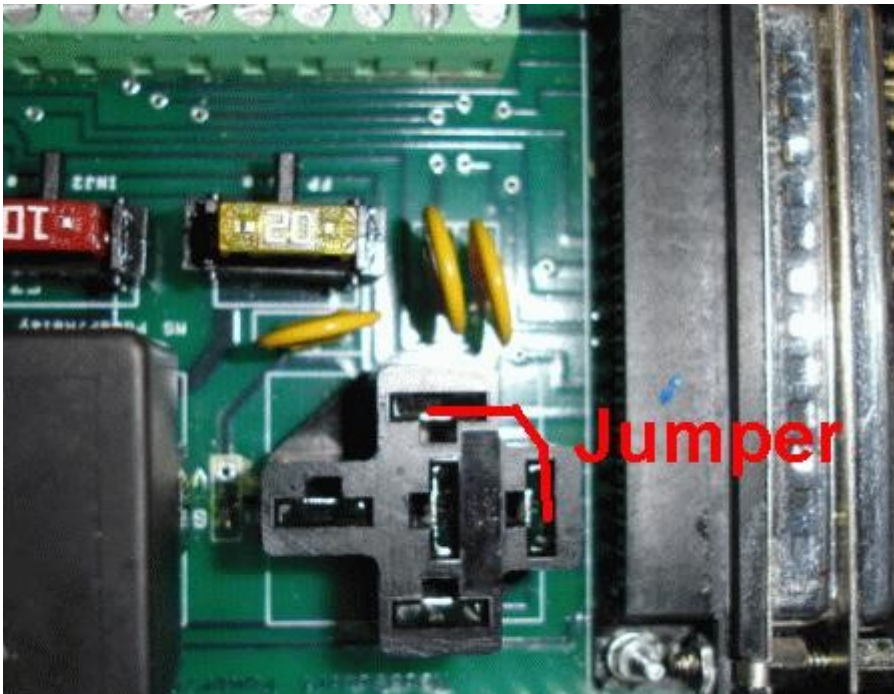

3.4 Inputs

3.4.1 Crank and Cam Tach inputs



These sensors provide the Megasquirt with engine position information and are used to schedule fuel and spark. See chapter 5 for more information.

3.4.2 MAP (Manifold Absolute Pressure) sensor

The MS2/V3.0 uses an internal MAP sensor.

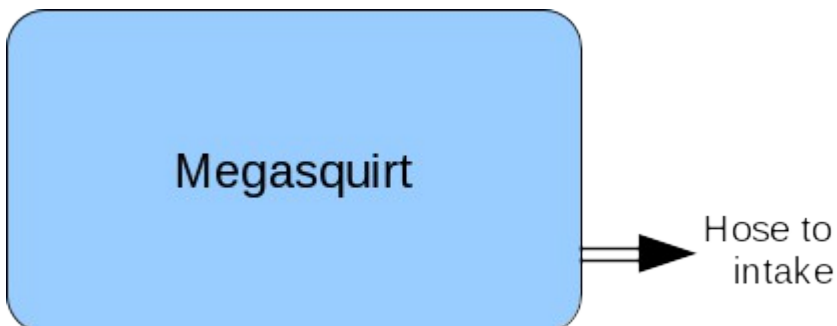

This sensor measures air pressure on absolute scale where zero is a complete vacuum and sea-level ambient pressure is around 101kPa. This sensor is the primary input for the "Speed-Density" fuel algorithm. Alpha-N users do not require a MAP sensor and can optionally use the built-in sensor as a baro sensor.

The pressure barb is connected to a full-vacuum source at the intake manifold. When tapping into any existing vacuum ports on a throttle body be sure to select one that gives full vacuum when the throttle is closed. (i.e. not a "ported vacuum" source that would connect to a distributor.)

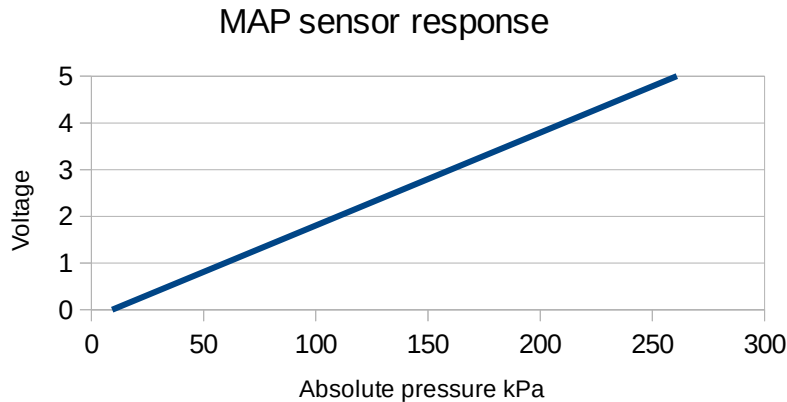

Optionally a second sensor may be installed to measure barometric pressure. This works in the same way but typically a 1-bar sensor is used. The pressure feed port is left open to the atmosphere and will help the engine respond to changes in ambient pressure or elevation.

3.4.3 IAT/MAT (Intake/Manifold Air Temperature) sensor



This external sensor measures the temperature of the air entering the engine. This is used to calculate air density and is a key factor in the Speed-Density fuel calculation.

The temperature sensor is a variable resistor (a thermistor). Higher temperatures give a lower resistance, the response is non-linear.

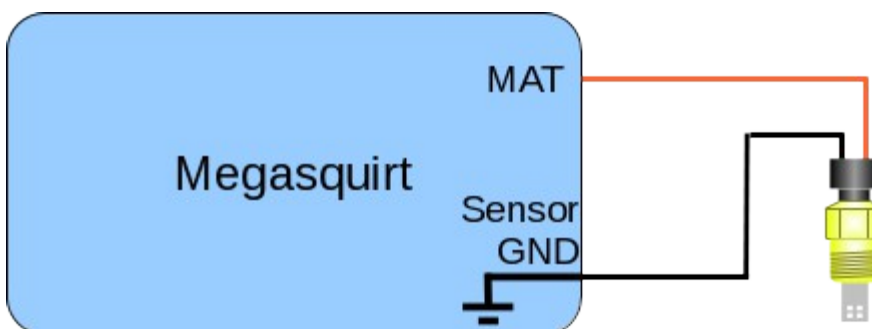

Any install not using a MAT should connect the MAT input to sensor ground to prevent the reading "floating".

A good sensor will have two wires, one wire connects to sensor ground, the other to the MAT input on the ECU.

One-wire sensors are not recommended.

The sensor may either be an "open-element" or "closed-element" type sensor. "Open-element" sensor have a thermistor directly exposed to the air-stream - this type of sensor is required for turbo-charged application where the air temperature can change quickly. The "closed-element" type sensor is identical to a coolant temperature sensor and has an encapsulated thermistor - these respond too slowly for turbo-charged application.

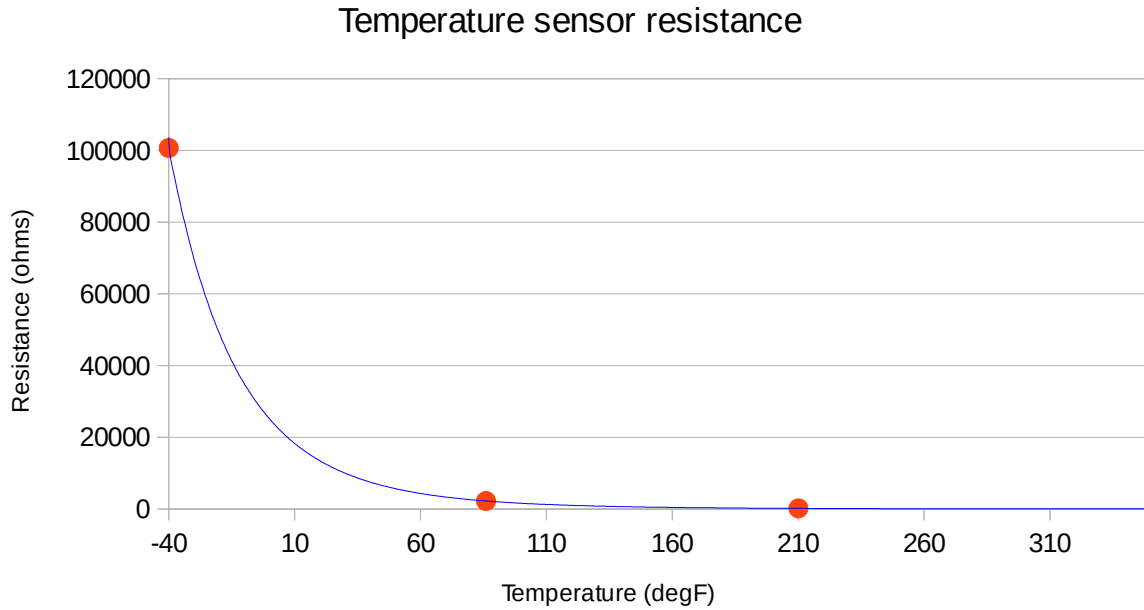

The red dots are the three standard calibration points for GM sensors.

The ECU uses a circuit to convert the resistance into a voltage that it measures.

Temperature sensor signal at ECU

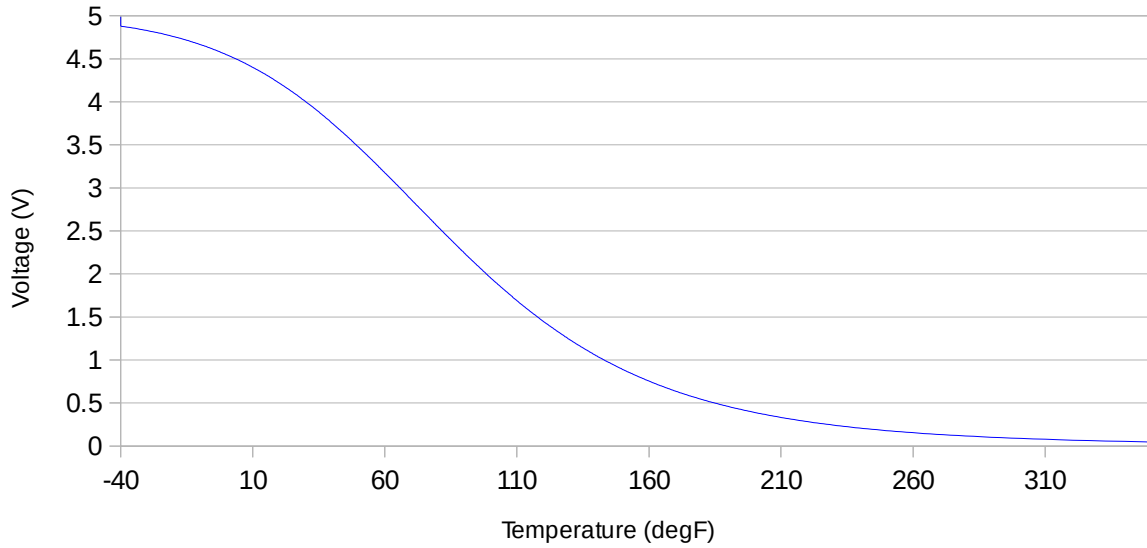

3.4.3.1 Sensor calibration

TunerStudio includes many predefined calibration curves to select from, but for other "unknown" sensors the three calibration points can be determined.

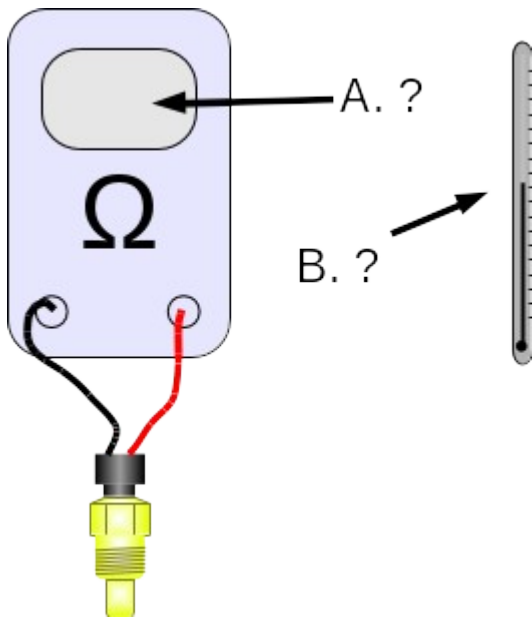

The manual calibration process requires the use of a multimeter set to measure resistance and ideally a thermometer. Without a thermometer your calibration will be fairly close but not perfect.

1. Set the meter to ohms and connect the meter to the two terminals on the MAT or CLT sensor.
2. Allow the sensor to reach room temperature.
3. Take the resistance reading.
4. Measure room temperature using a thermometer (typically 20°C / 68°F)
5. Place the end of the sensor in a mixture of ice melting in water and allow it to stabilize.
6. Take the resistance reading.
7. Measure the ice/water temperature using a thermometer (typically 0°C / 32°F)
8. Place the end of the sensor in a pan of boiling water and allow it to stabilize.
9. Take the resistance reading.
10. Measure the boiling water temperature using a thermometer (typically 100°C / 212°F)

You now have the three calibration points for TunerStudio.

For a GM sensors these should be close to:

Where	°C	°F	Ohms
Ice/water	0	32	9441
Room temp.	20	68	3518
Boiling water	100	212	172

Note that the default calibration data in TunerStudio goes down to -40° but that's rather difficult to measure in the normal workshop.

3.4.4 CLT (Coolant Temperature) sensor



This external sensor measures the temperature of the engine coolant (or cylinder head for air-cooled engines.) It is primarily used to provide additional fuel during engine warm-up.

The coolant temperature is a thermistor and works in the same way as the air temperature sensor.

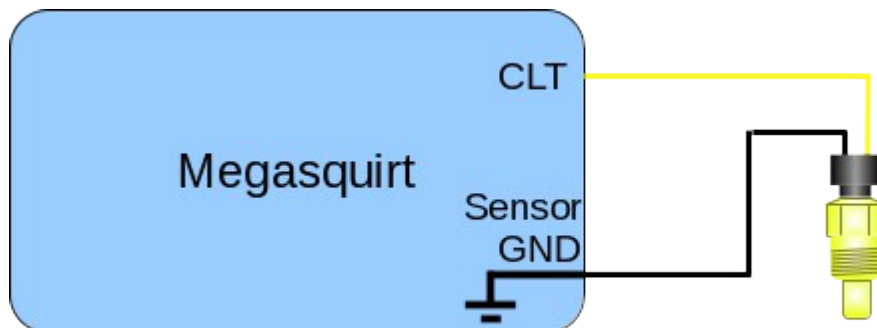

Any install not using a CLT should connect the CLT input to sensor ground to prevent the reading "floating".

A good sensor will have two wires, one wire connects to sensor ground, the other to the CLT input on the ECU. One-wire sensors are not recommended.

3.4.5 TPS (Throttle Position Sensor)

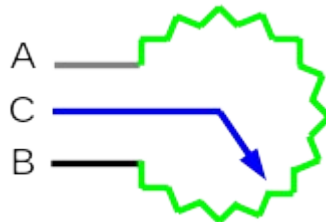
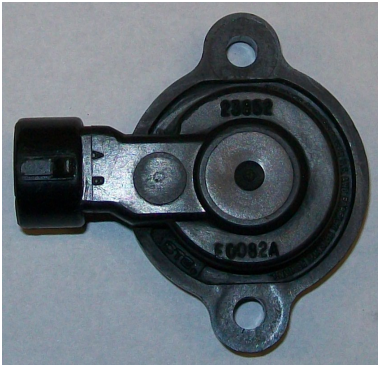

This external sensor measures the position of the throttle plate. It is a variable resistor (potentiometer) and sends a 0-5V signal back to the Megasquirt. The sensor has three wires, 5V supply (TPSVREF), Ground (sensor ground return) and signal. The Megasquirt converts the signal to a 0-100% scale using your calibration numbers. 0% corresponds to fully closed, 100% to fully open.

Switch-type throttle position sensors are not recommended.

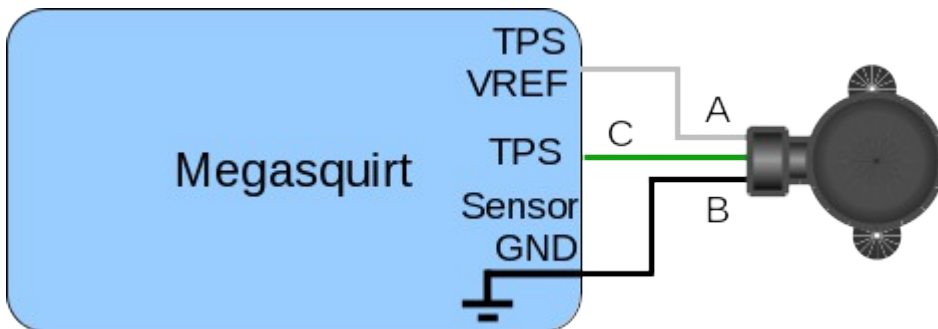

Any install not using a TPS should connect the TPS input to sensor ground to prevent the reading "floating".

3.4.6 O2 (Oxygen) Sensor / Lambda Sensor



1-wire Narrowband



4-wire Narrowband



Wideband

The O₂ / oxygen sensor / lambda sensor input gives feedback on the air:fuel ratio (mixture) of the engine and is screwed into a threaded bung which is welded into the exhaust system. Ensure that there are no air leaks or the readings will be inaccurate.

Narrowband sensors are cheap and very accurate for reading "stoichiometric" mixtures (e.g. 14.7 AFR or 1.000 lambda.) They are widely used by OEMs where the 3-way catalysts require these mixtures for correct operation. They do not give accurate readings under rich or lean conditions.

1-wire narrowband sensors rely on exhaust heat to bring them up to operating temperature and are typically mounted close to the exhaust ports or the "collector" of a cast exhaust manifold.

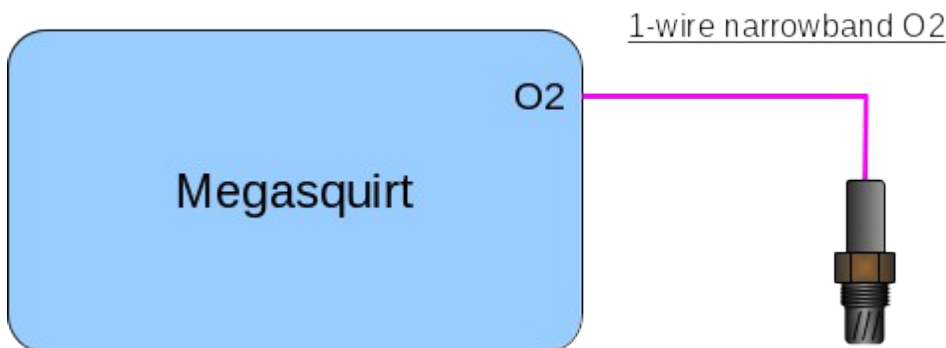

4-wire narrowband sensors include a heater and a signal ground. These can be mounted further away from the exhaust port as they are self heating. Preferable to a 1-wire.

Typical wiring

Blacks = heater power and ground

Blue = signal ground

White = O₂ signal

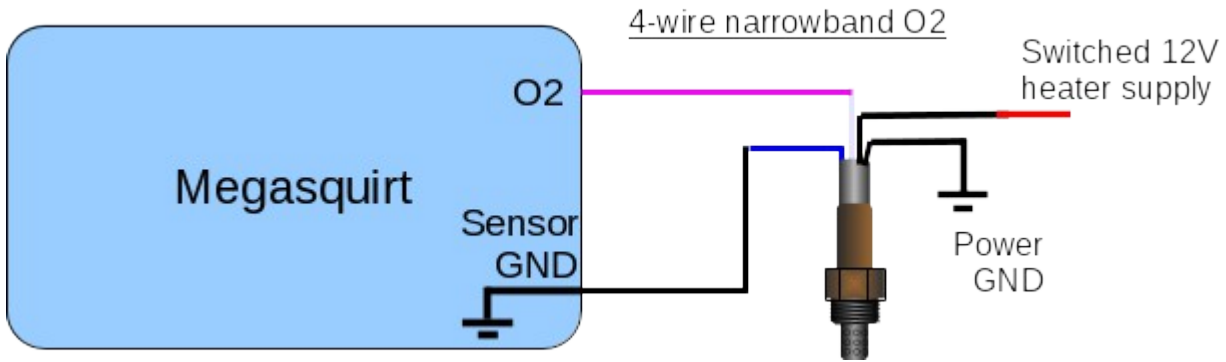

Wideband sensors require an external controller for use with the Megasquirt. Widebands are more expensive than narrowband sensors but give readings over a far wider range of exhaust mixtures. When used with a Megasquirt they give you the ability to tune your engine in the rich (power) and lean (cruise) regions. Strongly recommended.

The better controllers offer a signal ground which should be connected to the Megasquirt sensor ground. Other models require grounding to the engine block only. Consult the directions that came with your wideband controller.

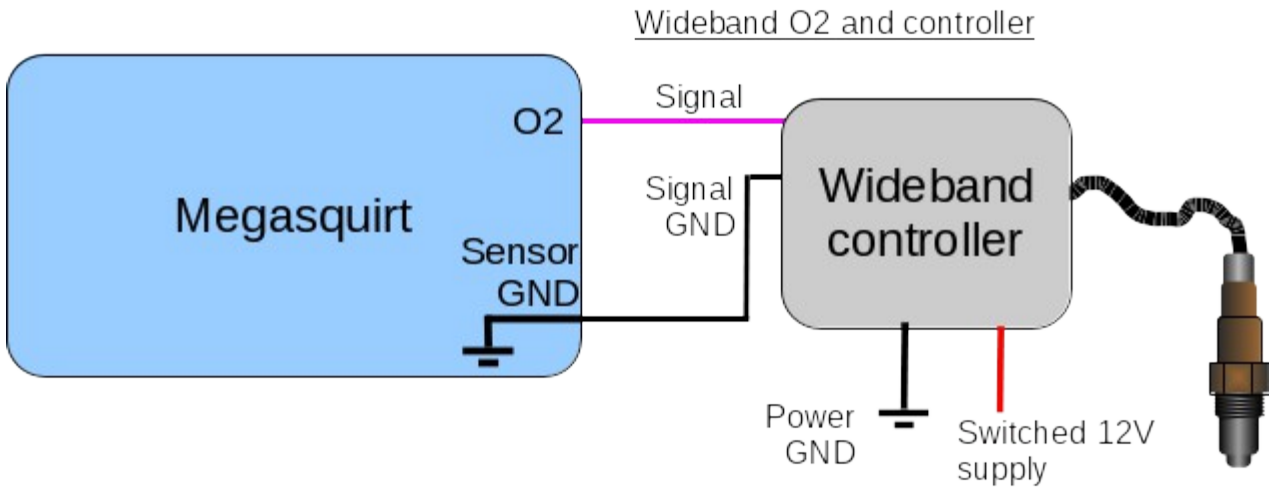

3.4.7 MAF (Mass Air Flow) Sensor



Ford Lightning 6 pin MAF



Nissan Infiniti Q45 MAF

The MAF Sensor measures the actual mass air-flow into the engine. This can be used for a more accurate fueling calculation- other fueling algorithms estimate the mass air flow based on MAP, TPS, RPM, MAT.

MS2/Extra supports voltage MAFs only. Frequency MAFs (such as LS1) are not supported.

The sensors have at least three wires, 12V supply, Ground (sensor ground return) and signal to the Megasquirt.

To connect a MAF to MS2/V3.0 internal hardware modifications are required. You may choose from either pin 'JS5 (ADC6)' or 'JS4 (ADC7)' so long as the input port setting in TunerStudio is set to match.

Externally you choose which pin on the main connector is used. Typically SPR3 or SPR4 would be used if they are free.

Parts required. 1k 1/8W (or 1/4W) resistor. 0.22u 10V ceramic capacitor.

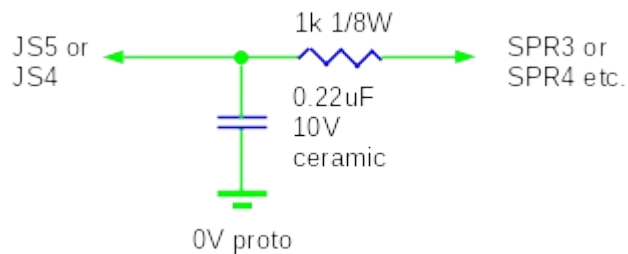

Solder into proto area. Run jumper wire to JS5 or JS4 (your choice.) Run jumper wire to SPR3 or SPR4 (your choice.)

Ford 4 pin MAF

This earlier style MAF has an oval connector.

A = Switched 12 volts supply

B = Power Ground

C = MAF signal ground

D = MAF output signal

Ford - 4 wire MAF

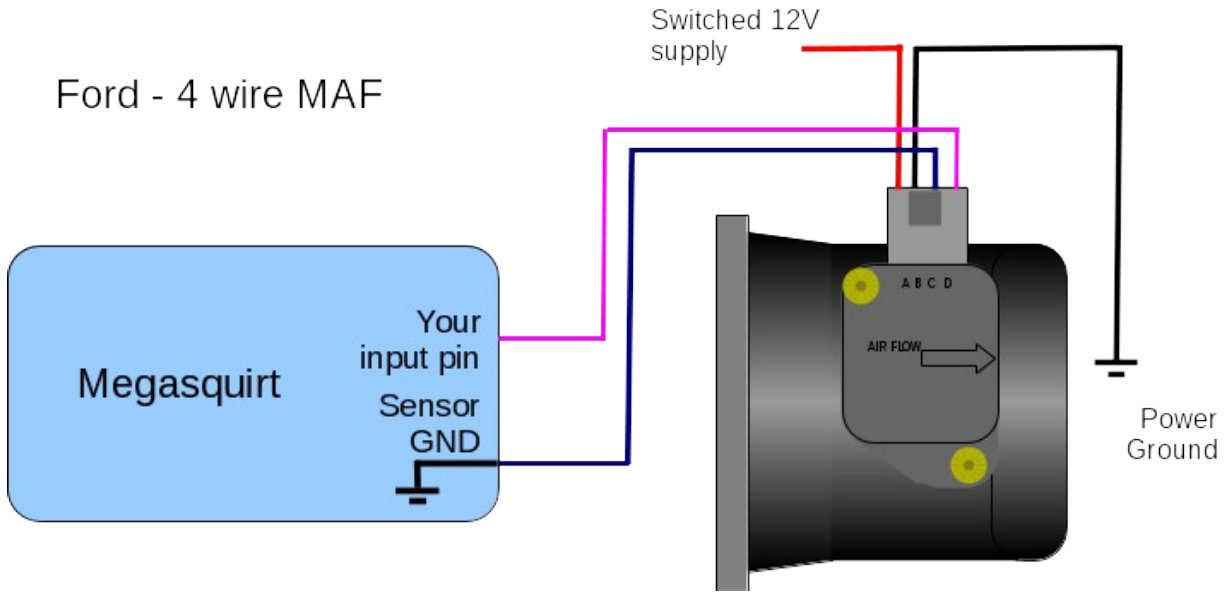

Ford 6 pin MAF

This MAF also includes an intake air temperature sensor, so an additional MAT is not required.

- E = IAT sensor signal ground
- A = Switched 12 volts supply
- B = Power Ground
- C = MAF signal ground
- D = MAF output signal
- F = IAT sensor signal

Ford - 6 wire MAF

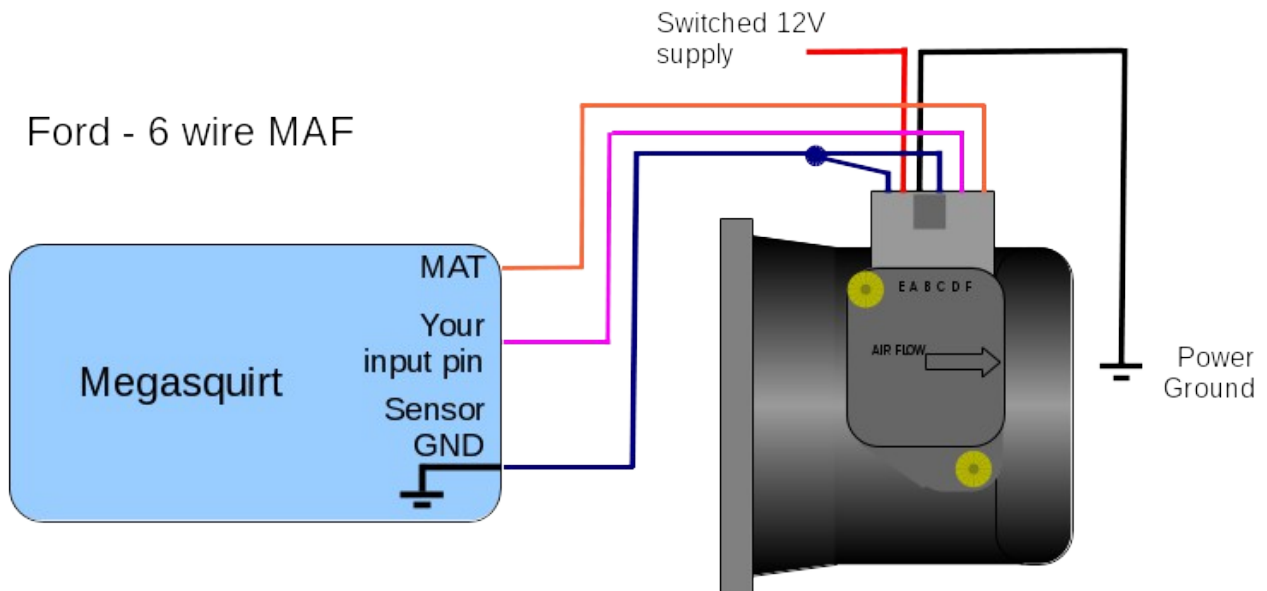

Nissan Infiniti Q45 90mm MAF

B = MAF output signal (White)

D = Ground (Black)

E = Switched 12 volts (Black/white)

Nissan Q45 3-wire MAF

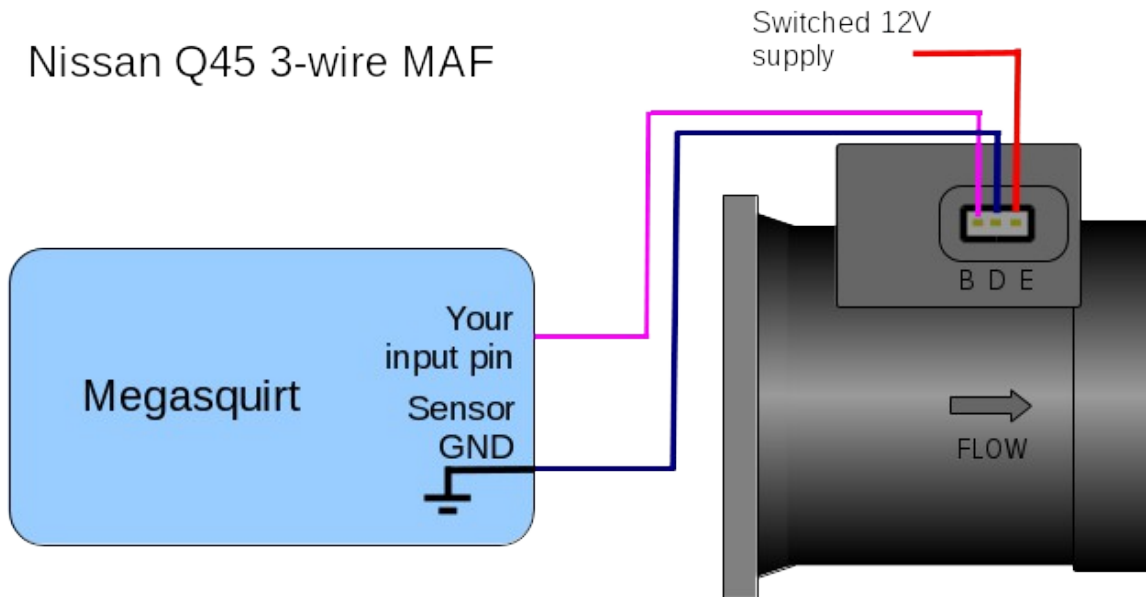

The flow response of MAF sensors is non-linear and uses a calibration tuning curve in the Megasquirt to convert the input signal into a grammes/second flow rate number.

MAF sensor response (Ford V8)

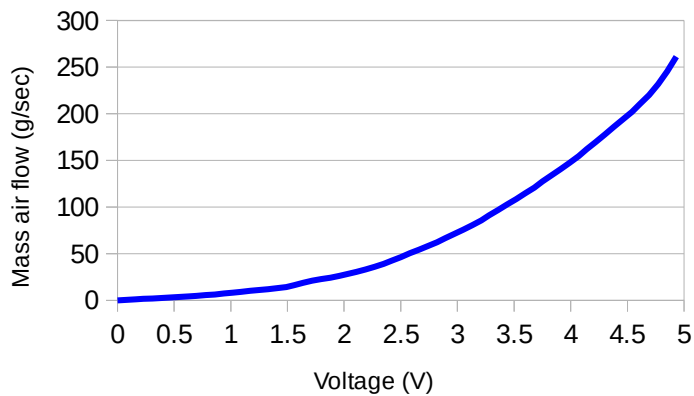

3.4.8 Flex / Switch input



The Flex fuel (or fuel composition) sensor detects the percentage of ethanol within the fuel passing through it. This can be used by the Megasquirt to automatically adjust fuel and spark to allow for the change in fuel. Higher ethanol blends require more pulsewidth and additional spark advance.

The GM sensor (shown) uses barbed pipes, the Ford sensor uses screw in fittings.

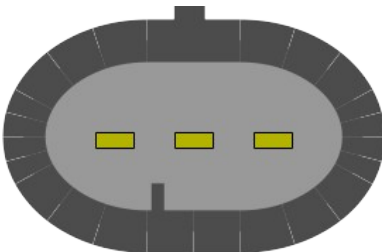

GND 12V Signal

Looking into sensor connector from left.

Ground (GM = white, Ford = Black)

+12 Volt supply (GM/Ford = pink)

Output signal, (GM = purple, Ford = white)

GM and Ford appear to use the same sensor but the letters on the connector may be different.

To connect a Flex Fuel sensor to MS2/V3.0 internal hardware modifications are required. You may choose from either pin 'PE0/JS7' or 'JS11' so long as the input port setting in TunerStudio is set to match.

Externally you choose which pin on the main connector is used. Typically SPR3 or SPR4 would be used if they are free.

Parts required. Two 10k 1/8W (or 1/4W) resistors.

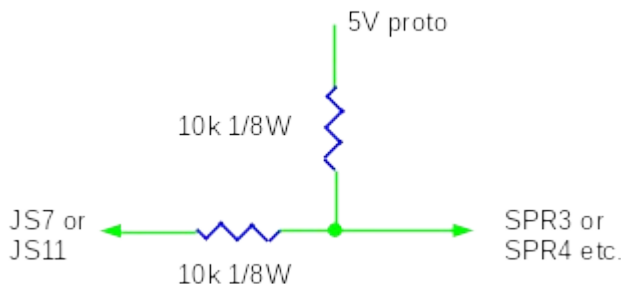

Solder into proto area. Run jumper wire to JS7 or JS11 (your choice.) Run jumper wire to SPR3 or SPR4 (your choice.)

Using JS7 requires that a jumper wire also be installed on the MS2 card itself. (Green wire.)

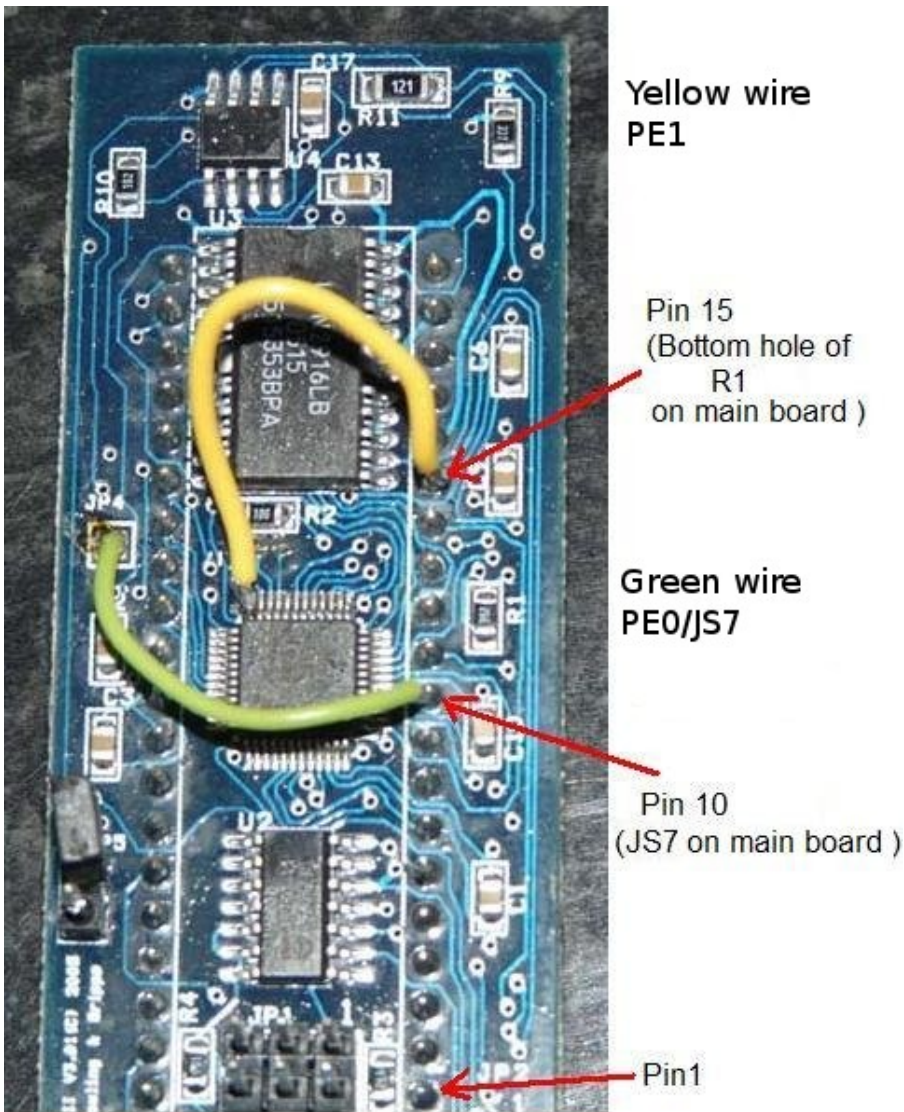

Exercise caution when soldering to the MS2 card. Ensure there are no solder bridges on the processor.

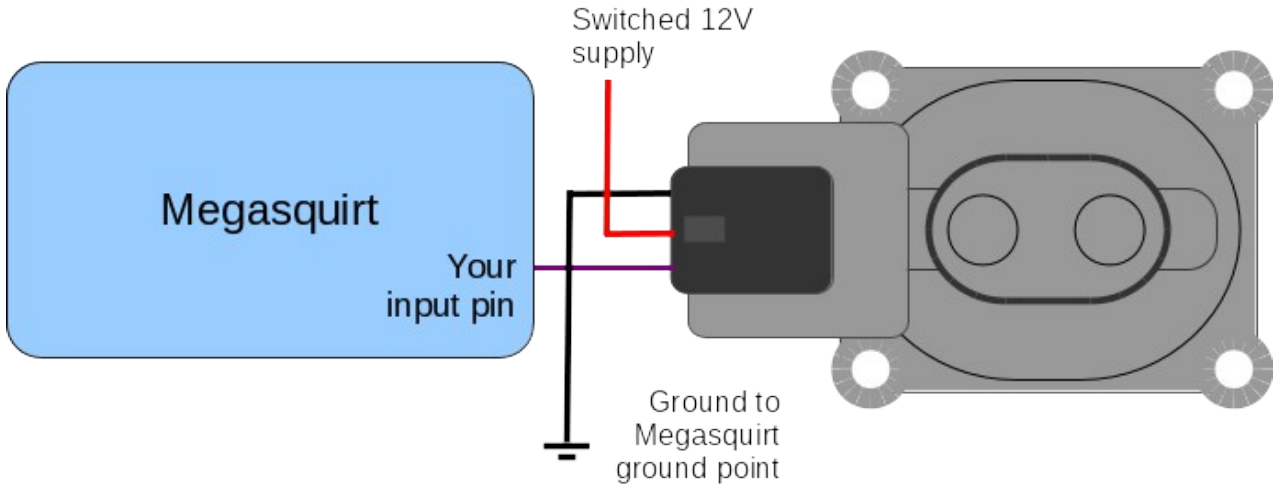

3.4.9 Spare ADCs / Switch inputs

3.4.9.1 Analogue inputs

The JS4, JS5 connections on the MS2 card can be used as 0-5V analogue inputs.

Parts required. One 1k 1/8W (or 1/4W) resistor, one 0.22uF 10V ceramic capacitor.

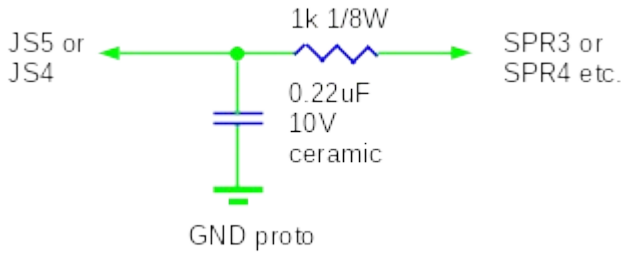

Solder into proto area. Run jumper wire to JS4 or JS5 (your choice.) Run jumper wire to SPR3 or SPR4 (your choice.)

Analogue options: MAF, 2nd O2 sensor, Baro sensor, misc sensor.

Input pin name	Processor (DIP40) pin number	Note
JS4/AD7	30	Analogue input or digital input
JS5/AD6	29	Analogue input or digital input

When used for a misc analogue sensor input, JS5 is datalogged as ADC6 on a scale of 0-1023 points and JS4 is datalogged as ADC7. See the TunerStudio manual for more detail.

3.4.9.2 Switch inputs

Switch input options: Launch input, nitrous input, shift cut input.

These features all require a ground at the MS2 card to activate the feature. All require internal hardware modifications.

The simpler modification is for a ground switched input. (Recommended.)

A 12V switch input requires more components.

As with other inputs, you choose which MS2 pin to use and which main connector pin to use.

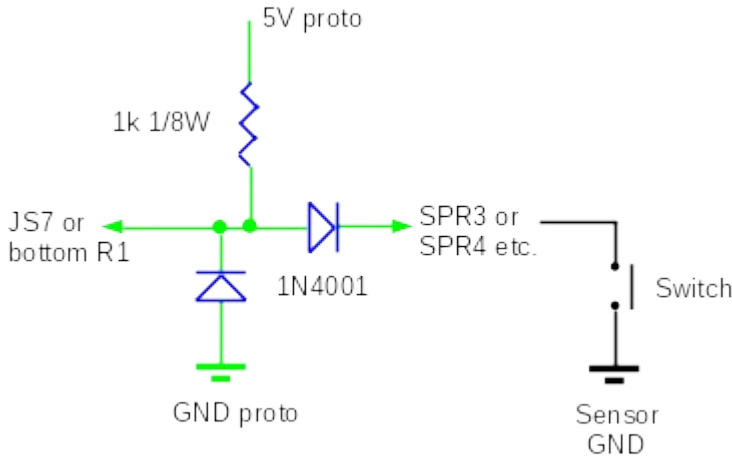

Ground switch input

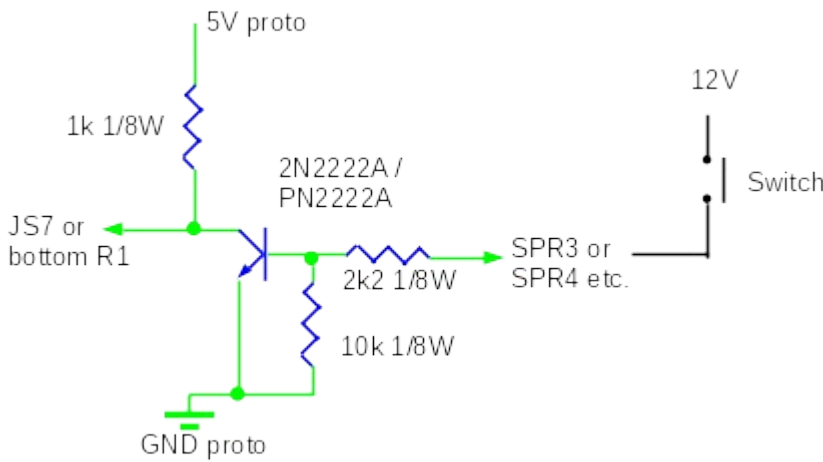

12V switch input

Input pin name	Processor (DIP40) pin number	Note
JS4/AD7	30	Analogue input or digital input/output.
JS5/AD6	29	Analogue input or digital input/output.
JS10	17	Digital input/output
JS11	18	Digital input/output
JS7/PE0	10*	Digital input only (needs mod.)
PE1	15*	Digital input only (needs mod.)

*MS2 card modification required.

Using JS7/PE0 requires that a jumper wire also be installed on the MS2 card itself. (Green wire.) Using PE1 requires that a jumper wire also be installed on the MS2 card itself. (Yellow wire.)

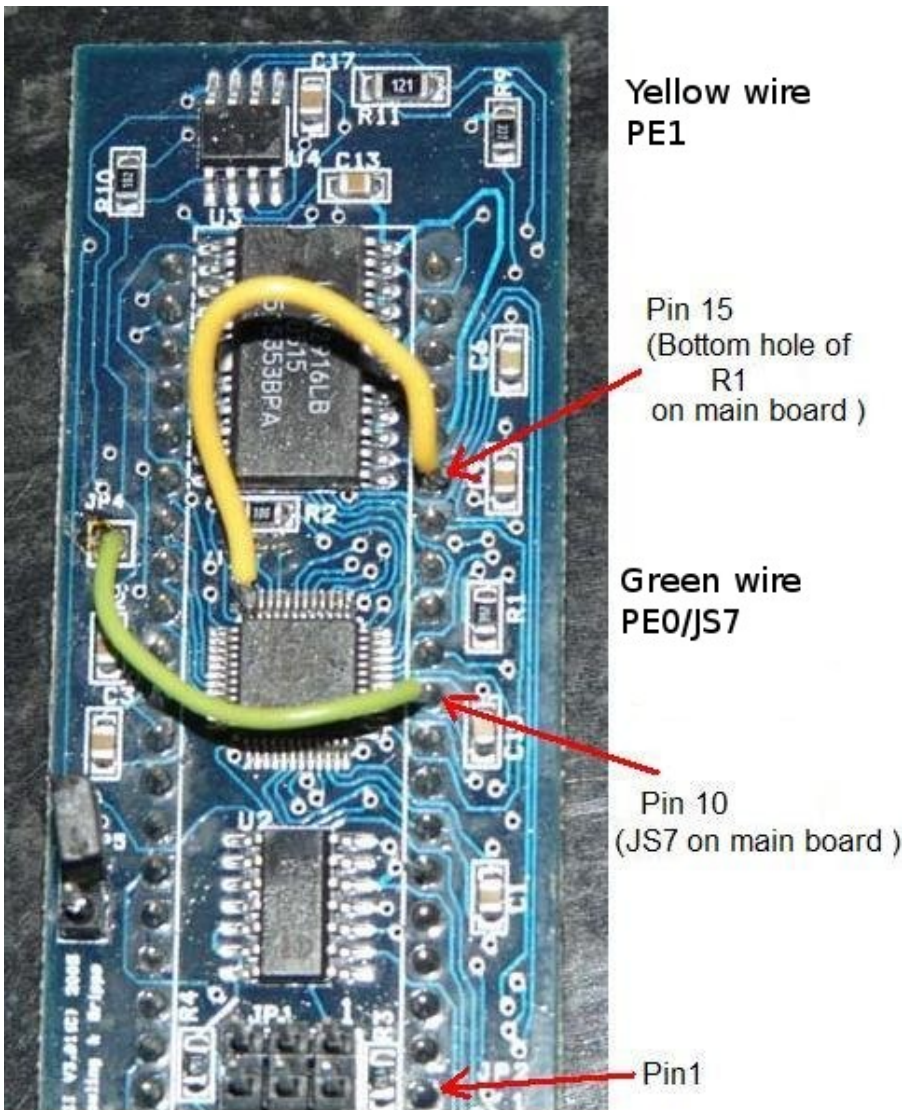

Exercise extra caution when soldering the yellow wire to the MS2 card - a fine wire and fine soldering iron tip are needed.

Not recommended for novices.

See the specific feature for information on how to configure the inputs.

3.4.10 B/LD boot jumper

The B/LD jumper on the MS2 card is shorted (with a shunt) to force the Megasquirt into "bootloader" monitor mode. This is only typically needed when loading the firmware for the first time. It can optionally be used if the firmware has become corrupted (e.g. an ignition spike got into the wiring harness) and the normal firmware loading will not function.

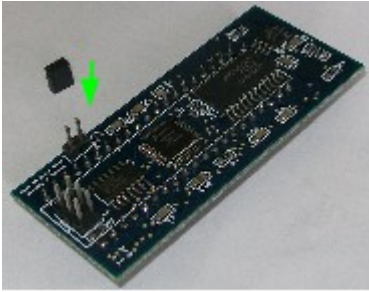

3.4.11 CAN comms

The CANH/L wires are used to connect to add-on units such as transmission control, CANEGT interfaces, data capture or compatible dashboards.

The Megasquirt includes a terminating resistor.

To use the CAN connections, you need to run internal jumper wires:

JS6 -> SPR1 = CANH

JS8 -> SPR2 = CANL

In general, CAN forms a bus network with a 120R terminator at each end and devices wired as short 'drops' off the network.

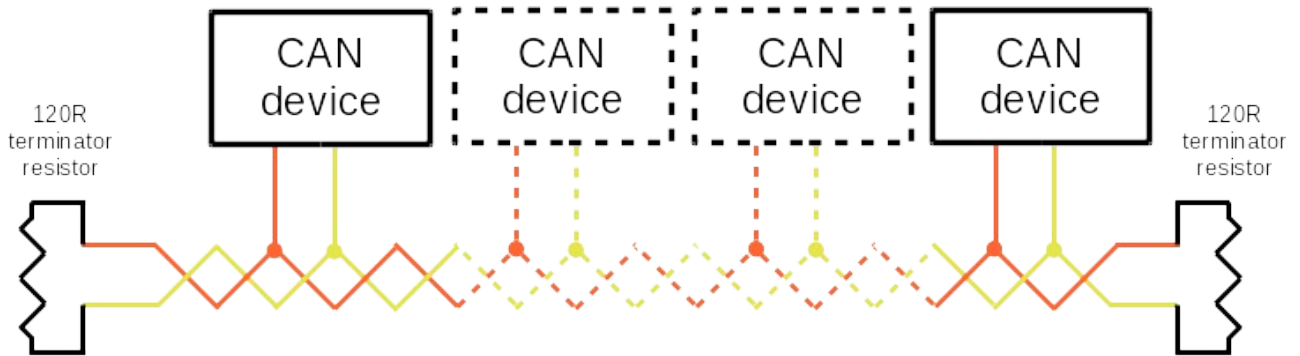

The Megasquirt includes a terminating resistor internally, so no additional resistor is required at that end.

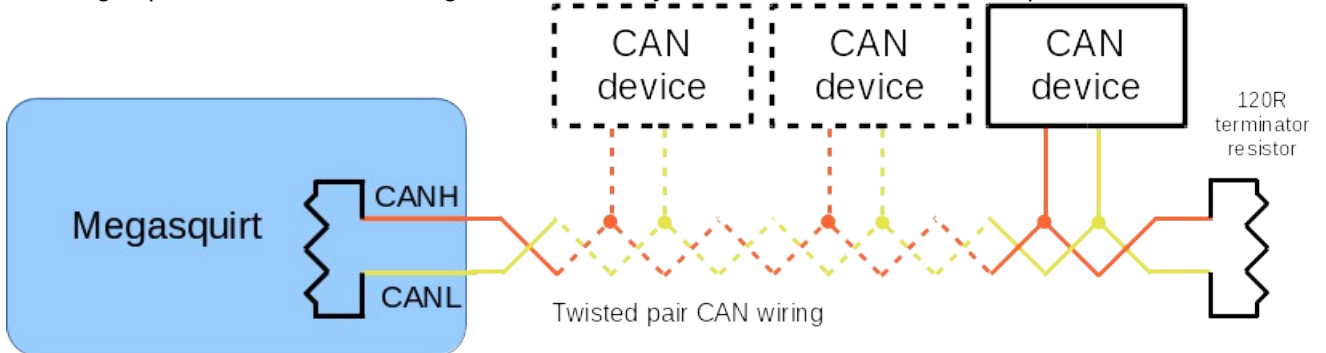

3.4.12 Knock sensor

Megasquirt supports knock sensing with an external interface to the knock sensor. Do not connect a sensor directly to the Megasquirt - it will not work.



Two configurations are available - on/off or analogue.

The **on/off mode** can be used with a GM ESC module (16022621, 16052401)

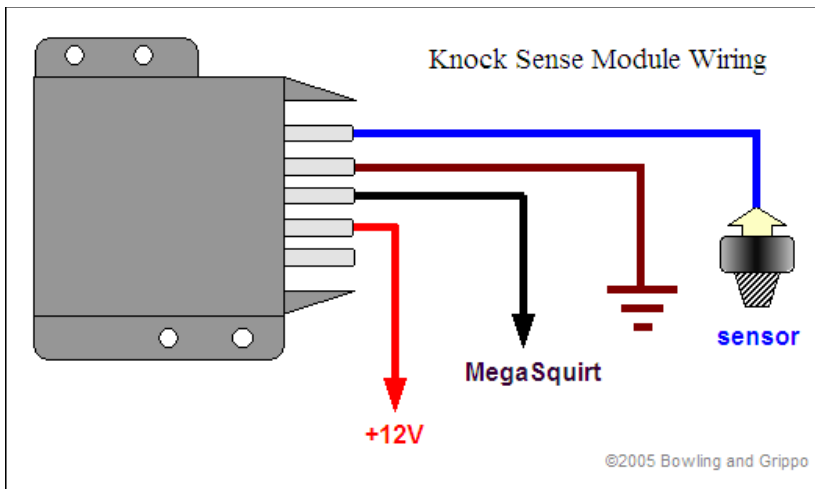

The connection to the Megasquirt is on JS4 or JS5.

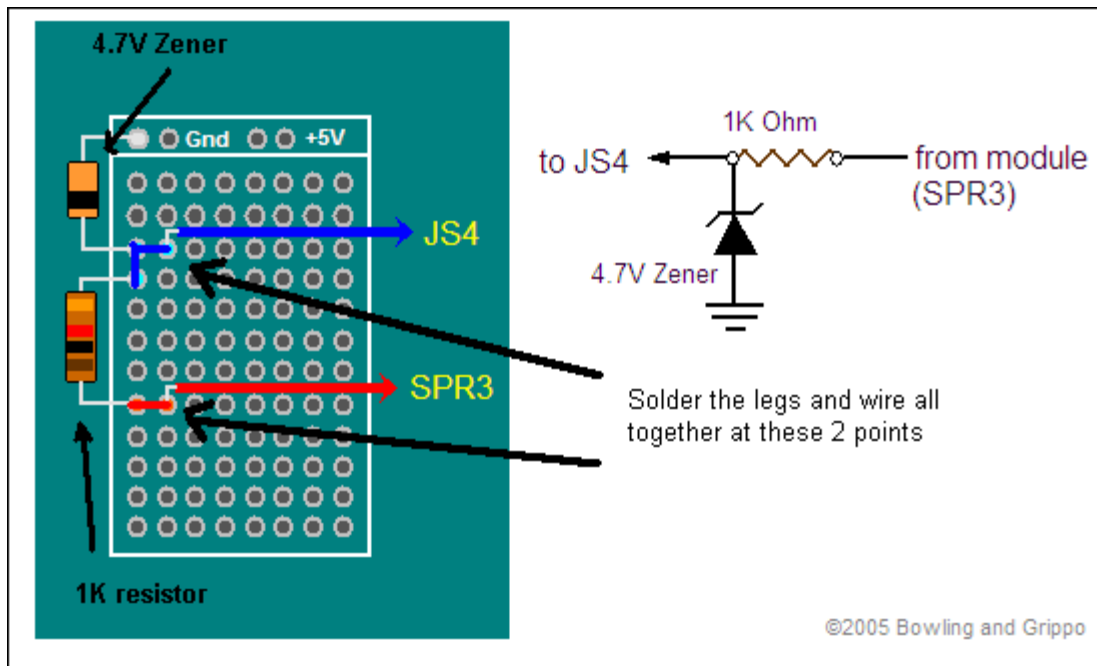

In the **analogue mode**, 0-5V signal is fed into JS4 or JS5 using a protective circuits as in 3.4.9.1.

3.5 Outputs

3.5.1 Fuel Injector outputs

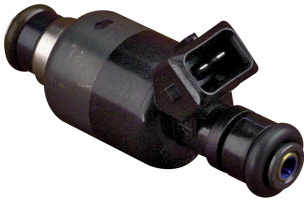

The Megasquirt has two injector outputs. These can supply up to 14A maximum each. Typically this allows up to six injectors per channel. MS2/V3.0 supports both hi-z (14 ohm) and low-z (e.g. 2.5 ohm) injectors directly.

Fuel injectors are covered in more detail in section 4.

3.5.2 Ignition outputs



The Megasquirt can provide up to six ignition outputs. All require some internal modifications.

Ignition outputs and the ignition system are covered in more detail in section 5.

3.5.3 Fuel pump output

The Fuel Pump output is low current low-side output used to drive a relay that switches the high current fuel pump. The coils and injectors should also take power from this relay so that when the engine is shutdown or stalls these are positively disconnected from power.

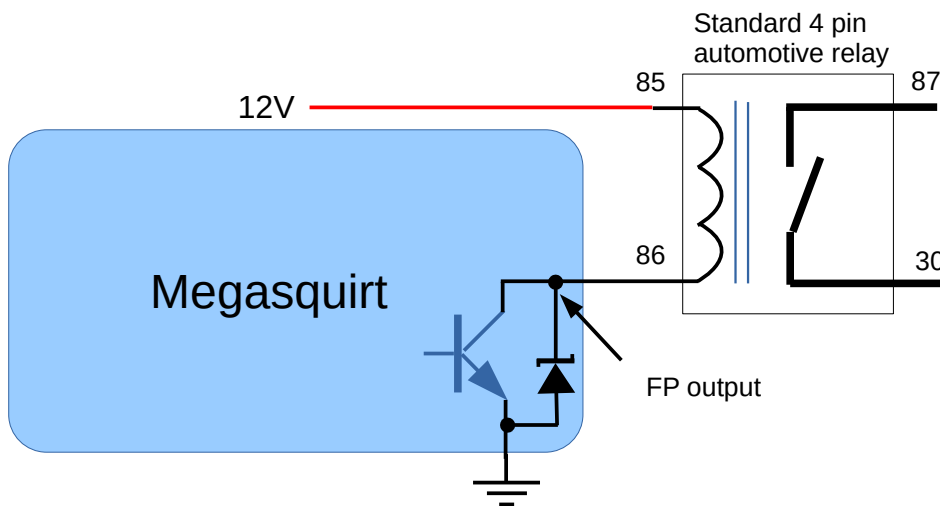

3.5.4 Idle valve

An idle valve is used to allow additional air into the engine, bypassing the throttle plate. This works similarly to the part of the choke mechanism on a carburettor and raises idle speed during warmup. Additionally it can be used for "closed-loop idle" to maintain a steady idle RPM under varying engine loads (lights on vs. off etc.)

As standard, the MS2/V3.0 supports on/off type valves and stepper idle motors. Servo type idle valves are not currently supported.

3.5.4.1 On/Off Idle Valve

The standard V3.0 circuit is used to operate a relay to drive the idle valve.

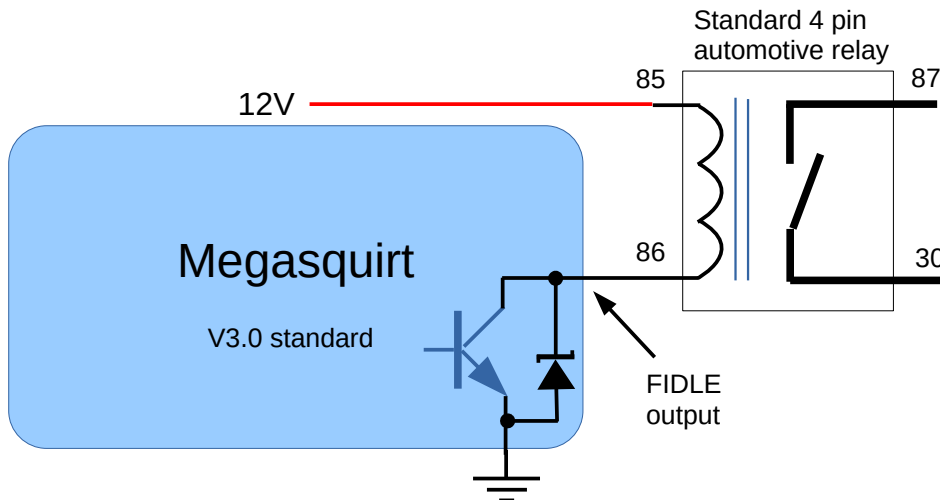

3.5.4.2 2-wire PWM idle valve

2-wire PWM idle valves are used by Ford, VW, Volvo and many others. The MS2/V3.0 requires an internal modification to be able to drive this type of valve.

Parts required:

TIP122

mica insulation kit

1N4001

- a) Remove Q4, Q20, D8 if fitted.
- b) Cut the legs of the TIP122 so they are half the length they were as new.
- c) Fit a piece of mica insulation under it and using plastic screws bolt it to the heatsink in a spare position, or bolt onto the case.
- d) Solder a wire from the center pin of Q4 to the pin 1 of the TIP122.
- e) Solder a wire from the right of R39 to the pin 3 of the TIP122
(Some installs might connect pin 3 to the bottom of R43, that's fine too.)
- f) Ensure D8 is not fitted or remove it if it is.
- g) Get an 1N4001 and install the non banded end into the right hole of D8 and the banded end to S12.
- h) Solder a wire from the non-banded side of the 1N4001 diode to pin 2 of the TIP122.

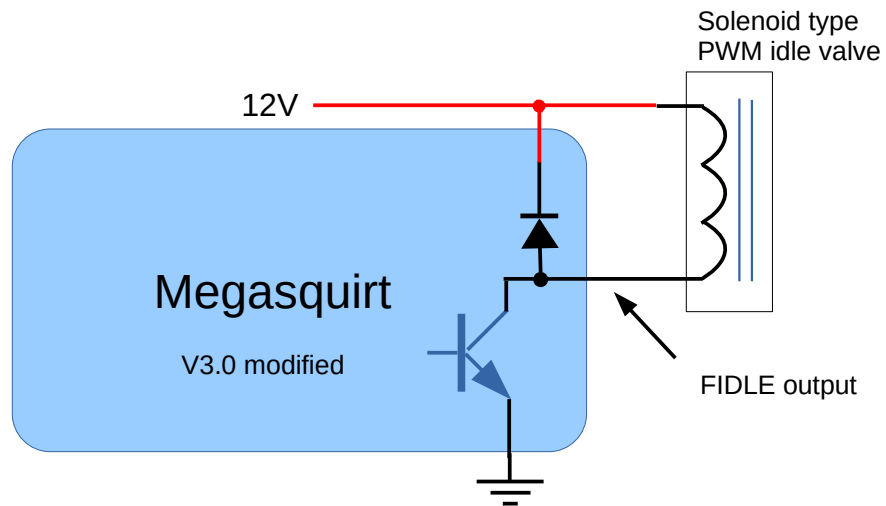
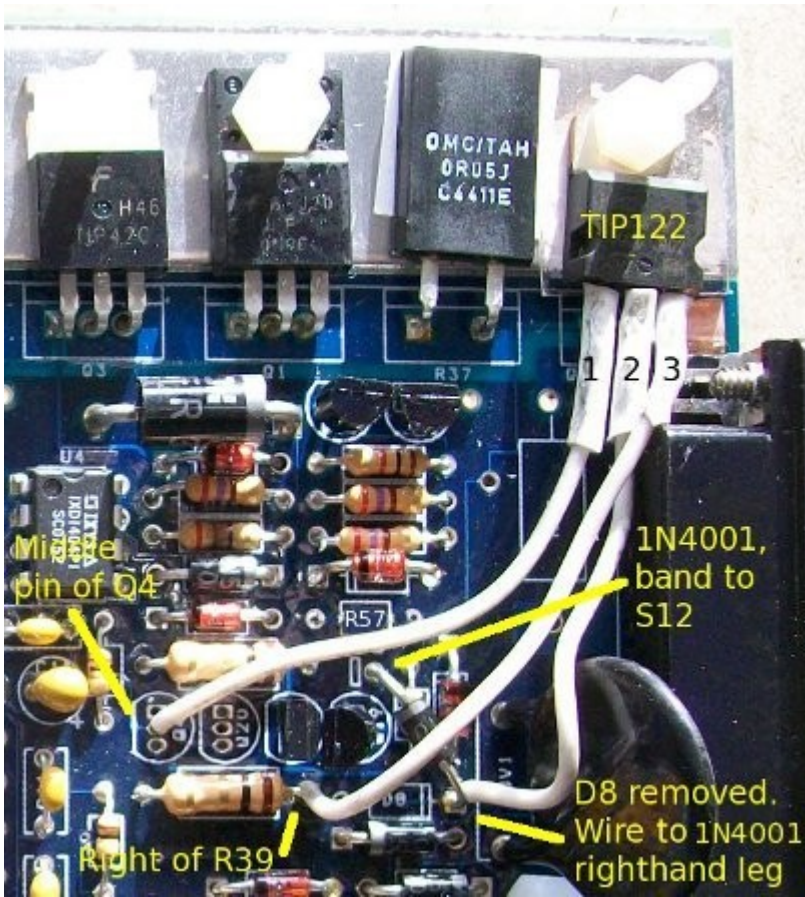

The 12V supply for the idle valve must be a fused switched supply - ideally from the fuel pump relay. It must never be supplied power when the Megasquirt is off.

3.5.4.3 4-wire or 6-wire stepper idle valve



4-wire stepper idle valves are common on many GM vehicles. MS2 can control these directly. All that is required is that internal jumper wires are installed

- a) JS0 to IAC1A
- b) JS1 to IAC1B
- c) JS2 to IAC2A
- d) JS3 to IAC2B
- e) JS9(+12V) to S12C

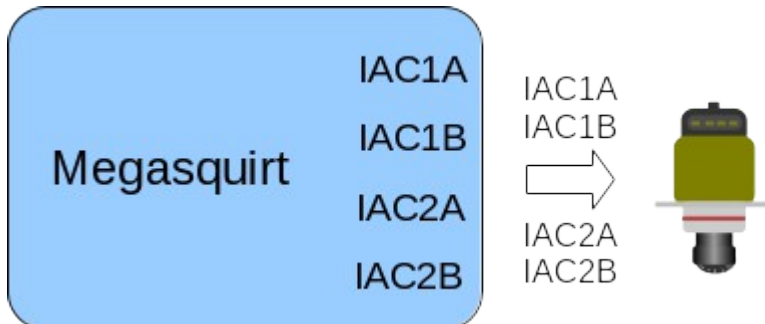

The 4-wire stepper motors commonly used by GM are "bi-polar" type.

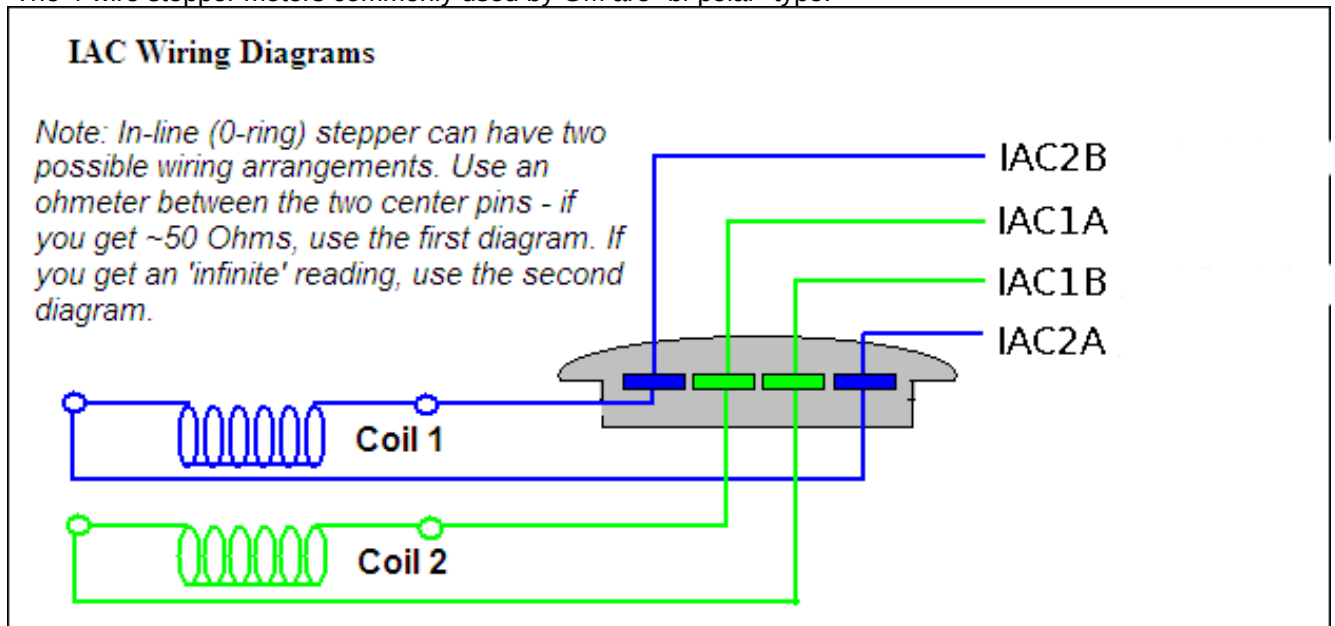

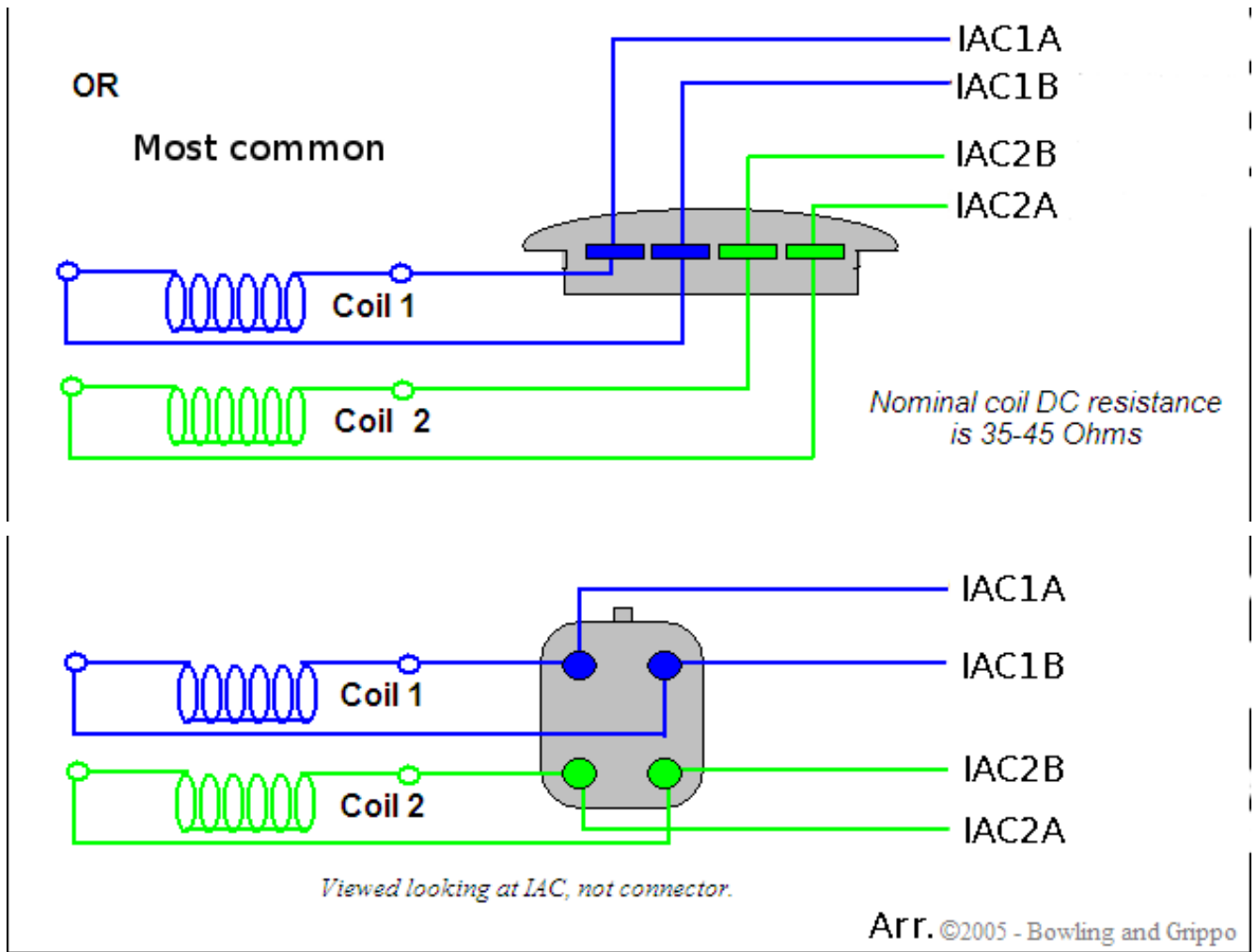

Other manufacturers use 5- or 6-wire steppers which are uni-polar.

These are usually wired as shown in the schematic below, with a center tap on each of two windings. In use, the center taps of the windings are typically wired to the 12V supply, and the two ends of each winding are alternately grounded to reverse the direction of the field provided by that winding.

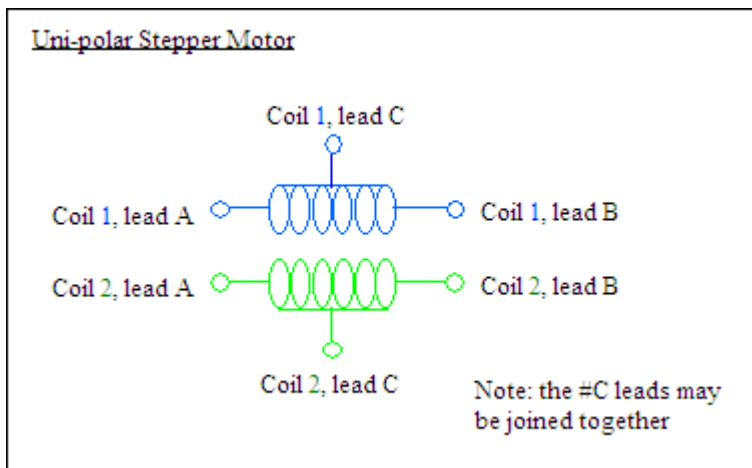

3.5.5 Tacho output

A tacho output typically provides a 0-12V pulsed signal that is suitable for driving an aftermarket tachometer (rev counter.)

Some older tachometers expect the high-current "spike" from the ignition coil and may not work directly with a 0-12V signal.

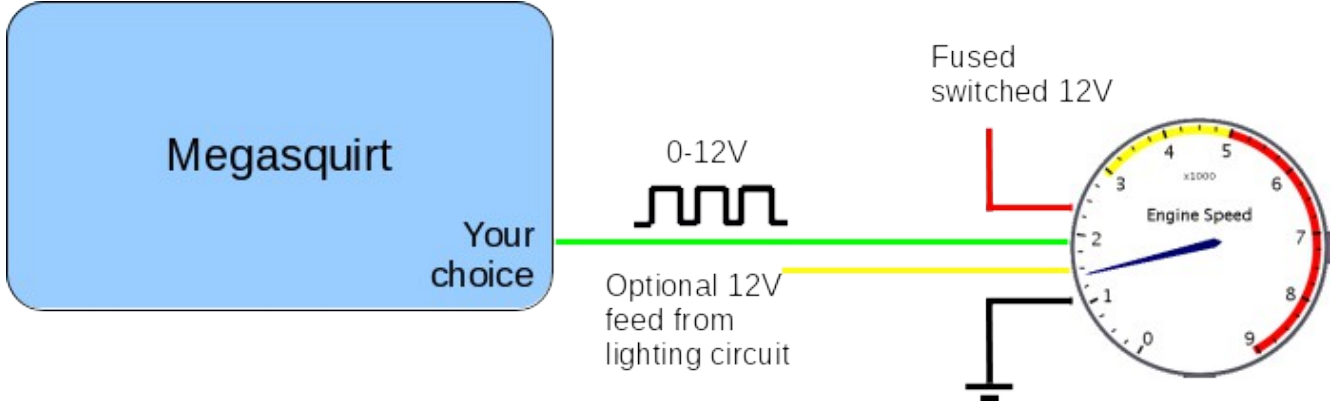

Outputs IAC1A, IAC1B, IAC2A, IAC2B provide a 0-12V signal. If these are not used for a stepper idle valve, they could be used directly for a tacho output. Ensure that the jumpers in section 3.5.4.3 are connected.

For other tacho output options, internal hardware modifications will be required.

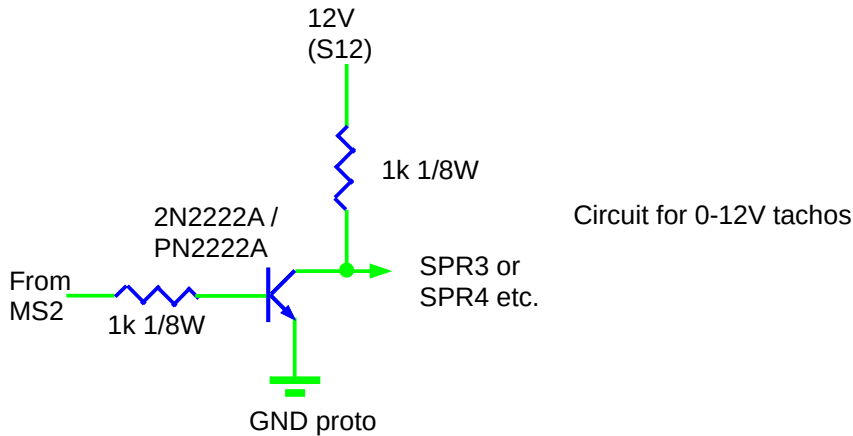

High-voltage tachometer can use a relay coil to generate the voltage "spike" they require. It is suggested that the mechanism inside the relay is removed or it will buzz loudly!

Alternatives to 2N2551 are ZTX458, MPSA42

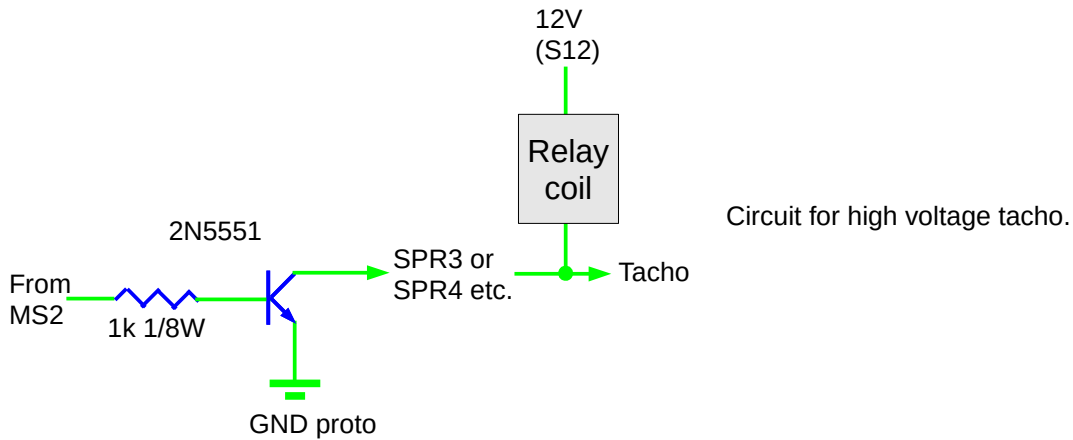

3.5.6 Other relay outputs

Other pins on the MS2 card can be reconfigured as outputs. Internal hardware modifications will be required.

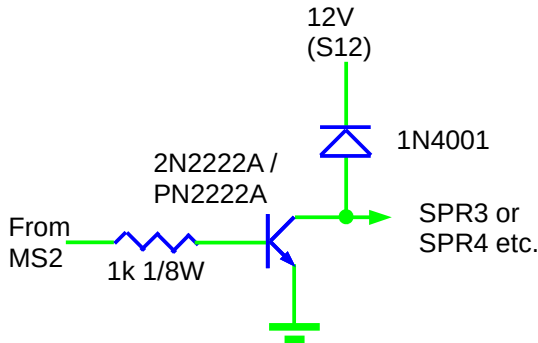

The "From MS2" connection is the specific CPU pin that you choose in TunerStudio.

Output pin name	Processor (DIP40) pin number	Note
IAC1/JS0	38	0-12V output.
IAC2/JS2	36	0-12V output.
JS4/AD7	30	Analogue input or digital input/output.
JS5/AD6	29	Analogue input or digital input/output.
JS10	17	Digital input/output.
JS11	18	Digital input/output.
D14	7	Digital output.
D15	9	Digital output.
D16	8	Digital output.
FIDLE	34	Digital output.

3.5.7 Boost control output

The boost control output requires a higher current transistor such as the TIP122. This needs a mica or similar insulator. Ensure that that 12V feed to the boost solenoid is supplied from the fuel pump relay or backfeeding

may occur.

This same circuit could be used to drive a small bulb such as a shift light instead of the solenoid.

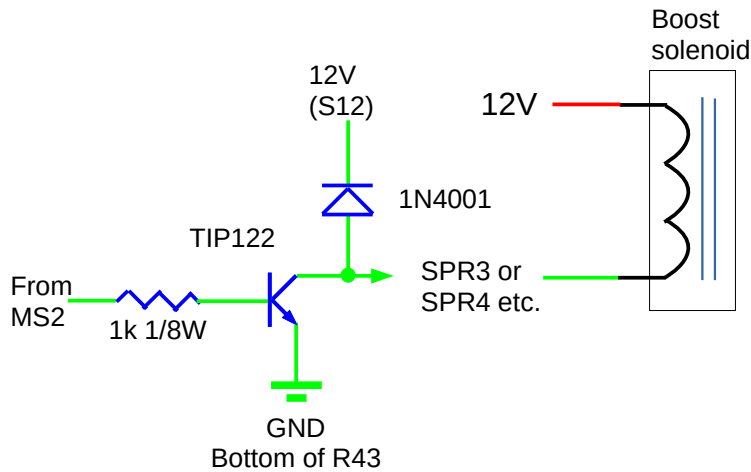

3.6 Inputs and Outputs Summary

The following chart lists all of the inputs and outputs on the MS2 and their typical uses. This may help you plan your wiring for optional features.

Pin	Analog in?	Digital in?	Digital out?	Prog. output	Typical use	Optional usage / notes
AD6/JS5	✓	✓	✓		EGO2	Analog in, digi in, digi output.
AD7/JS4	✓	✓	✓		Baro	Analog in, digi in, digi output.
D14			✓	✓	Spk A	Digital outputs only
D15			✓	✓	Spk C	Digital outputs only
D16			✓	✓	Spk B	Digital outputs only
FIDLE			✓	✓	PWM idle	Digital outputs only
IAC1			✓	✓	Stepper idle	Digital outputs only
IAC2			✓	✓		Digital outputs only
JS10		✓	✓	✓	Cam in	Digi in, digi output
PA0/JS11		✓	✓		Spk D	Digi in, digi output
PE0/JS7		✓			Launch	Digital inputs only
PE1/pin15		✓			Table switch	Digital inputs only
MAP	Usually MAP analog input. Can be used for MAF analog input with board modifications.					
MAT	Always MAT analog input.					
CLT	Always CLT analog input.					
TPS	Always TPS analog input.					
O2	Always O2 (lambda) analog input.					
INJ1	Always Injector bank 1 output.					
INJ2	Always Injector bank 2 output.					

Pin	Analog in?	Digital in?	Digital out?	Prog. output	Typical use	Optional usage / notes
Tach	Always primary tach (RPM) input.					
CANH/L	Always CANH/L signals.					

1. When used to drive a stepper motor, all four of IAC1A/B and IAC2A/B must be used, and cannot be used for other functions.
2. The IAC1A & B pins are complementary push/pull outputs; while one is connected to +12v, the other is grounded. IAC2 is the same.
3. For programmable output purposes, IAC1 ON means the A pin is high. IAC2 is the same.
4. Max combined sustained current through IAC1 & 2 is 0.5A

3.6.1 Pin vs. feature table

This is the list of I/O pins with available functions.

AD6/JS5	EGO2	Const Baro	Launch	Nitrous IN	Seq. Shift OUT	Seq. Shift IN	Knock	AC Idle - Out	AC Idle - In	Tach Out
AD7/JS4	EGO2	Const Baro	Launch	Nitrous IN	Seq. Shift OUT	Seq. Shift IN	Knock	AC Idle - Out	AC Idle - In	Tach Out
D14	Spark A				Seq. Shift OUT		Prog Output	AC Idle - Out		Tach Out
D15	Spark C			Nitrous OUT-2	Seq. Shift OUT		Prog Output	AC Idle - Out		Tach Out
D16	Spark B				Seq. Shift OUT		Prog Output	AC Idle - Out		Tach Out
FIDLE	PWM Idle	Boost Control		Nitrous OUT-1	Seq. Shift OUT			AC Idle - Out		Tach Out
IAC1	Step Idle *	Boost Control		Nitrous OUT-1	Seq. Shift OUT		Prog Output			Tach Out
IAC2	Step Idle *	Boost Control		Nitrous OUT-2	Seq. Shift OUT		Prog Output			Tach Out
JS10	2nd Trigger	Spark A	Launch	Nitrous IN	Seq. Shift OUT	Seq. Shift IN		AC Idle - Out	AC Idle - In	Tach Out
JS11	Spark D	Boost Control	Launch	Nitrous IN	Seq. Shift OUT		Prog Output	AC Idle - Out	AC Idle - In	Tach Out
PE0/JS7	Flex Fuel	Table Switch	Launch	Nitrous IN		Seq. Shift IN			AC Idle - In	
PE1/Pin15		Table Switch	Launch	Nitrous IN		Seq. Shift IN			AC Idle - In	

3.7 Bench test wiring

Before installing on your engine, it can be useful to install the Megasquirt on the bench to become familiar with the tuning software.

3.7.1 Minimal connection

The bare minimum for testing is a fused 12V supply, ground and the serial connection to your tuning computer.

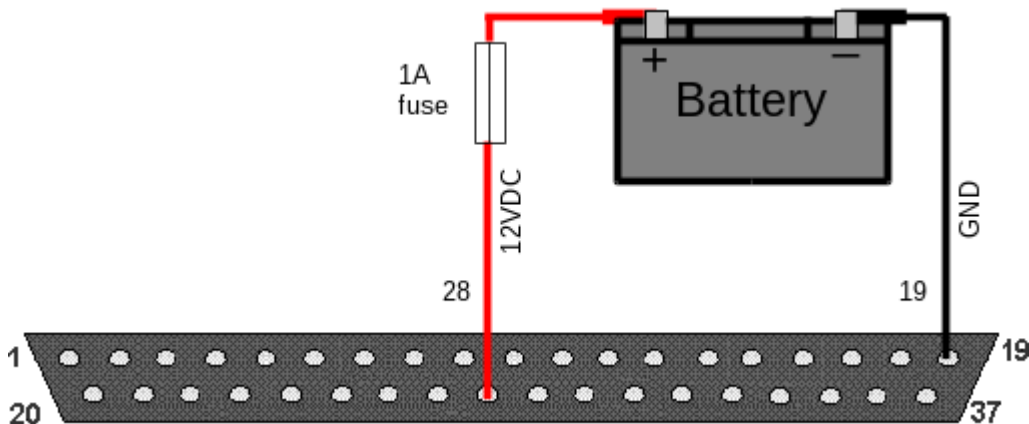

3.7.2 *JimStim connection*

For more extensive testing, the JimStim can be used. This has the mating DB37 connector to plug directly into your Megasquirt and can simulate many of the engine sensors. Make sure that the JimStim does not touch anything conductive as it is uninsulated.

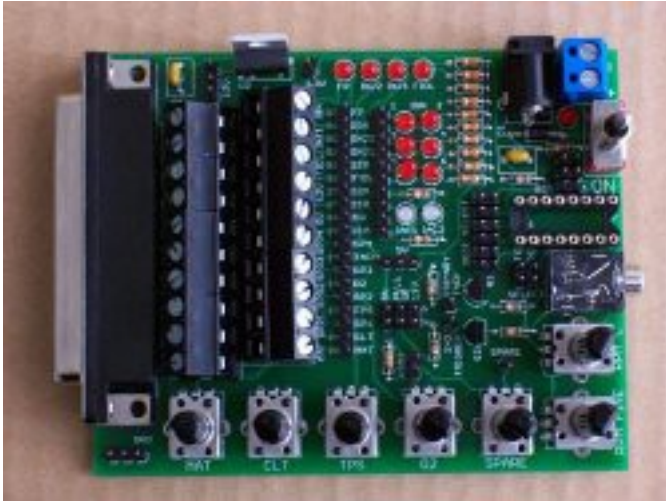

4 Fuel System



Fuel is extremely flammable and fuel systems run at high pressures. Be sure to have a fire extinguisher to hand in case of mishap and take appropriate caution when working on fuel systems.

4.1 Introduction

The fuel system install comprises electrical and plumbing work.

The Megasquirt has two injector outputs. These can supply up to 14A maximum each. Up to six injectors are allowed per channel.

The following shows a typical EFI fuel system.

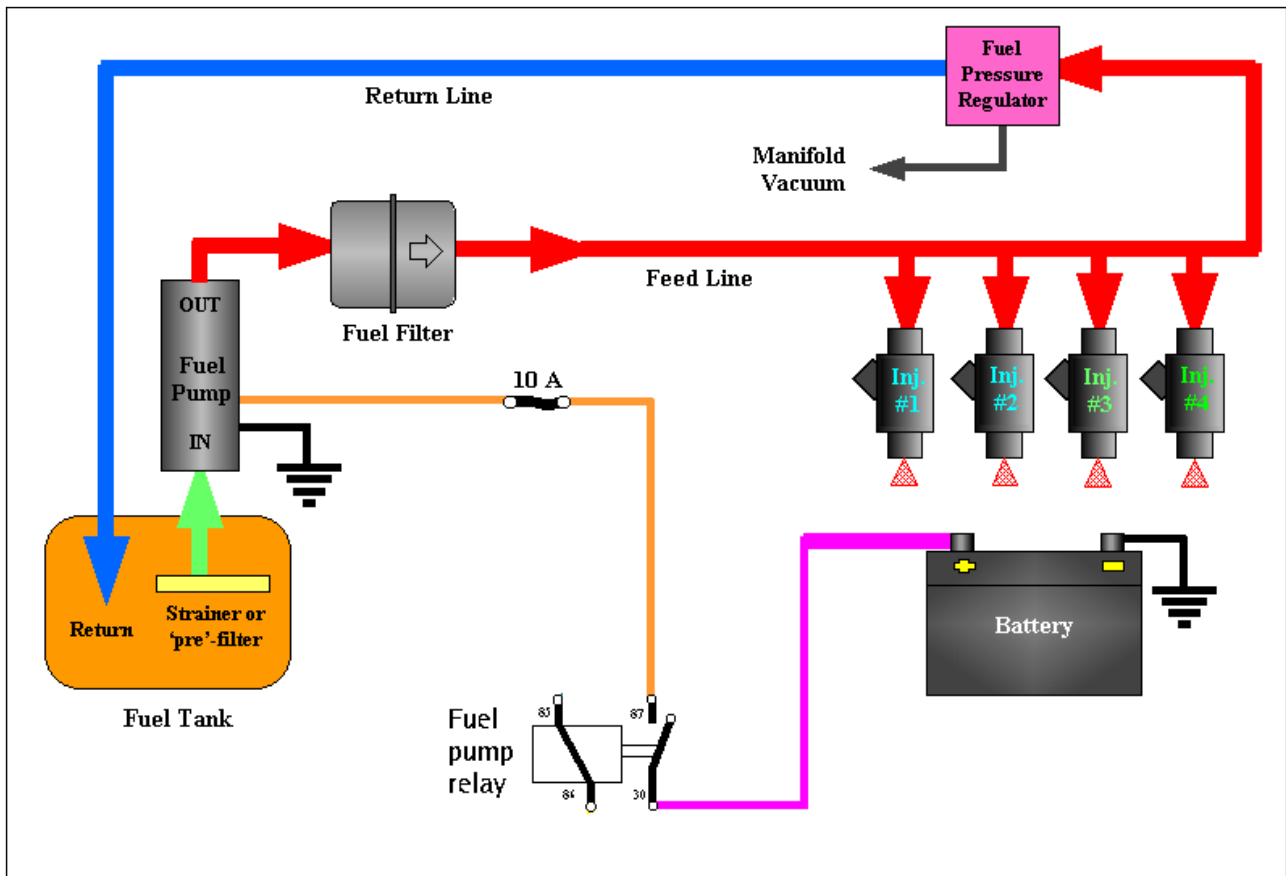

A high pressure pump is connected to the fuel tank and feeds fuel to the fuel rail(s) these provide fuel directly to the top of the injectors. The fuel rail(s) are connected to an intake manifold pressure referenced pressure regulator. The regulator maintains the rail pressure a set pressure above the intake under all conditions. Excess fuel is returned to the fuel tank through the return line.

Key elements

- Fuel pump
- Fuel hose/pipe and fittings
- Injectors
- Injector mounting

- Fuel rails
- Pressure regulator

4.1.1 Existing EFI Vehicle

Most vehicles with EFI already fitted are readily adaptable to use Megasquirt for control. Typically all of the fuel system components will be readily suitable.

However, if like many users you are increasing the power of your engine, you will need to consider whether your injectors are large enough and whether your fuel pump has adequate flow. In particular note that all fuel pumps flow less fuel as the pressure increases - so if you are boosting your engine you will be needing more fuel under the conditions when your pump can supply less!

Some recent engines use ECU controlled fuel pumps or dead-head systems with no regulator. At this time, these are not easily controlled and you are advised to convert to a conventional system with a vacuum referenced bypass regulator and return line.

4.1.2 Retro-fit EFI Vehicle

When installing EFI on a previously carburetted vehicle or a new build you have to source all the required fuel system components. There are many choices open to the retro-fit market. Be aware that a high horsepower install will often spend more on the fuel system than the ECU.

4.2 Single Fuel pump

You will need a high pressure pump with enough volume at your operating pressure to feed you engine under maximum load. Typical pressures needed in the neighborhood of ~45 psi for port fuel injection, ~10-20 psi for TBI injection. A port injection pump will work with TBI, but not vice-versa.

A standard EFI install uses a single high pressure pump connected as per the diagram in 4.1 above. Depending on your target power output, many OEM style pumps may be suitable. Surprisingly, some of the Bosch inline EFI pumps installed on 100hp cars are actually rated to 450hp fuel capacity. OEM style pumps are a usually a good choice as they are designed for trouble free operation for tens of thousands of miles.

OEMs sometimes place the pump inside the fuel tank. In an EFI retrofit it is generally easier to use an external fuel pump.

If an OEM style pump does not offer sufficient output, there are plenty of aftermarket high volume EFI pumps on the market.

4.3 Low pressure / high pressure - twin pump

For a basic retrofit, you may find that a low pressure/high pressure system is a simpler way to avoid tank modifications for the fuel pickup, although a fuel return to the tank is still required.

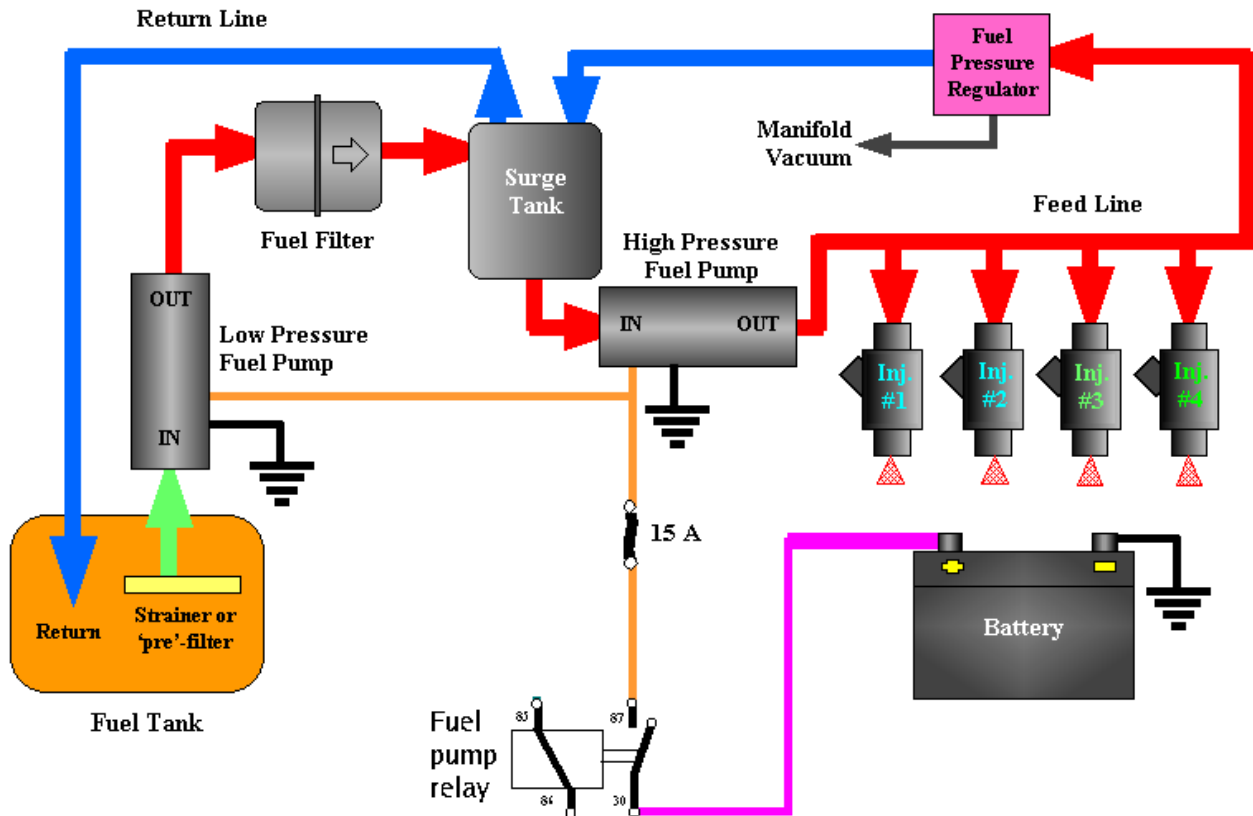

The low pressure side can be your existing electric fuel pump. You need to add the surge/swirl tank and high pressure side. For the tank return you may already have an return or evap canister connection or could connect into the filler neck, ensuring that fuel returns to the tank and cannot leak out of the vehicle. Surge/swirl tank can be purchased or you can make your own. Use thick wall TIGed aluminium or brazed steel. Ensure it is totally leak free.

4.4 Wiring the Fuel Pump

To activate the fuel pump, the Megasquirt provides a ground for the fuel pump relay circuit -see the main wiring diagram.

Ordinarily, at power on, the Megasquirt will run the fuel pump for 2 seconds, then when you start cranking the fuel pump is enabled again. If you stop cranking before the engine starts or you stall, the pump is turned off.

An inertial safety shut off switch is a good safety feature – it is used to kill power to the pump if there is significant impact to vehicle.

4.5 Fuel Line

Steel tubing or Cunifer (Bundy tubing) is recommended, but you MUST have short sections of flexible line in the feed and return lines between the engine and frame to allow for engine movement. The return line should have minimal restriction. For reference, GM systems typically have 3/8" feed lines and 5/16" return lines.

You may be able to use your original fuel line as a return line, plumbing a new 3/8" (10mm) line for fuel supply. You can run the return line into the tank, or reroute it to a fitting or nipple you install in the fuel tank filler neck/tube assembly (in which case you may be able to use the original pick-up for your supply line). If you run a new pick-up into the tank, it will need a filter.

You may have to fabricate fuel lines for your system. Tubing is available in steel, cunifer (bundy), stainless steel,

and aluminum for this purpose. Do not use plain copper and it can fatigue fail with dangerous leaks resulting. The size is generally given as the outside diameter of the tubing. Unless you have a very unusual combination (or very high horsepower, well over 500+), you should be able to use 3/8" tubing for both the supply and return lines.

Buy a good tubing bender (there are numerous styles in various price ranges) so that you don't kink or collapse the tubing while bending it.

Most fittings and adapters in the USA automotive aftermarket are based on a 37° sealing angle (SAE J514 37° -formerly known as JIC). These are also often referred to simply as AN fittings. Male and female 37° fittings will mate together for a leak-proof connection. Be aware that 45° fittings (commonly available in the USA) are not interchangeable with 37° fittings.

Abrasion (the rubbing of the hose against some other component) is the number one cause of hose failure. A leaking fuel hose can start a very dangerous fire in your car, so make sure hose assemblies are routed properly to reduce the chance of any abrasion damage. Use a support every 12 to 18 inches (30 to 45 cm) to secure the hose. For chafe protection, be sure to install a grommet at any point a hose passes through a panel or bulkhead.

Besides steel or aluminum tubing fuel line, you can also use one of the steel or nylon braided hoses from various suppliers. Generally these use the same AN 'dash' sizing system, and can use appropriate fittings to connect to 37° flare, NPT thread, or other systems.

Note that if you are using a factory fuel rail, you may be able to find an aftermarket adapter to mate your OEM fuel fitting to an AN hose.

IMPORTANT: Keep the fuel lines out of passenger compartment and routed safely away from moving or hot parts to avoid damage/excessive heat. For flexible rubber hose use the SAE 30R9 EFI hose which is rated at 250 psi. EFI hose clamps are also recommended rather than gear clamps. Check with someone who knows if you are not sure about your installation. Nobody needs a 50 psi gasoline fed fire to ruin their day!

4.6 Fuel filter

Use a fuel injection fuel filter rated for the pressure at which your system operates. **DO NOT** use a universal carburettor filter - the higher pressure of fuel injection systems may cause it to burst! Position the filter downstream of the pump so that a clogged fuel filter will not over heat the fuel-cooled pump. However, if you fuel pickup does not include a strainer, it is wise to install a coarser filter ahead of the pump. When using original old steel fuel tanks, pieces of rust can dislodge and jam the fuel pump.

4.7 Fuel Pressure Regulator

The vacuum referenced fuel pressure regulator is essential. It provides constant pressure differential between fuel at injector nozzle and manifold air pressure [port EFI] or atmospheric pressure [TBI]. This makes the injected fuel quantity solely a function of the injector open time. Without the vacuum/boost reference connection you would need an excessively small pulsewidth under cruise/idle and an enlarged pulsewidth under wide open throttle or boost. Make sure the regulator is connected to a full vacuum source, not ported-vacuum. Check it has vacuum with the engine idling and the throttle shut.

If you have an adjustable fuel pressure regulator (FPR), set the pressure with the fuel pump running, but the engine not running - that's your base fuel pressure (it is referenced to atmospheric pressure).

The regulator is typically at the far end of the fuel rail (after the injectors) which recirculates all of the fuel, keeping it cool and free from air pockets. However, it can be installed anywhere after the fuel pump, but you may experience fuel heating and air pockets.

If you are using an aftermarket fuel pressure regulator, it is a good idea to also install a pressure gauge, since most of these are adjustable. For TBI, use a 0-30 psi gauge. For port injection use a 0-60 psi or 0-100 psi gauge. Most of these gauges will mount directly on a fuel fitting using a 1/8" NPT thread.

4.8 Injector installation

Many "high performance" vendors offer ready made EFI intake manifolds for engines that did not originally come fitted with EFI. Or you can choose to modify your existing intake by welding, glueing or screwing in injector bungs. Many aftermarket vendors offer suitable injector bungs.

4.9 Fuel Rails

Most injector systems will use one or more fuel rails. These serve two functions: they supply fuel to a multiple number of injectors (4 on a 4 cylinder, for example), and they physically locate the tops of the injectors. Most OEM rails can be made to work with standard engine configurations, but if you are doing a custom conversion you may have to fabricate fuel rails. Many place supply blank aluminum fuel rail extrusions in whatever length you need.

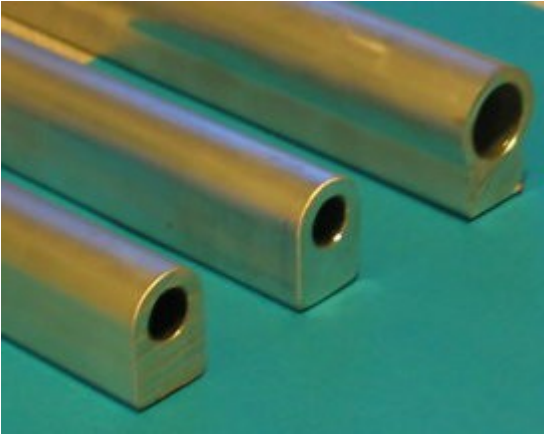

4.10 Fuel Injectors



4.10.1 Injector Size

It is important that your injectors are correctly sized for your engine size and power requirements. Too small and you will run out of fuel at high power and rpms, with likely engine damage from going lean. Too large and you will encounter tuning difficulties for idle and cruise conditions.

You can use the following chart to select injectors based on the total horsepower of your engine and the total number of injectors:

Horsepower	Injectors Rating Required in cc/min (lbs/hr)					
	Number of Injectors					
	1	2	4	5	6	8
100	620 (59)	305 (29)	158 (15)	126 (12)	105 (10)	-
150	924 (88)	462 (44)	231 (22)	189 (18)	158 (15)	116 (11)
200	-	620 (59)	305 (29)	252 (24)	210 (20)	158 (15)
250	-	777 (74)	389 (37)	305 (29)	263 (25)	189 (18)
300	-	924 (88)	462 (44)	368 (35)	305 (29)	231 (22)
350	-	-	524 (51)	431 (41)	357 (34)	273 (26)
400	-	-	620 (59)	494 (47)	410 (39)	305 (29)
500	-	-	777 (74)	620 (59)	515 (49)	389 (37)
600	-	-	924 (88)	746 (71)	620 (59)	462 (44)
800	-	-	1239 (118)	987 (94)	819 (78)	620 (59)
1000	-	-	1544 (147)	1240 (118)	1030 (98)	777 (74)
1500	-	-	-	-	1575 (150)	1187 (113)
2000	-	-	-	-	-	1554 (148)

Based on 0.50 BSFC and 85% duty cycle

Turbo/supercharged engines should add 10% to listed minimum injector size

Injectors are usually rated in either lbs/hour or cc/min. The accepted conversion factor between these depends somewhat on fuel density, which changes with formulation (i.e., by season), but the generally used conversion for gasoline is:

1 lb/hr ~ 10.5 cc/min

Another way to select injectors is to take them from an engine that makes nearly the same power as your engine will [assuming the same number of injectors].

If your regulator is adjustable (many aftermarket ones are), you can also adjust the fuel pressure to achieve different flow rates. Changing the fuel pressure doesn't affect the flow rate as much as you might assume, since it is based on the square root of the pressure ratio. The formula is:

$$\text{new flow rate} = \text{old flow rate} \times \sqrt{(\text{new pressure} \div \text{old pressure})}$$

So for example, if you had 30 lb/hr injectors rated at 43.5 psi, and you went to 50 psi, you would get:

$$\text{flow rate} = 30 * \sqrt{(50/43.5)} = 32 \text{ lb/hr}$$

Do not run more than 70 psi fuel pressure, or the injectors may not open/close properly.

However, do not install injectors with a much larger flow capacity than you need. Very large injectors will create idle pulse width issues that will make tuning very difficult.

4.10.2 Injector Impedance and wiring

Injectors can typically be categorized as either high impedance (hi-z, high-ohm, saturated) or low impedance (low-z, low-ohm, peak and hold.) It is important to know which type your injectors are. Both types can be used with Megasquirt although high impedance tend to be easier to use.

New injectors will specify which type they are or list the ohms. If you are unsure, measure them with your meter on the ohms setting.

- High impedance injectors are typically 12-16 Ohms.
- Low impedance injectors are often 2.5 Ohms or less.

Do not simply connect and hope.

4.10.2.1 High impedance injectors (12-16 Ohms)

These injectors can be directly connected to the Megasquirt. No need for injector resistors and Injector PWM should be turned off.

Up to 6 injectors per channel may be connected.

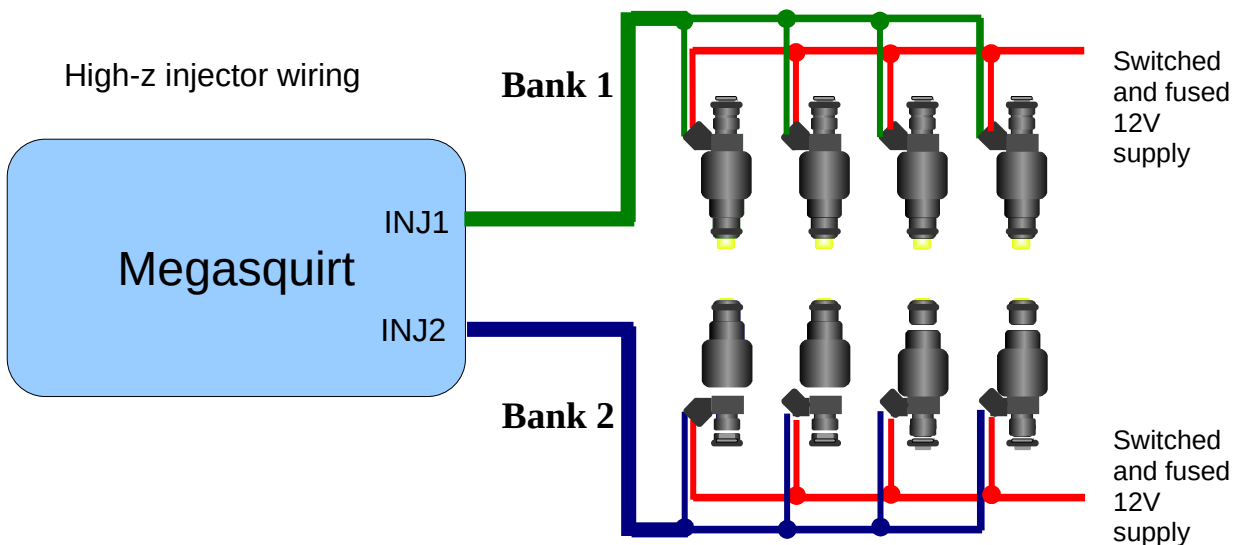

4.10.2.2 Low impedance injectors (less than 3 Ohms)

These injectors can be used, with a few connection options.

- Injector PWM
- Injector resistors
- External peak-and-hold adapter

4.10.2.3 Low impedance injectors - Injector PWM

Injector PWM is built into the MS2/V3.0 and allows direct connection of low-z injectors. The PWM mode is effectively "peak and hold" controlled by software. At each injection event, full power is applied to the injector until it opens, then the output drops back to a pulsed output to hold the injector open.

During cranking full current is applied to the injectors.

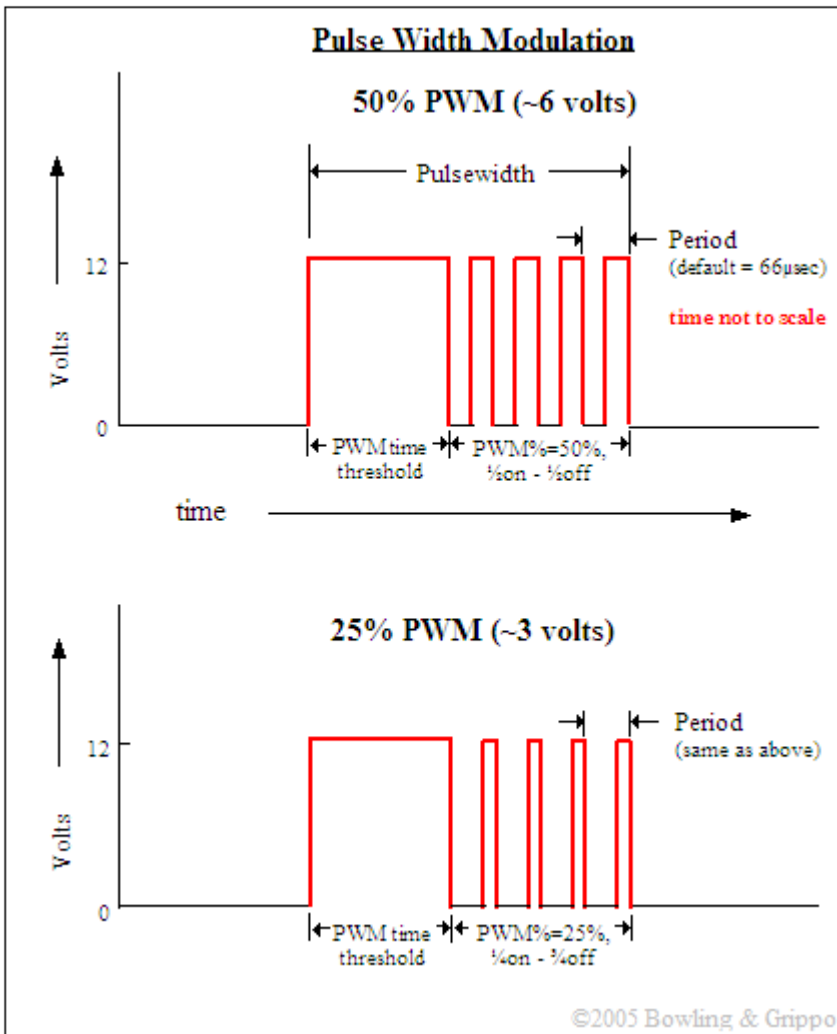

30% PWM duty is recommended with MS2/V3.0.

Be sure that you have sufficient power grounds from your Megasquirt to the engine.

A small number of installs have reported interference from the PWMing of injectors. Re-routing the flyback current can help. (See 13.6.)

4.10.2.4 Low impedance injectors - Injector Resistors

This method has been used by many OEMs as a simple approach to driving low-z injectors. The installer has the option of installing a power resistor (typically with a 20 to 25 watt rating) in series with each injector (in effect converting them to high impedance.)

The series resistors will slow down the opening of the injector slightly, so it is suggested that the resistance of the resistors be kept to a minimum but staying within the 14A limit of each injector channel. One resistor must be used for each injector - do not try to share resistors.

For typical 2.5ohm low impedance injectors, the following resistances can be used

Number of injectors per channel	Resistor value
1	3.3 ohm
2	4.7 ohm
4	10 ohms

The resistors should be mounted to a suitable heatsink (e.g. a thick piece of aluminium plate) as they will get hot in operation.

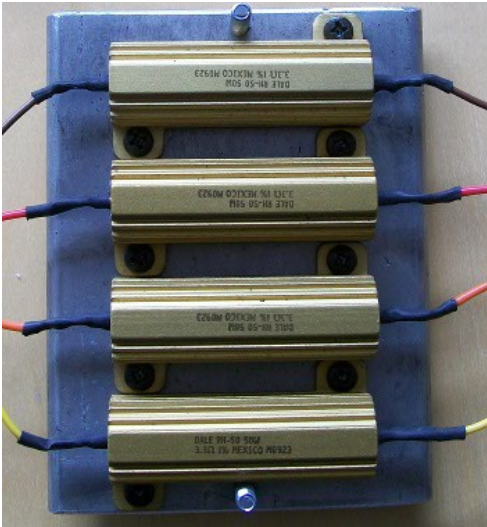

Low-z injector wiring with resistor

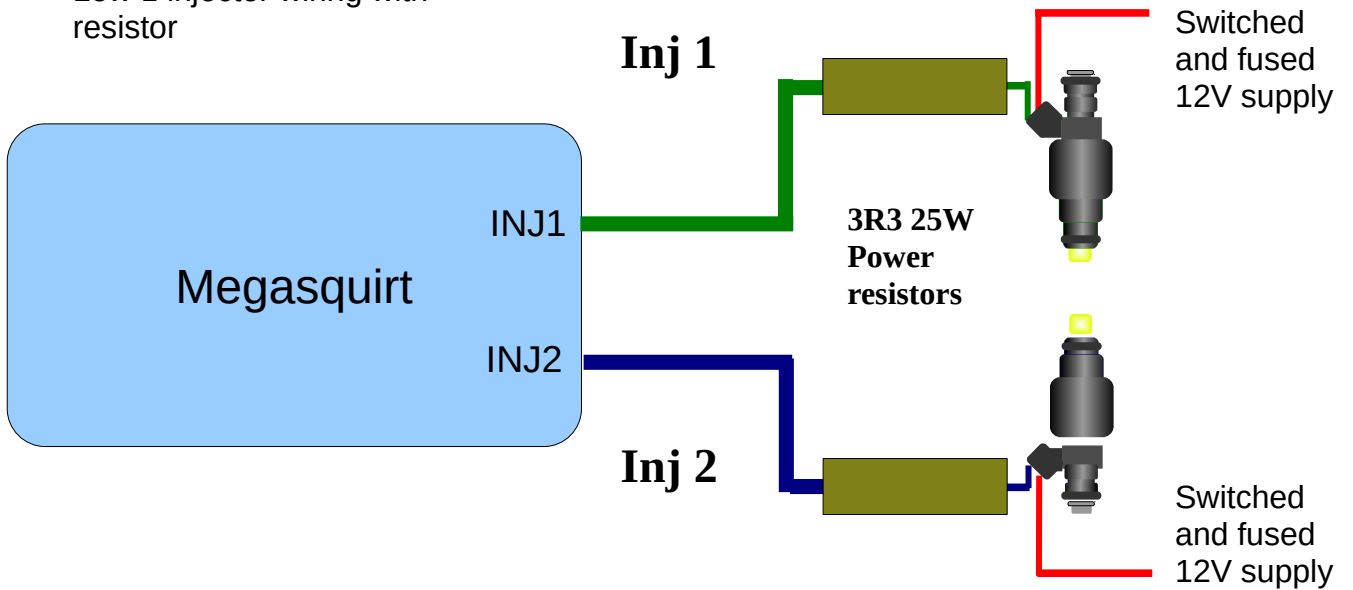
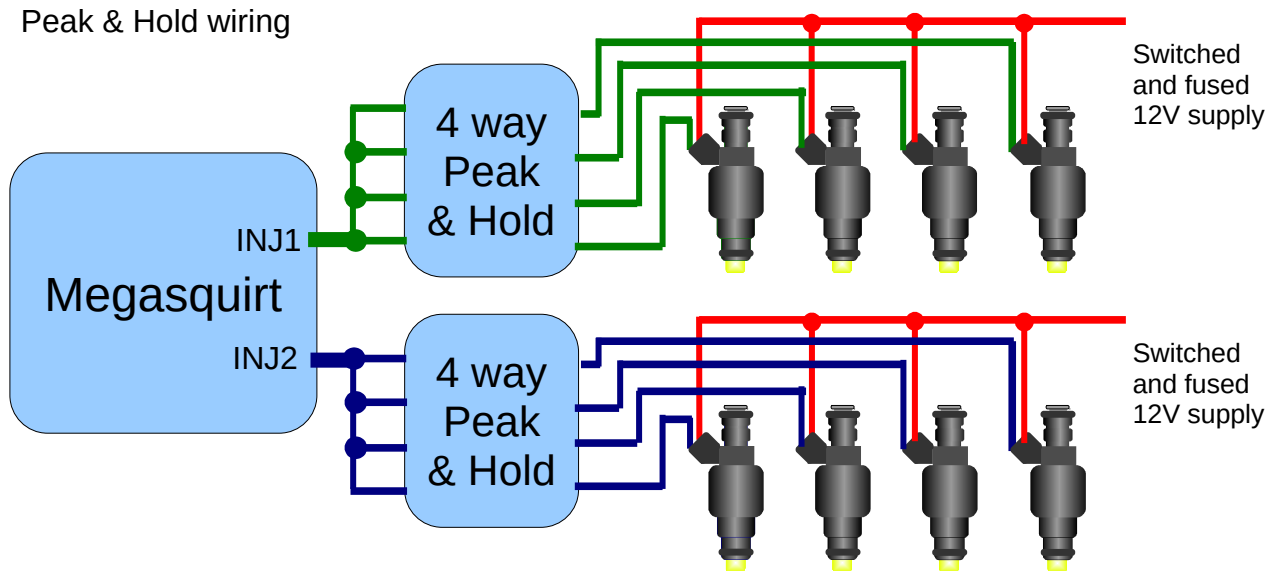

Diagram showing one injector per channel and 3.3 ohm series resistors.

4.10.2.5 Low impedance injectors - Peak and hold

Aftermarket peak and hold controllers are available, these take the low-side injector output from the Megasquirt and provide the required peak and hold drive for the injectors. Typically this is a peak to 4A and then a hold at 1A.

Refer to supplier's documentation for exact wiring - the following diagram is representative only.



4.10.3 Staged injection

Staged injection is a method that allows for two sets of injectors to give a better dynamic range of fueling - more precise control at idle, but still flowing enough fuel at full load. Typically, at low load, idle or cruise only the smaller primary injectors are in operation. At higher fuel demands, the secondary injectors are enabled.

When using "Staged Injection" the primary injectors are connected to INJ 1 and the secondary injectors are connected to INJ 2.

See the TunerStudio reference manual for configuration details.

4.10.4 Sequential injection 'mod'

Not recommended for novice users!

With some fairly extensive internal hardware modifications and the addition of extra drive circuits, the MS2 can run sequential injection on four outputs giving fully sequential fuel on a 4-cyl and semi-sequential on an 8-cyl.

This modification removes the injector PWM feature, so low-z injectors cannot be driven directly.

To use the additional injector drivers, the MS2 card needs to be modified as shown below. This modification requires the removal of the MegaSquirt board clock circuit which was only used by the MS1 CPU.

Also, the modification will require the use of 4 identical injector drivers. There are three main options to achieve this.

- Duplicate the existing INJ1, INJ2 channels from the mainboard.
- Use a peak&hold solution for all four channels (for low-z)
- Use an injector driver board for all four channels (for high-z)

The picture below shows the MS2 card modification which connects pin 1 of the NAND gate chip (U2) on the MS2 card to pin 4 of the 40-pin header and pin 4 of U2 to pin 5 of the header.

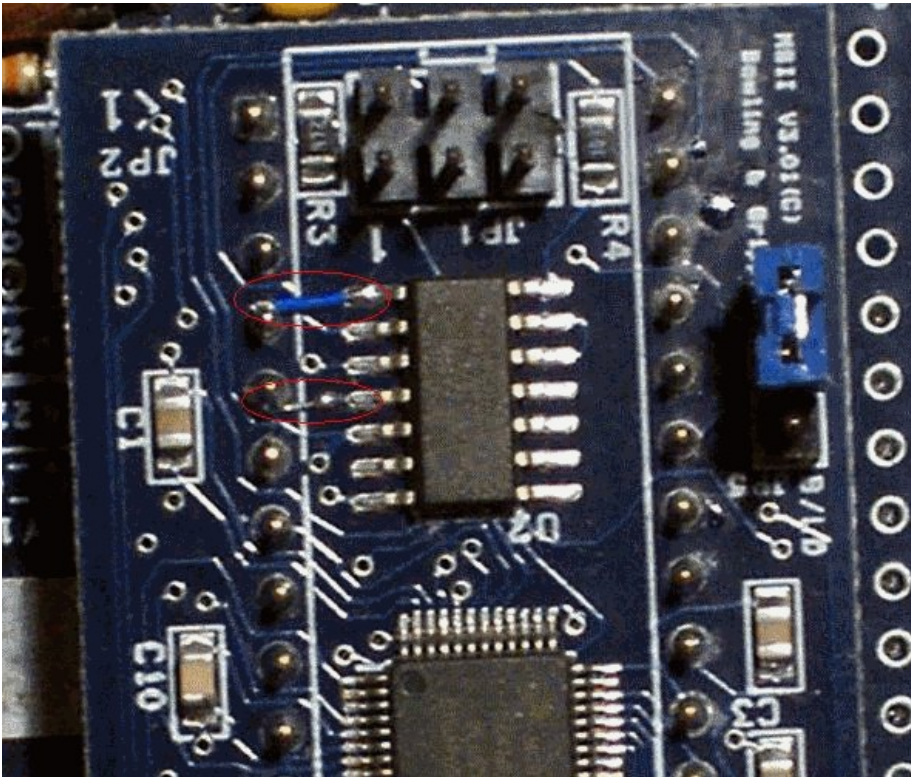

With that modification, pins 3 and 7 of the MS2 CPU can be used for injector channels 3 and 4, respectively. They now connect to pins 4 and 5 of the pin header. It should be noted also that the CPU pins corresponding to injector channels 1 and 2 are already directly connected to the 40-pin header at pins 39 and 40.

(The schematics for the MS2 and V3.0 mainboard are provided in the appendix section.)

The picture below shows the placement on the V3.0 board of the 4 injector channels. The injectors channels 3 and 4 connect to pads originally used for the MS1 clock circuit and require the removal of those components for proper and safe operation. The injector channel 3 shows 2 pads because they correspond to the same electrical location (use either one). The components to remove are: R21,C20,C21,R22,R23,Y1,C24,C25.

In the case where you are using a peak&hold solution or a 4-way injector driver board, the standard injector drivers components can be left on the board but will be unused and will not interfere with injector channels 1 and 2.

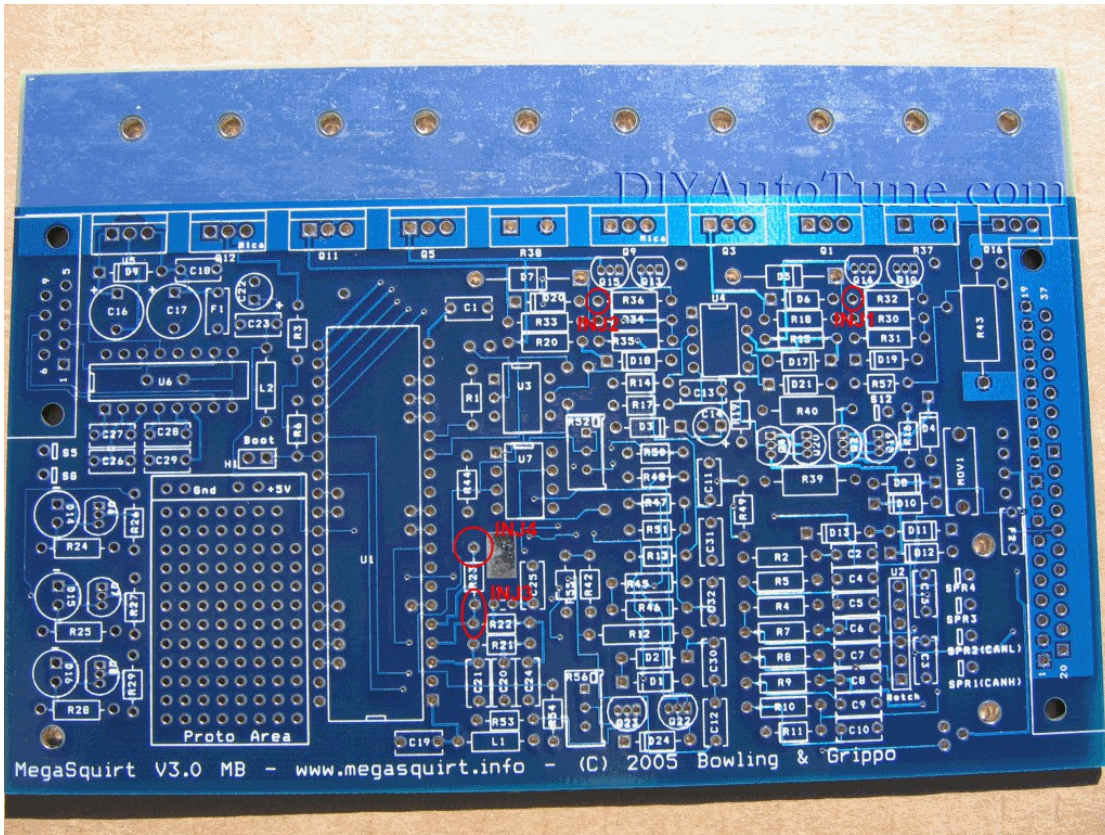

Two complementary pieces of hardware that may be of use for the sequential modification come from JBperf.com

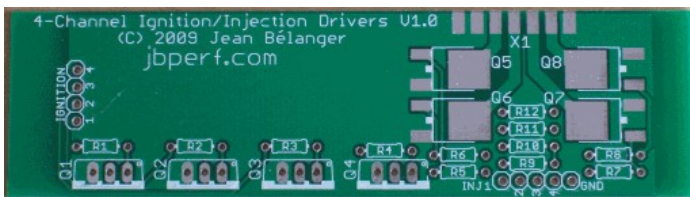

4 way high-z driver board

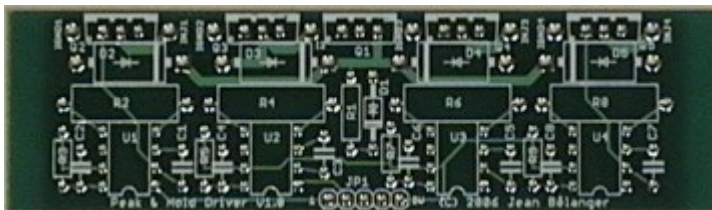

4 way peak&hold low-z driver board

5 Ignition System - fundamentals

The ignition system comprises both the crank and cam tach inputs and the ignition outputs to drive coils. There are many different combinations possible, this chapter will describe some of the possibilities.

Note: A tach input is required on ALL installs including fuel-only.



Ignition systems produce dangerous voltages in excess of 30,000V. Take care to avoid shock.

5.1 Ignition system design

The following sections describe the details of how to connect your ignition system, first we'll take an overview.

The installation of a new ECU is a good time to review the existing ignition system on an engine. Older engines pre-dating EFI may be using a points ignition and anything up to the 1990s may still use a distributor. While these systems do work (kind-of) there are plenty of superior methods available now that you are strongly advised to consider.

Some downsides to the older-tech methods:

- Points - when used to control the coil directly they would eventually burn out and could require frequent re-adjustment for reliable operation.
- Distributor - on many engines this is driven from the cam-shaft or cam-belt. As this is not directly related to the crank position, there is an inherent timing scatter and 'slop'. Distributing the high-tension spark energy through the rotor arm and distributor cap wastes a number of kilovolts jumping the gap.
- Single coil - at higher revs, there may not be enough time to charge a regular inductive coil. On a V8 engine, the dwell can become compromised above 5000RPM.

Some older solutions:

- Electronic pickup in distributor - gets rid of many of the points problems
- CDI ignition (e.g. MSD box) - maintains spark energy at high RPMs with a single coil, but short duration spark may not be as good at idle or with lean mixtures.
- Crank trigger - eliminates distributor slop

Suggested solutions:

- Missing tooth crank wheel - gives accurate engine position for good timing control
- Multiple coils - can keep long duration inductive spark and retain spark energy at high RPMs

Many factory engines from 1990 or newer already incorporate a crank trigger wheel and multiple coils. Often these can be used as-is. On older engines, do consider upgrading your ignition hardware for a more successful install.

5.2 Crank and Cam tach inputs

The tach input is one of the most important signals going into the Megasquirt and correct system operation is not possible until the tach input is correctly installed and configured. **Until the Megasquirt reads the correct RPM, nothing else will work.**

Even if you are starting with fuel injection only (not controlling ignition) you must still provide the Megasquirt with a tach input - see coil negative triggering in section 5.2.1

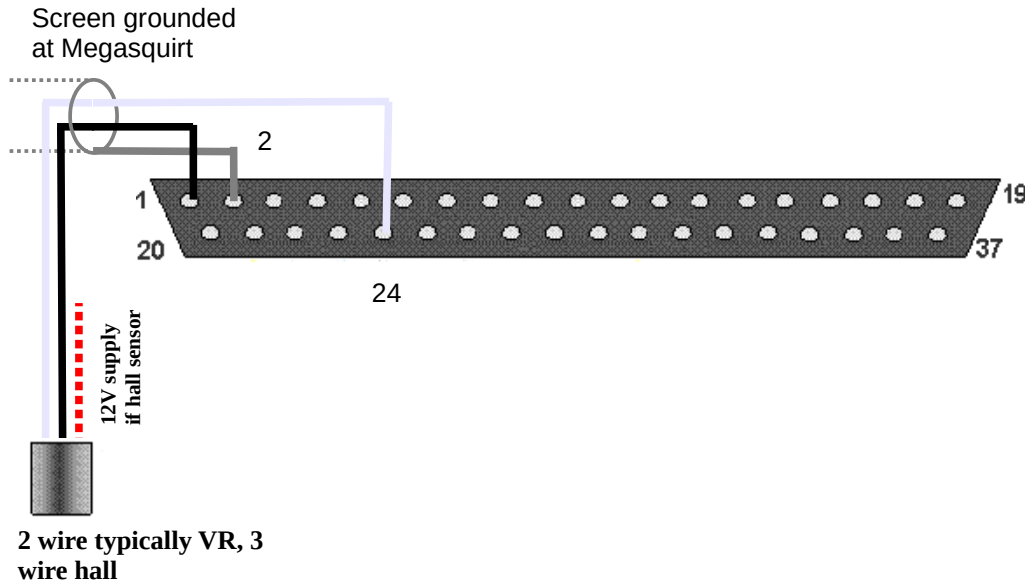

The MS2/V3.0 as standard has a single tach input. You must customize the board internally to select whether this input connects to the opto-isolator input for coil-negative triggering, or to the 'universal' tach input circuit.

Installs requiring a second tach input (cam sensor or part of a CAS) will require additional internal modifications. See section 5.2.14

There are many different options for tach input and this is probably one of the largest areas of difficulty with any after-market EFI install. The firmware contains software decoders to suit many stock installs using original sensors. If your engine is supported, then this is the recommended approach.

Two key pieces of information you need to know are:

- Sensor type(s)
- Trigger wheel pattern

The sensor types fall into a few basic families of sensors and the right way to use the sensor depends more on the type rather than the particular vehicle or manufacturer. There are also a few "special" systems in use from the eighties that combine a sensor input with an ignition driver output in one module. These will be discussed later - Ford TFI, Ford EDIS, GM HEI, GM DIS.

If you are considering an after-market, non-OEM sensor you must ENSURE that it has a suitable temperature rating. Typically engines run at around 100°C/212°F so a minimum of 105°C rating is required, 125°C desired. Do not consider using 85°C rated parts around the engine as they will degrade and cause you trouble. Be aware of heat radiated from exhaust components - these can overheat sensors and cause failure.

5.2.1 Coil Negative Input

For fuel-only installs it is possible to obtain a tach in trigger from the negative terminal of a single coil.

Coil negative (not CDI)

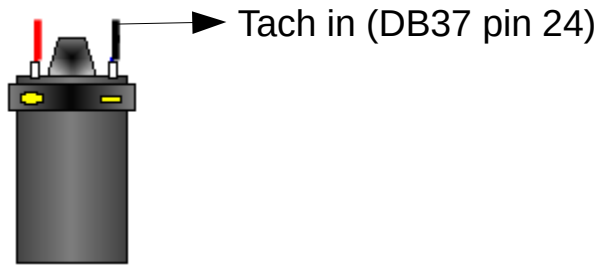

Opto-isolator (for coil negative fuel-only triggering):

- a) Fit a 36V Zener Diode in reverse into position D2. Note, the Zener Diode must be fitted backwards, so the strip on the diode is the opposite end to the stripe on the main board! (This component is part of the kit from good suppliers)
- b) Ensure C30 is fitted. (This is needed for noise elimination)
- c) Ensure D1 is fitted.
- d) Ensure R12 is fitted (390R 1/2W)
- e) Solder a jumper from XG1 to XG2. In exceptionally noisy situations it might be required to remove that jumper and instead runs XG1 out through a spare connection on the DB37 and through the wiring harness direct to the engine.
- f) Link TACHSELECT to OPTOIN
- g) Link TSEL to OPTOOUT



See also section 6.1 for fuel only setup.

5.2.2 VR (magnetic) sensor input



The VR sensor is a very commonly used sensor. Usually it is seen as a two wire sensor although some manufacturers install a screen on the cable, so yours may have three wires. In CAS (crank angle sensor) units a multiplug may be used to combine multiple sensors. The sensor itself generates an AC voltage when a piece of steel (the trigger) moves past it. Non-ferrous trigger wheels will not work. The voltage varies from less than a volt during cranking to tens of volts at higher revs.

Typically it is suggested that the magnetic tip of the sensor is around the same size as the teeth on the wheel.

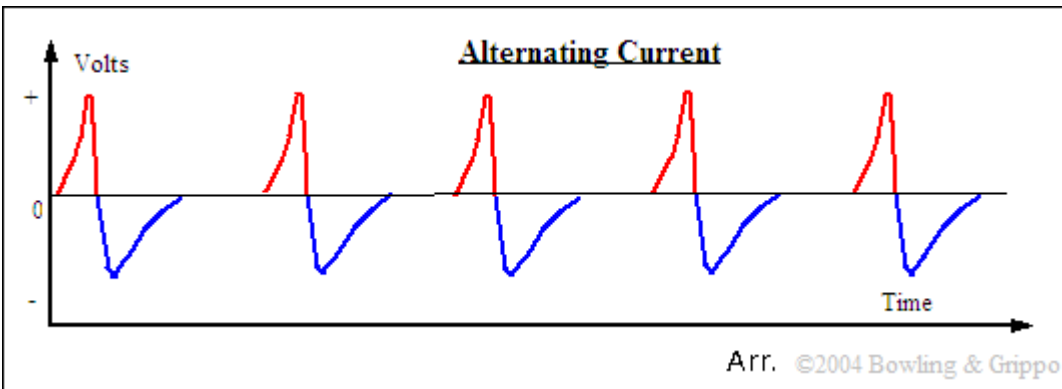

In order to use a VR sensor a "conditioner" circuit is required to convert the AC voltage into a DC square wave signal while retaining the timing information. The Megasquirt has this conditioner built in. The two signal wires from the VR sensor are connected to Tach-in and GND at the Megasquirt. Ideally use a screened twisted pair cable and connect the screen to sensor ground at the Megasquirt end only.

VR sensor

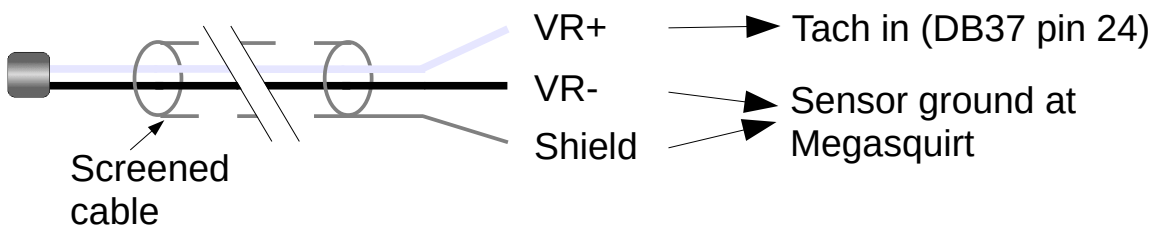

The mainboard needs to be set as follows:

VR Input for VR (magnetic) sensor

- a) Solder a link between VRIN and TACHSELECT



- b) Solder a wire between VrOUT and TSEL



- c) With a small screwdriver, turn the pots, R52 and R56, about 12 turns anticlockwise (sometimes you may feel a "click" when the end position is reached, they can't be damaged by turning too far.) This sets them up for most VR sensors.

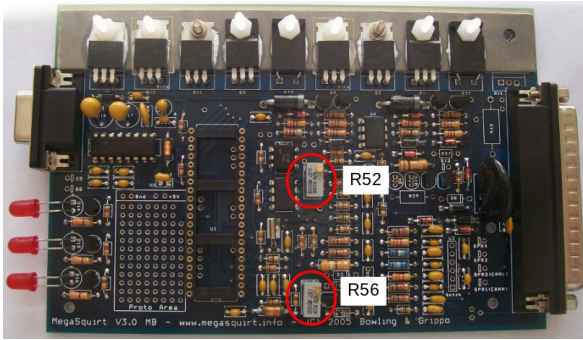

Optionally, when adjusting R56, you can measure the voltage at the "top" of R54. You'll need the board powered up. Set your meter to volts, and connect the +ve probe to the top of R54 and the -ve probe to ground. Adjust R56 to get the lowest voltage on your meter.

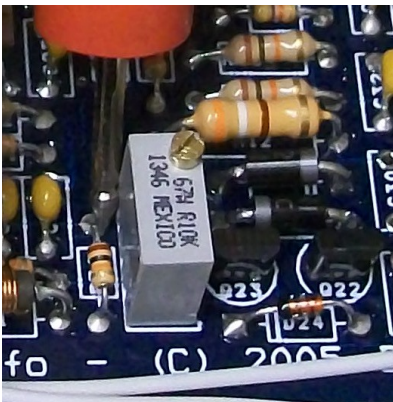

Some installs may find it necessary to install a resistor inline with the VR+ wire to reduce the signal voltage at higher RPMs. Typically a 10k 1/4W resistor is sufficient.

5.2.3 Hall sensor input

The Hall sensor is another commonly used category of sensor. These are almost exclusively a three wire sensor. In CAS (crank angle sensor) units a multi-plug may be used to combine multiple sensors. The sensor itself acts like a switch to ground in the presence of a magnetic field. Hall sensors are commonly seen in distributors where vanes or shutters mask off the magnetic field causing the sensor to rapidly switch on or off at the edge of the vane. Another way that a hall sensor can be used is with a "flying magnet" installed on a rotating part of the engine (crank, cam sprocket etc.). As the magnet passes the hall sensor, the output switches to ground.

The most common OEM arrangement for a hall sensor is within a distributor. The vanes in the distributor rotate and block or unblock a magnet.

With no vane between the magnet and sensor - the output is grounded.

With a vane between the magnet and sensor - the output is inactive.

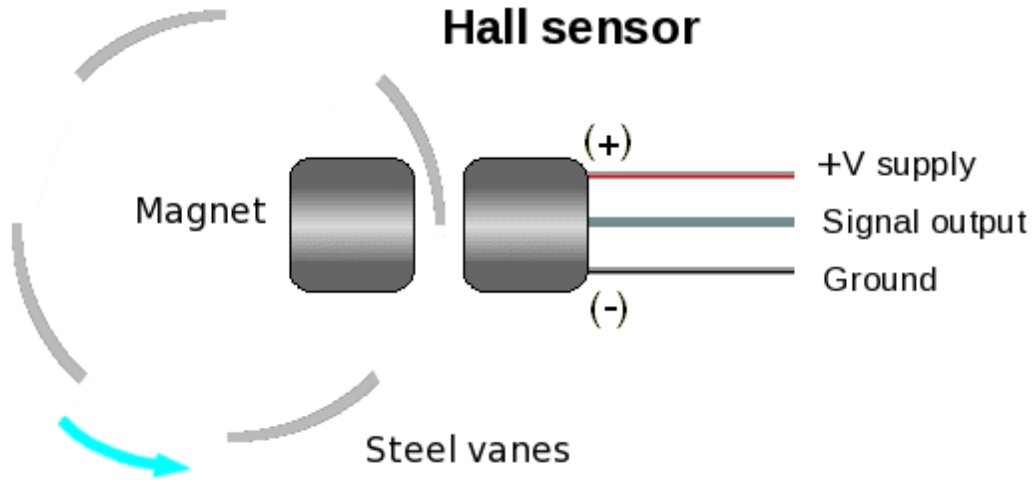

Above: diagrammatic representation.

Below: OEM dizzy modified to make single-tooth cam trigger.



There are two main categories of hall sensor

- open-collector (needs a pull-up resistor)
- built-in pull-up resistor (covered in section 5.2.4)

Hall sensor (open collector)

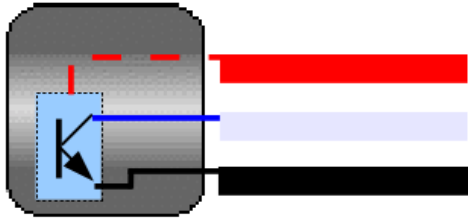

Equivalent circuit

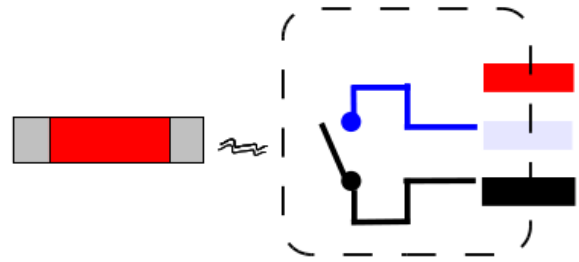

Sensor gives a ground in presence of a magnet.
Gives floating (no output) with no magnet.

Pullup resistor REQUIRED.
(Either in loom or inside ECU.)

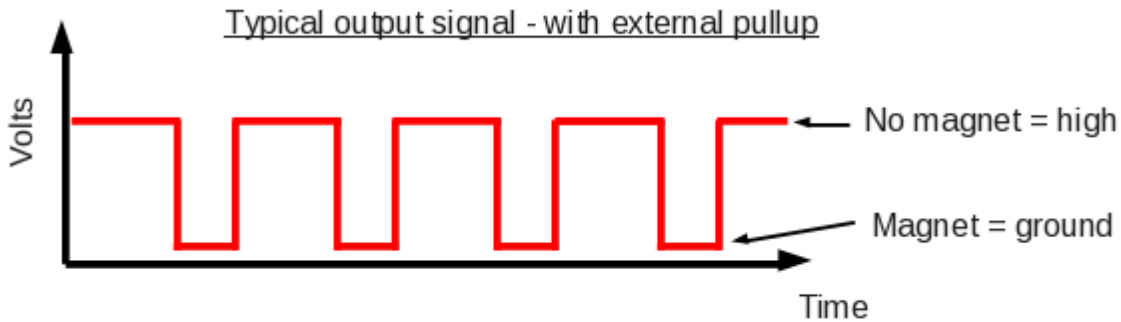
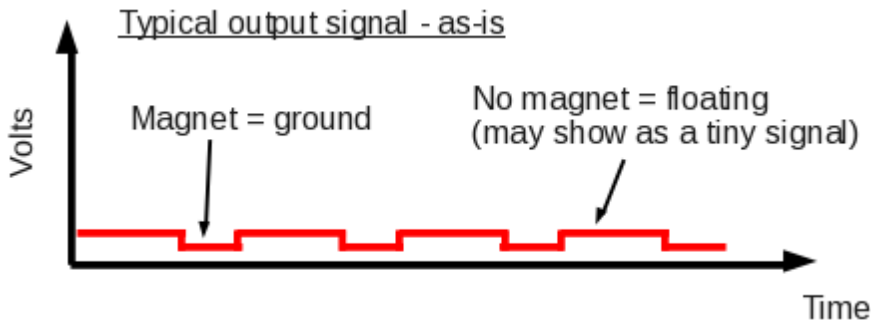

The hall sensor requires a supply voltage which is usually 12V from a fused 12V supply or 5V from the TPSREF output of the Megasquirt. The sensor is then grounded at the Megasquirt sensor ground and the signal wire connects to the Tach input. A pull-up resistor is required in the wiring harness or inside the Megasquirt.

Hall / geartooth / logic / optical sensor

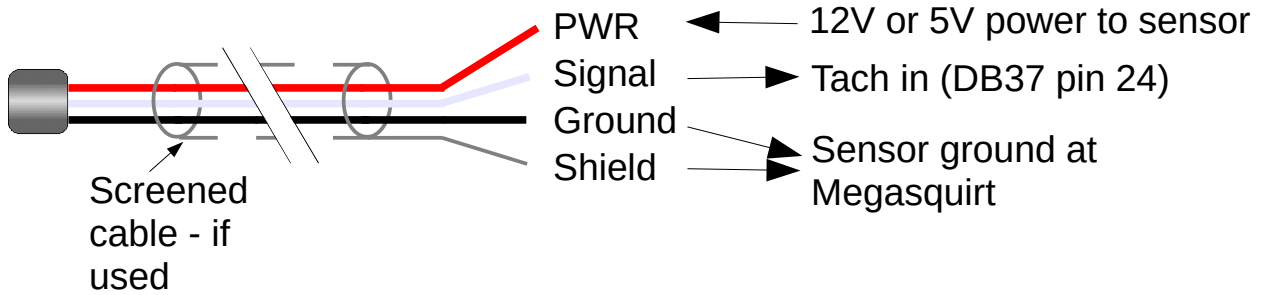

VR Input with pullup for hall sensors, LS2/58X, optical sensors or points

a) Solder a link between VRIN and TACHSELECT



b) Solder a wire between VrOUT and TSEL



c) Install a 1k resistor (any value 470R - 2k2 is likely OK) in the proto area. Connect one end to the 5V hole and join the other end to VRIN with a jumper wire.

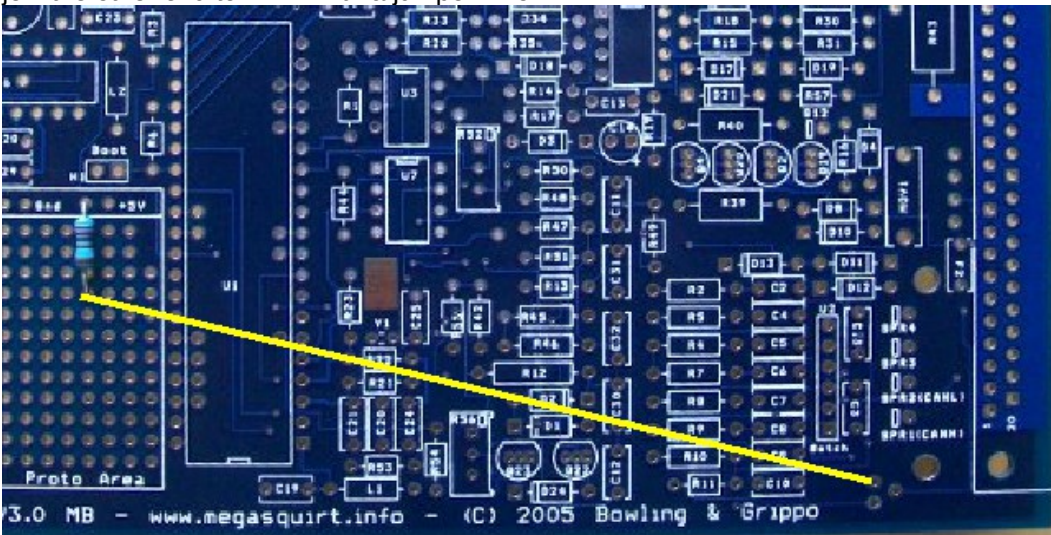

d) With a small screwdriver, turn the pots, R52 and R56, about 12 turns anticlockwise (sometimes you may feel a "click" when the end position is reached, they can't be damaged by turning too far.) and then turn R56 back about 6 turns clockwise.

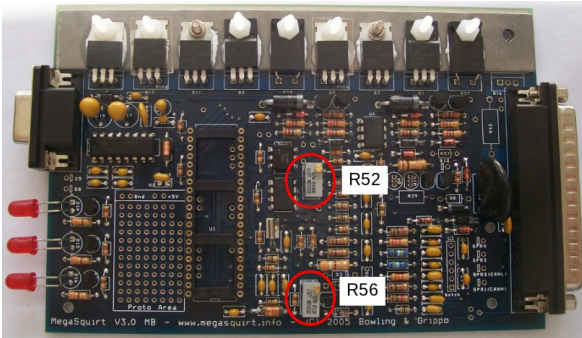

Optionally, when adjusting R56, you can measure the voltage at the "top" of R54. You'll need the board powered up. Set your meter to volts, and connect the +ve probe to the top of R54 and the -ve probe to ground. Adjust R56 to get around 2.5V on your meter.

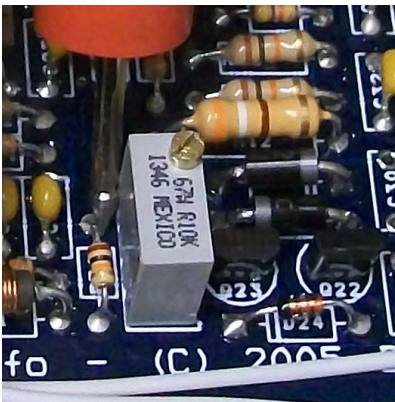

5.2.4 Hall sensor input (built-in pull-up)

These sensors operate similarly to the hall sensors in section 5.2.3 but include the pull-up resistor internally so they give a 0V or 5V signal.

Hall sensor (built-in pullup)

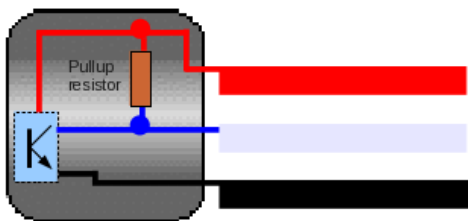

Equivalent circuit

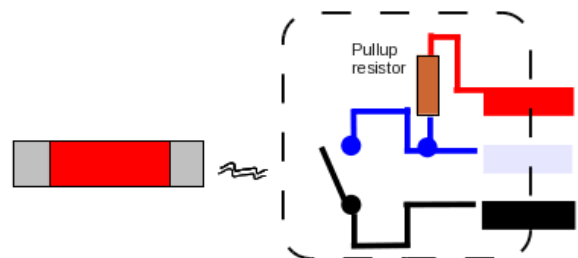

Sensor gives a ground in presence of a magnet.
Gives positive voltage with no magnet.

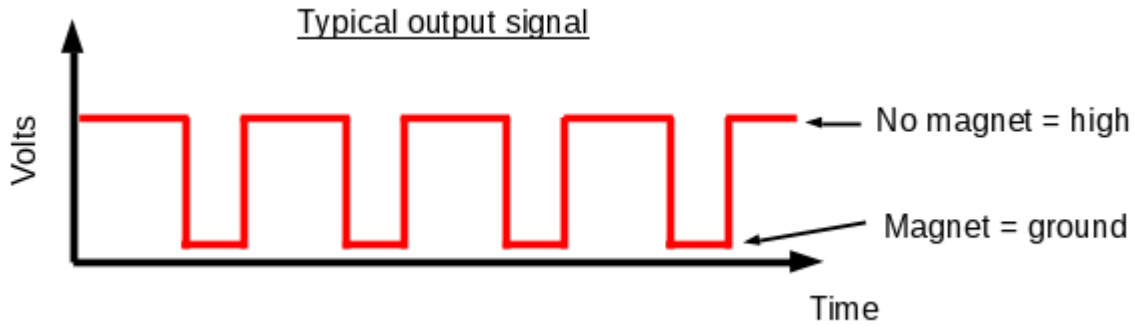

The hall sensor requires a supply voltage which is usually 12V from a fused 12V supply or 5V from the TPSREF output of the Megasquirt. The sensor is then grounded at the Megasquirt sensor ground and the signal wire connects to the Tach input.

Hall / geartooth / logic / optical sensor

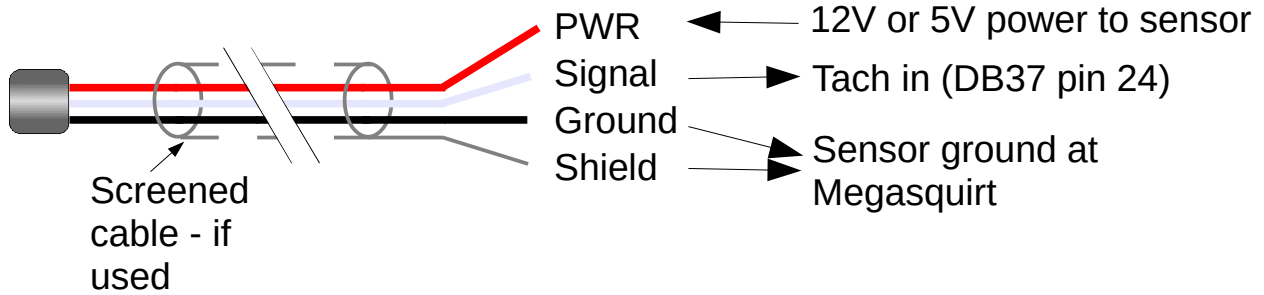

VR Input for logic input e.g. TFI, EDIS, GMDIS, LS1/24X, modules, hall sensor with built-in pullup

a) Solder a link between VRIN and TACHSELECT



b) Solder a wire between VrOUT and TSEL



c) With a small screwdriver, turn the pots, R52 and R56, about 12 turns anticlockwise (sometimes you may feel a "click" when the end position is reached, they can't be damaged by turning too far.)

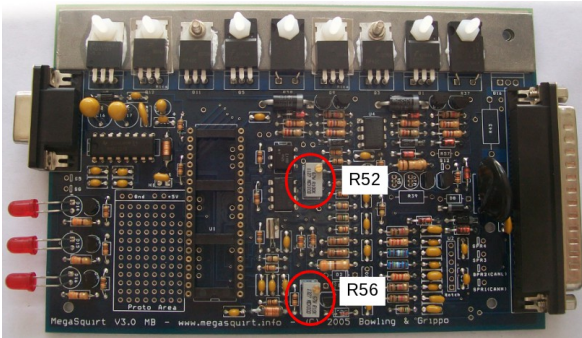

d) Turn R56 back about 6 turns clockwise.

Optionally, when adjusting R56, you can measure the voltage at the "top" of R54. You'll need the board powered up. Set your meter to volts, and connect the +ve probe to the top of R54 and the -ve probe to ground. Adjust R56 to get around 2.5V on your meter.

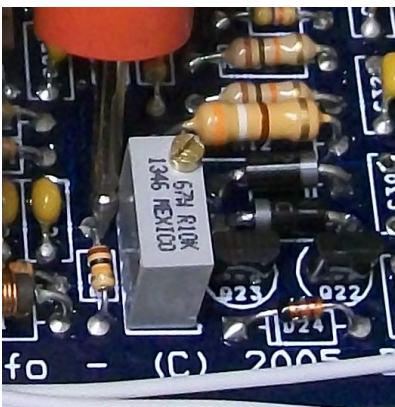

5.2.5 Gear-tooth sensor input



The gear-tooth sensor is a variant of the hall sensor - the key difference is that it has a magnet built into it and switches when close to steel, no external magnets are required. This makes them very easy to use. These are almost exclusively a three wire sensor. In CAS (crank angle sensor) units a multi-plug may be used to combine multiple sensors. The sensor itself acts like a switch to ground when close to steel.

Just like hall sensors, the gear-tooth sensor may be open-collector or have a built-in pull-up. Refer to sections 5.2.3 and 5.2.4 for more detail.

The image above shows the Honeywell 1GT101DC gear-tooth sensor, this works well for single tooth or half-moon cam wheels, but is not suitable for missing-tooth wheel installs.

5.2.6 GM LS 24X crank/cam sensors

The sensors used on the LS family of GM engines are designed to read the crank and cam triggers specific to

those engines. The 24X crank pattern uses a pair of adjacent toothed wheels and requires the specific GM sensor.

The 24X style black sensors use a 12V supply and operate like a hall sensor with a built-in pull-up - putting out a 0-5V logic signal as the teeth pass.

See section 5.2.4 for generic wiring.

24X (black) crank sensor

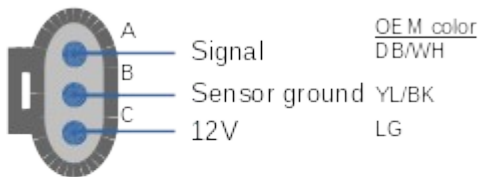

24X (black) cam sensor

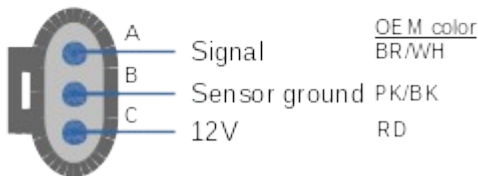

5.2.7 GM LS 58X crank/cam sensors

The sensors used on the LS family of GM engines are designed to read the crank and cam triggers specific to those engines. The 58X crank pattern uses a conventional single crank wheel.

The 58X style gray sensors use a 5V supply from TPSVREF and operate like an open-collector hall sensor as they require a pull-up resistor.

See section 5.2.3 for generic wiring.

58X (gray) crank sensor

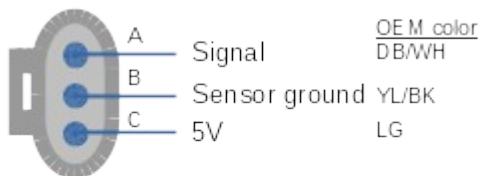

58X (gray) cam sensor

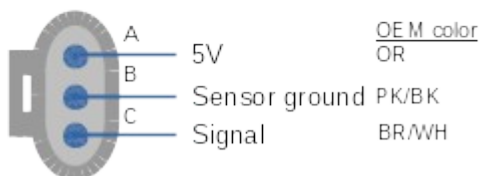

5.2.8 Optical sensor

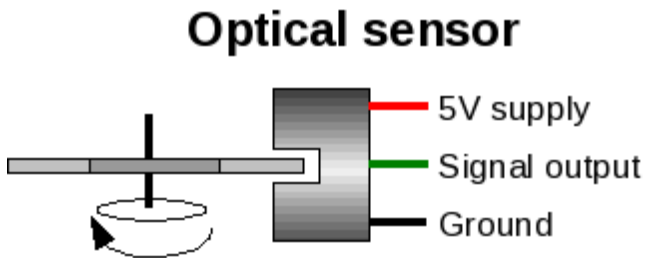

The optical sensor is another commonly used category of sensor. These are almost exclusively a three wire sensor. In CAS (crank angle sensor) units a multi-plug may be used to combine multiple sensors. The sensor itself acts like a switch to ground when light shines through the trigger disc. Optical sensors are commonly seen in distributors where vanes or shutters block the light causing the sensor to rapidly switch off and back on when light is present again. A pull-up resistor is almost certainly required.

See section 5.2.3 for wiring.

Note: One OEM application for optical sensors is the Mitsubishi/Nissan/Optispark CAS. Megasquirt-2 does not support the 360 slit "hi-res" tach input from these CASes, see the specific manual section for configuration details.

5.2.9 Distributor points input

NOTE: re-phasing a distributor can be quite awkward - installing a trigger-wheel for tach input is strongly recommended instead.

It is possible to convert a points distributor to give a tach input to Megasquirt and have control of your timing. In this case the points now only provide a tach signal and the Megasquirt is used to control the coil. Most conventional points distributors have a mechanical advance (weights) and a vacuum canister. In the original system these change the timing depending on engine RPM and load. Now that Megasquirt will be controlling the timing you will need to lock out these mechanisms in your distributor and likely change the phasing.

Set the engine to approx 10BTDC. Rotate the distributor so that the point are just opening when the engine rotates forwards.

Now set the engine to approx 25BTDC - the rotor arm needs to be pointing directly to a tower on the distributor cap.

You will likely need to make mechanical changes (cutting, bolting, welding) inside the distributor to achieve this.

With incorrect rotor arm phasing you will very likely end up with cross-firing to the wrong cylinder.

The low-tension side of the coil must be disconnected from the distributor and is now controlled by the Megasquirt (see ignition outputs section.)

The points are grounded within the distributor and the points terminal is connected to the Megasquirt tach input.

A pull-up resistor is required in the wiring harness or inside the Megasquirt.

Set mainboard as per section 5.2.3.

Points

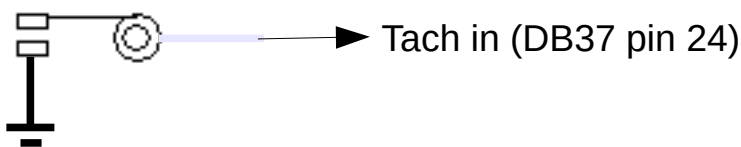

5.2.10 Combined Ignition module (TFI, EDIS, HEI, GMDIS)

Some ignition modules, particularly from the 1980s combine the tach input and coil driving ignition output within one module. All of them supply a simple square wave digital signal to the Megasquirt and should be connected to the Tach input.

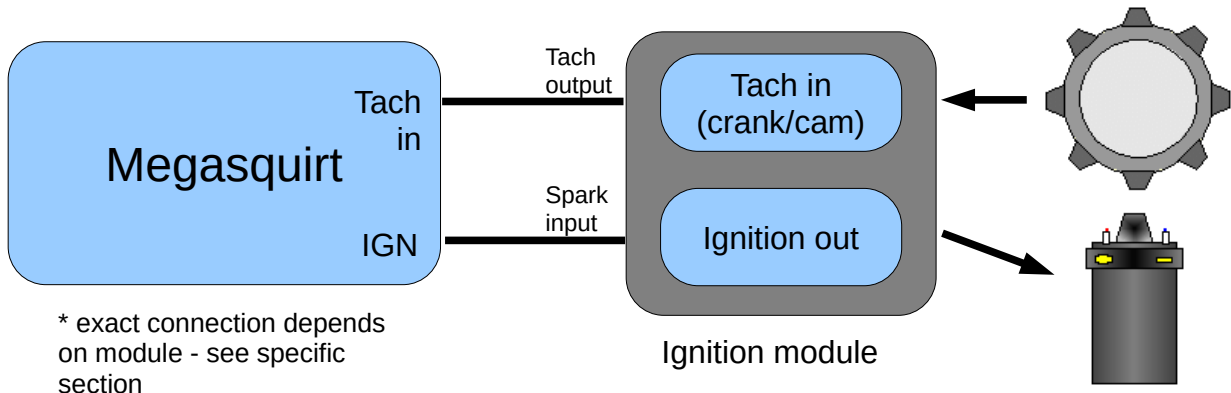

It is important to be aware that while Ford EDIS and GM DIS both have special toothed wheels, the module handles all the decoding and presents a signal to the Megasquirt that looks like a distributor input. With these two modules, the Megasquirt does not know or care how many teeth are actually on the wheel, so do not use the "toothed wheel" setting. This also means that normally you cannot use sequential fuel with these systems as no engine position information is available to the Megasquirt.

Full configuration details for these specific installs are covered in the section 6.

5.2.11 Nissan CAS

The Mitsubishi CASes used on many Nissans and GM LT1 Optispark use a dual optical pickup and a trigger disc with a high-resolution series of 360 outer slits and a low-resolution series of inner slots - one per cylinder.

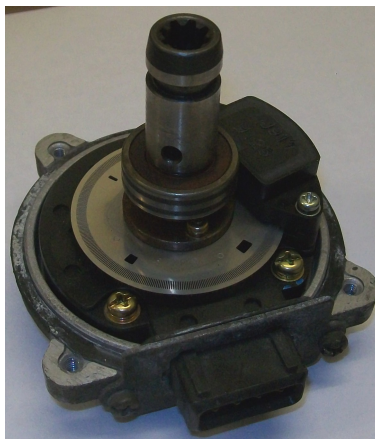

The Megasquirt-2 code does not support the high-resolution outer signal. The low-resolution inner signal can be used with a single coil and distributor in "Basic Trigger" mode.

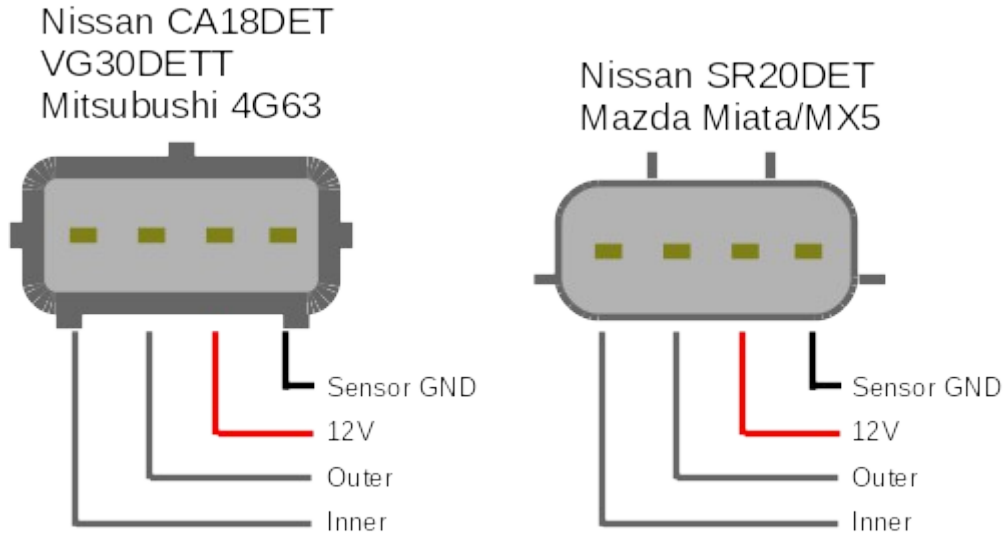

With the stock trigger disc, the high-resolution outer track is not used. The low-resolution inner track is connected to the Tach input.

Set the mainboard as per section 5.2.3

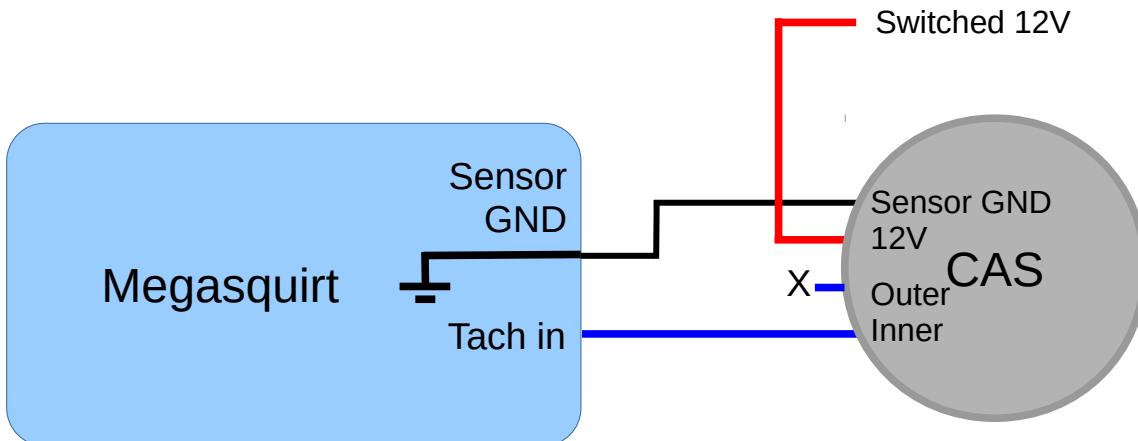

Typical settings:

Spark mode = Basic Trigger

Trigger angle/offset = Start at 10 deg - adjust while strobing timing.

Ignition input capture = ????

Number of coils = Single coil

5.2.12 4G63 / 6G72

Some other hall or optical CASes such as 4G63 (Miata) and 6G72 can be supported by special decoders for the trigger pattern.

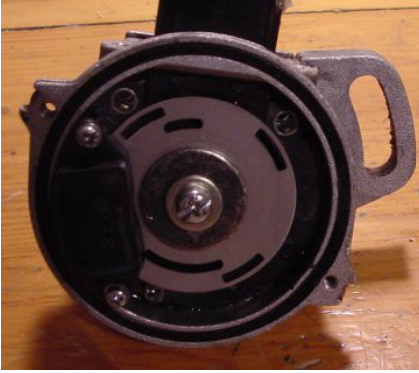

See sections 6.15 for 6G72 and 6.18 for 4G63

5.2.13 Mitsubishi CAS with aftermarket disc

As an alternative to the 360 slot CAS or low resolution 4G63, 6G72 patterns, many companies offer replacement trigger discs with standard patterns. When this kind of replacement trigger disc is installed the "Toothed Wheel" mode needs to be used - see section 6.9

5.2.14 Adding a cam sensor input

Many ignition configurations are supported using a single 'crank' tach input e.g. distributor, EDIS, wasted spark from a crank wheel etc. However, certain ignition combinations require two tach inputs 'crank' and 'cam'. e.g. coil-on-plug ignition, 4G63, 6G72 or some of the other OEM specific ignitions.

Internal modifications are required to add support for a cam sensor input on MS2V3.

An important technical note : some of the OEM specific decoders compare the crank and cam signal polarities, the main tach input inverts the incoming signal, so the added cam tach input must do the same. The suggested circuits here respect that requirement.

5.2.14.1 Adding a cam sensor input - VR/magnetic sensor

For the DIYer, the most straightforward circuit for the cam input is based on the LM1815N chip. (An alternative would replicate the crank circuit, but for the DIYer there are significantly more components.)

Build the following circuit in the proto area. The input pin chosen on the main DB37 connector is your choice.

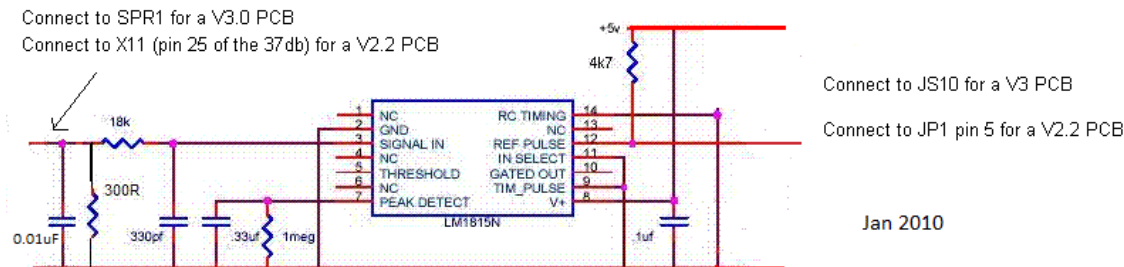

5.2.14.2 Adding a cam sensor input - hall sensor / optical sensor

This option uses the spare opto-isolator on the mainboard for the cam input and matches the polarity inversion of the VR/universal tach input.

This section is for open-collector sensors as covered in 5.2.3 that ground switch only.

a) The OptoIn pad should be connected to a spare pin on the main DB37 connector (e.g. SPR3)

- b) Connect OptoOut to JS10 (ensuring that nothing else is connected.)
- c) Jumper XG1 - XG2
- d) Check that R12 is a 390R to 470R resistor, replace if not.
- e) Install a 470R 1/4W resistor on the proto area to +5V.
- f) Jumper the other end of the 470R resistor to OptoIn (joining the jumper wire there.)
- g) Ensure that C30 is not fitted.

5.2.14.3 Adding a cam sensor input - hall or logic sensor

This option uses the spare opto-isolator on the mainboard for the cam input and matches the polarity inversion of the VR/universal tach input.

This section is for sensors as covered in 5.2.3 that put out a 0-5V signal.

- a) The OptoIn pad should be connected to a spare pin on the main DB37 connector (e.g. SPR3)
- b) Connect OptoOut to JS10 (ensuring that nothing else is connected.)
- c) Jumper XG1 - XG2
- d) Check that R12 is a 390R to 470R resistor, replace if not.
- e) -not required-
- f) -not required-
- g) Ensure that C30 is not fitted.

5.2.14.4 Adding a cam sensor input - ground switching

This option uses the spare opto-isolator on the mainboard for the cam input, with the sensor in ground-switching mode. This will usually give more reliable operation, but it does not match the polarity inversion of the VR/universal tach input - this is not a problem in "Toothed wheel" mode.

- a) The OptoIn pad should be connected to 5V in the proto area.
- b) Connect OptoOut to JS10 (ensuring that nothing else is connected.)
- c) Jumper XG1 to a spare pin on the main DB37 connector (e.g. SPR3) - this is your cam input.
- d) Check that R12 is a 390R to 470R resistor, replace if not.
- g) Ensure that C30 is not fitted.
- h) Fit or jumper D1 and D2

5.3 Ignition outputs

The MS2/V3.0 has provision for a single high-current ignition output as standard. Up to six ignition outputs are available with suitable internal modifications.

On regular ignition installs, the ignition outputs must be connected in firing order sequence.

e.g. a 4-cyl engine with coil-on-plug and a 1-3-4-2 firing order would connect A=1, B=3, C=4, D=2

Rotary engines are wired differently - refer to the specific section.

 Double check your Spark Output setting - this is a critical !
Setting it incorrectly could result in melted coils.

 It is strongly advised that ignition coils are powered from the fuel-pump relay. This ensures that the coils can only be powered when the engine is running.

The diagram below shows the signal source for each of the ignition outputs - they all require an interface circuit - do not connect these directly!

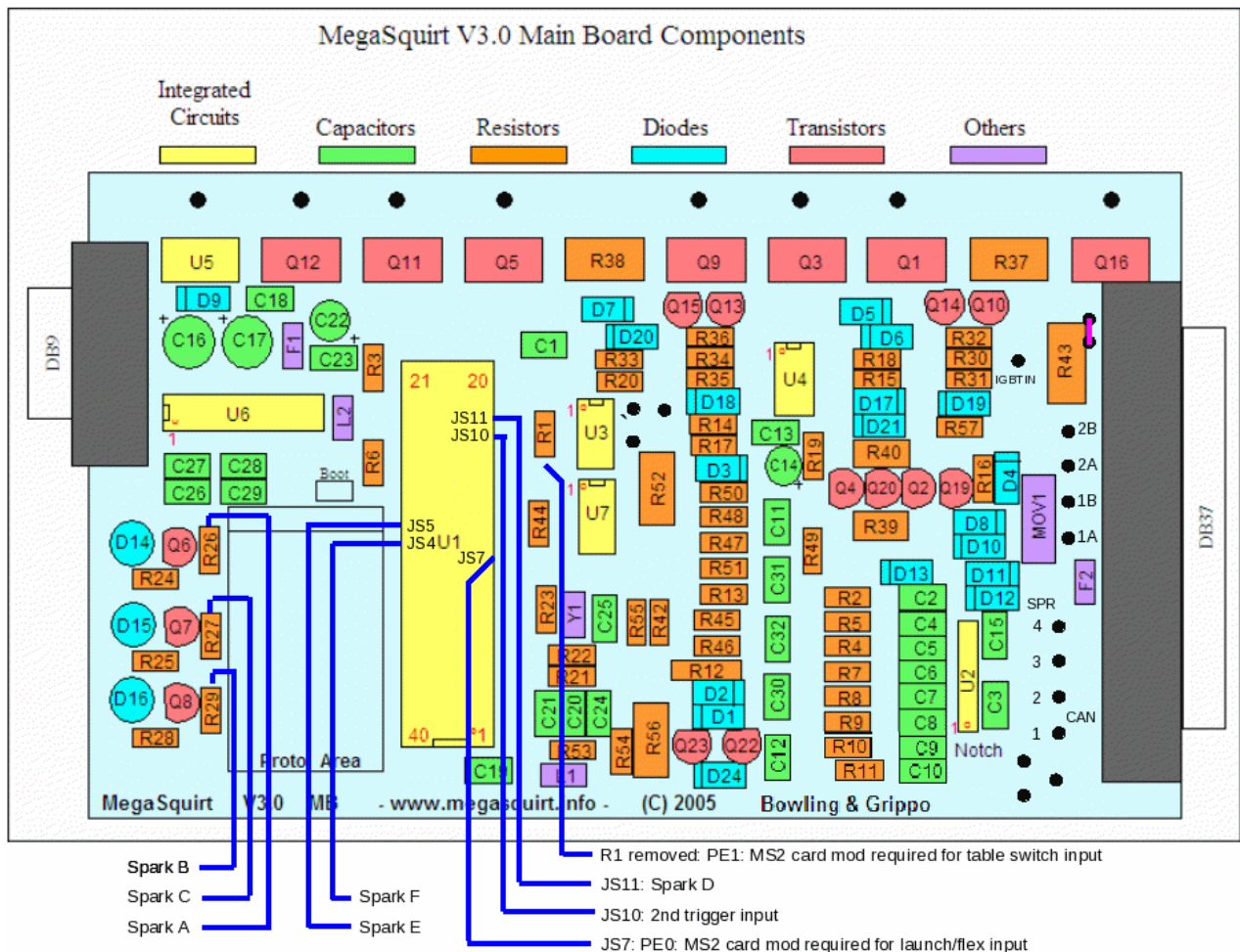

Output	Resistor	CPU pin
Spark A	Top of R26	7
Spark B	Top of R29	8
Spark C	Top of R27	9
Spark D	JS11	18
Spark E	JS5	29
Spark F	JS4	30

5.3.1 Building ignition outputs

5.3.1.1 High current output (one)

This provides a single high-current ignition output suitable for directly driving one inductive coil.

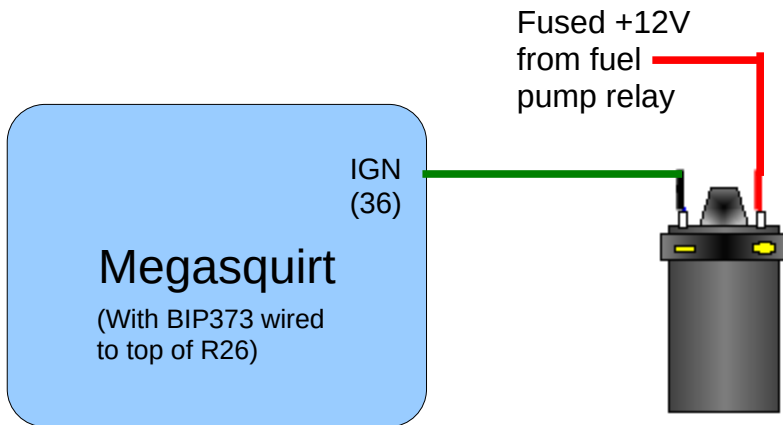

Internally, the follow is required:

- BIP373 (marked as 30115) needs to be installed in Q16 with a mica insulator.
- Jumper IGBTOUT-IGN.
- Connect a 330R 1/4W resistor between IGBTin and the top of R26.
- Ensure R57 is absent.
- Ensure R43 is fitted or jumpered.

Typical settings

Spark Output = Going High

Dwell Type = Standard Dwell

Dwell ~ 3ms for a standard coil

5.3.1.2 High current output (additional)

Additional BIP373 drivers can be installed inside the Megasquirt case. The simplest way is to buy a second heatsink bar and install it above the existing one. Extra BIP373 can be bolted on with the correct mica insulator.

The high current ignition outputs can be routed through a spare pin on the DB37 connector or through an additional connector. If using spare pins on the DB37 be sure that the board traces are thick enough. e.g. SPR1,2,3,4 have thin traces from the pads to the connector - these need a jumper wire in parallel. (A spare leg from a resistor will do the job.)

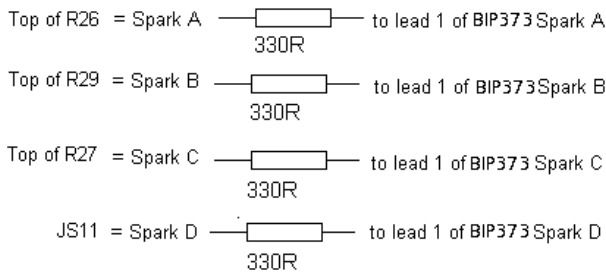

Spark A + B needed for 4cyl wasted spark
 Spark A + B + C needed for 6cyl wasted spark
 Spark A + B + C + D needed for 8cyl wasted spark

Note: The 330R base resistor is preferred, but if two VB921 are run from one spark output, you need to use 680R on each instead to avoid overloading the MS2 card

**Note:
 This db15 connector is NOT the V3.57 connector, it is an additional connector for the V3.0 PCB!!!**

Lead 2 of BIP373s go to the DB15 connector

- Lead2 for Spark A = pins 1+2
- Lead2 for Spark B = pins 3+4
- Lead2 for Spark C = pins 5+6
- Lead2 for Spark D = pins 7+8

Link all pin 3's of the BIP373 together like this connect to pins 9 and 10 of the DB15

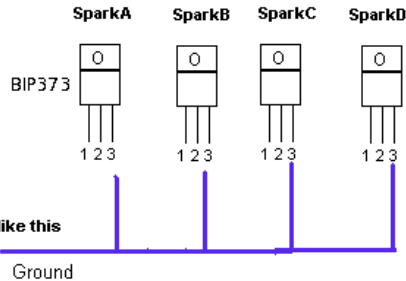

Schematic Diagram

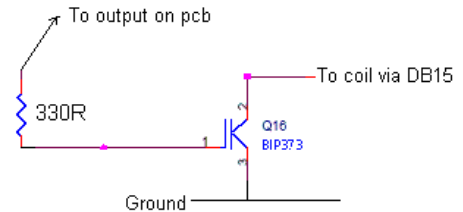

5.3.1.3 Logic spark outputs - FET driver method

This circuit is suitable for driving LS1 type coils and many other logic coils including VW COPs with a low input impedance. See also section 5.3.1.4 for a simple method.

With this wiring the Spark output must be set to "Going High".

Pros:

- Can drive most logic coils including low resistance VAG COPs.
- Coils do not receive a spurious signal pulse at power on.
- Uses standard "Going High" setting.

Cons:

- Can be more difficult to install.
- Requires a few more additional components.

Build the following circuit(s) in the proto area or on prototype board.

Parts required for two channels:

- TC4427AEPA
- 2x 15R 1/8W resistors

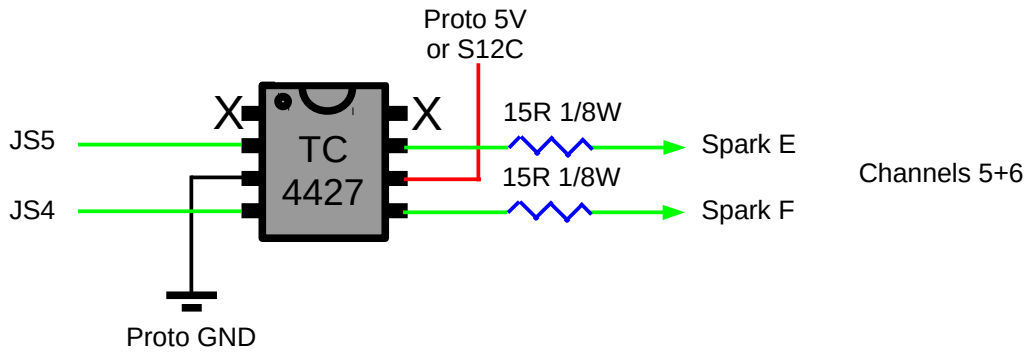
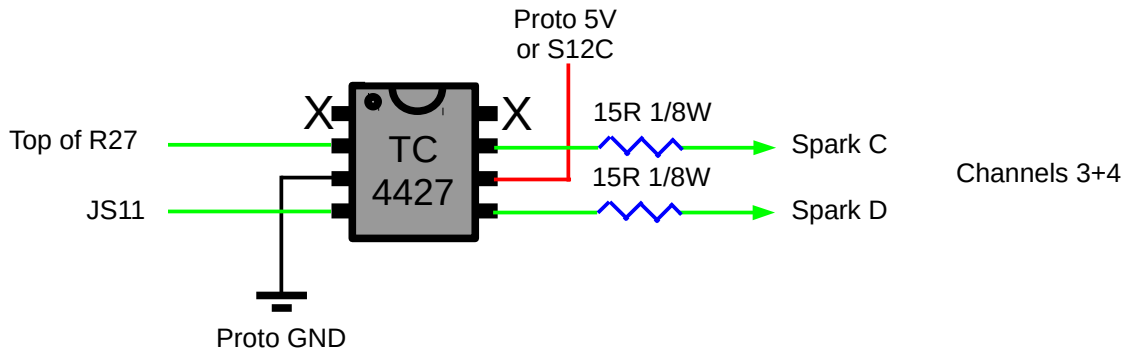
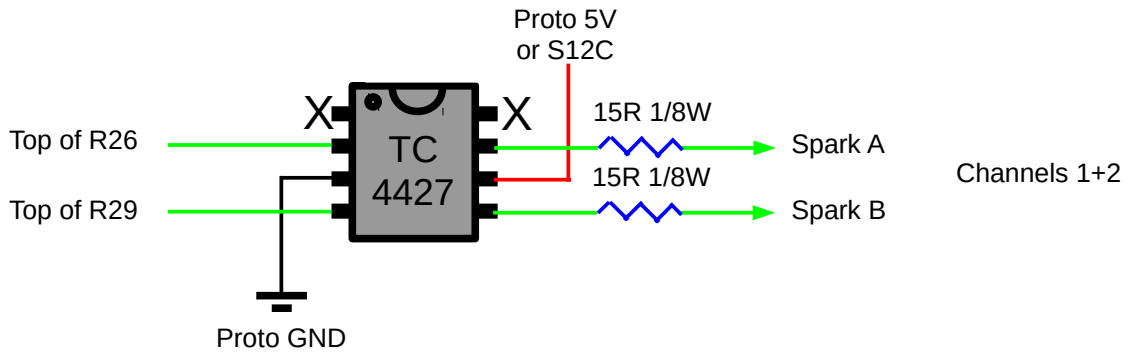

The Spark A,B,C etc. outputs need to be jumpered to the connector of your choice.

5.3.1.4 Logic spark outputs - resistor method

This section shows a simple method for wiring logic outputs. (This circuit is commonly shown in documentation prior to July 2014.)

With this wiring the Spark output must be set to "Going Low".

Pros:

- Simple to wire in.
- No additional components required for Spark A,B,C.

Cons:

- Coils receive a spurious pulse at power on.
- Cannot drive some VAG COPs.

The diagram here shows the connections required for four channels (e.g. 4cyl COP or 8cyl wasted spark.) If 5th and 6th logic channels are required, build additional transistor circuits with the inputs JS5 and JS4 and route the output from the circuits to spare output pins of your choice.

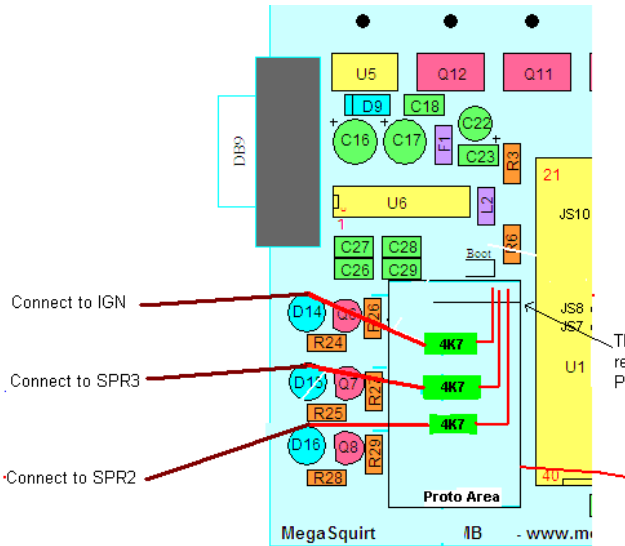

Add 4k7 resistor from the -ve side of D14 to the +5V on the proto area. Run a wire from the neg of D14 to IGN

Add another 4k7 resistor from the -ve side of D16 to the +5V on the proto area. Run a wire from the neg of D16 to SPR2

Add another 4k7 resistor from the -ve side of D15 to the +5V on the proto area. Run a wire from the neg of D15 to SPR3

Build a transistor circuit using a 2N3904 (or a 2N2222A) and a 1K resistor and a 4K7 resistor on the proto area for Spark D output

Connect to IGN
Connect to SPR3
Connect to SPR2

This side of all three 4K7 resistors goes to 5V on Proto Area

V3 PCB ONLY

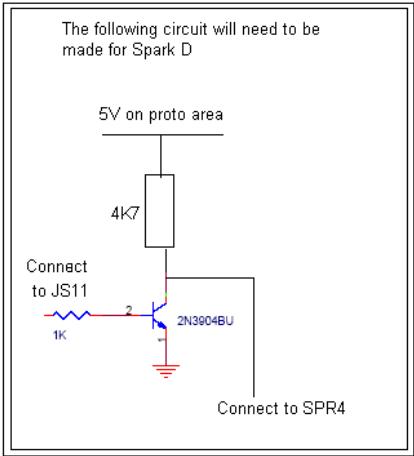
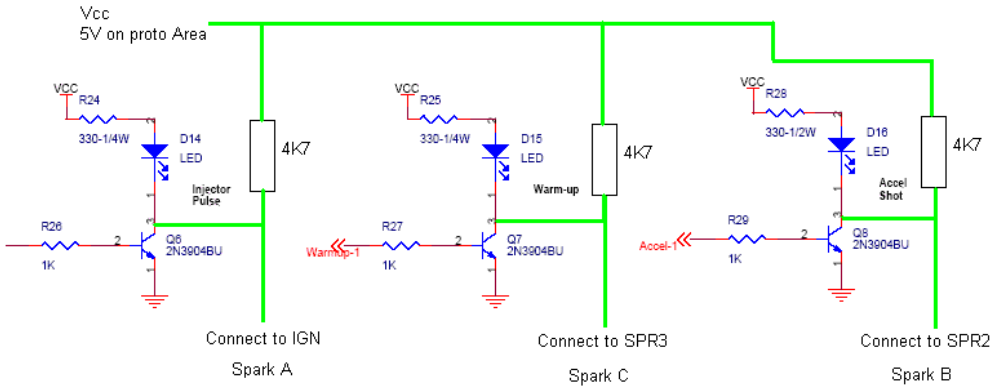

5.3.1.5 Optional DB15 connector for spark outputs

When many additional spark outputs are used and there are not enough free pins on the main connector it can be necessary to add an additional connector. Below is a suggested pin arrangement.

This connector can be used for high current outputs as shown in 5.3.1.2 or low current logic outputs as shown in 5.3.1.3.

For high-current outputs, the ground pins shown on the connector are connected internally to the grounds on the BIP373.

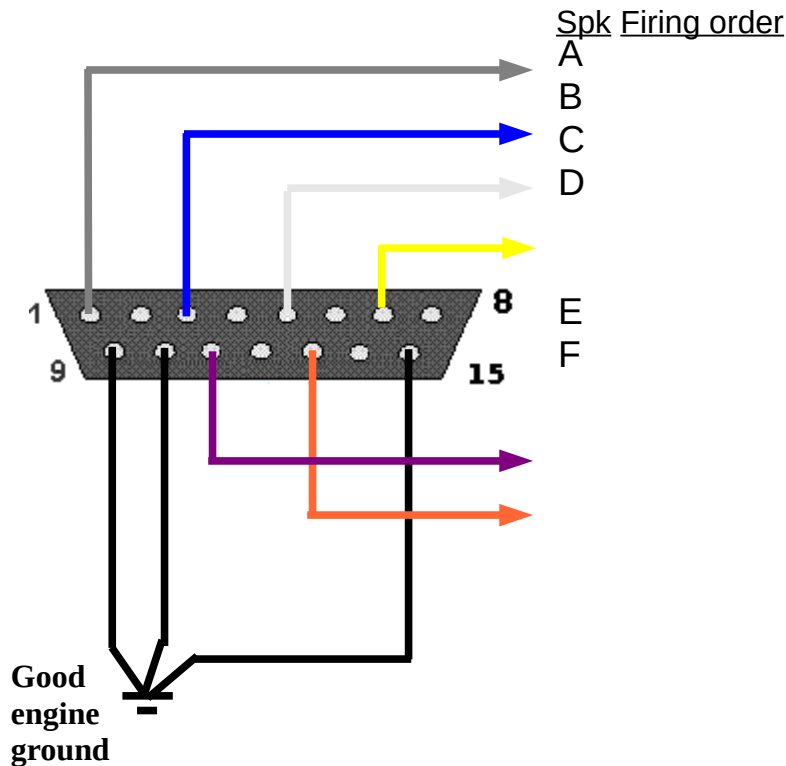

5.3.2 Logic coils

These coils can directly accept the 0-5V logic level signal from the Megasquirt. They contain an ignition driver and a coil within the package.



LS1 (left), LS2 middle), Truck (right) coils

LS1 Coil

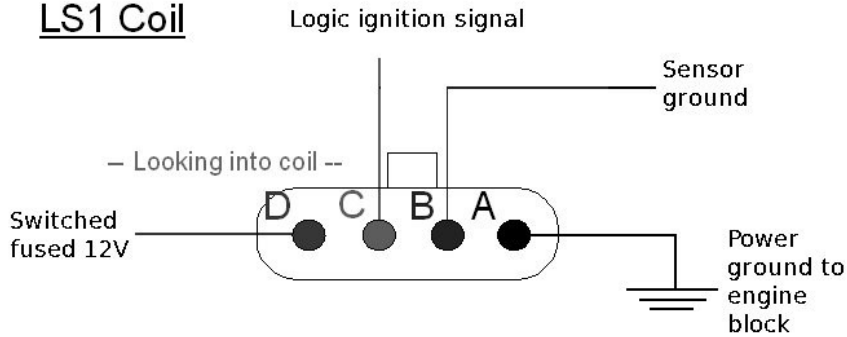

A dwell figure of 3.5ms is advised for LS1 coils.(was 4.5)

Note that some coils have a built-in over-dwell protection feature. If given too much dwell the coil will automatically spark. This can give a dangerous advanced spark. Be sure to strobe your timing at high revs to ensure this is not happening.

Set the Spark Output to Going High. Build circuit in 5.3.1.3

LS2 Coil

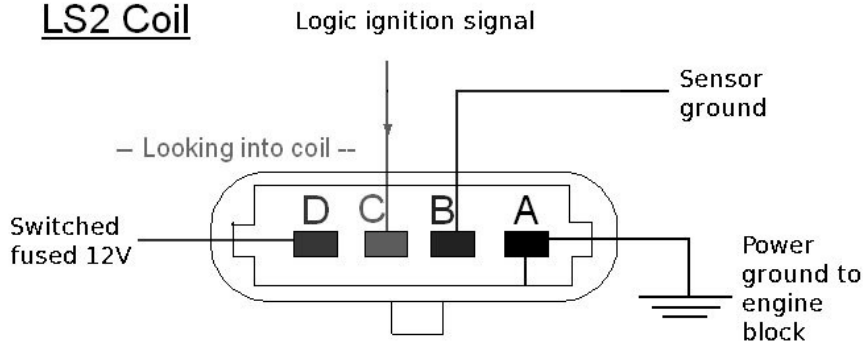

A dwell figure of 3.5ms is advised for LS2 coils. (was 4.5)

Note that some coils have a built-in over-dwell protection feature. If given too much dwell the coil will automatically spark. This can give a dangerous advanced spark. Be sure to strobe your timing at high revs to ensure this is not happening.

Set the Spark Output to Going High. Build circuit in 5.3.1.3

D585 truck coil

	<p>Pin-out</p> <p>A = Power ground to engine block B = Signal ground (connect to sensor ground) C = Spark input signal D = 12V supply</p> <p>Common colors: A = black B = brown C = varies per coil</p>
--	--

	D = pink
--	----------

A dwell figure of 3.5ms is advised for truck coils.

Note that some coils have a built-in over-dwell protection feature. If given too much dwell the coil will automatically spark. This can give a dangerous advanced spark. Be sure to strobe your timing at high revs to ensure this is not happening.

Set the Spark Output to Going High. Build circuit in 5.3.1.3

LS coilpack multi-plug

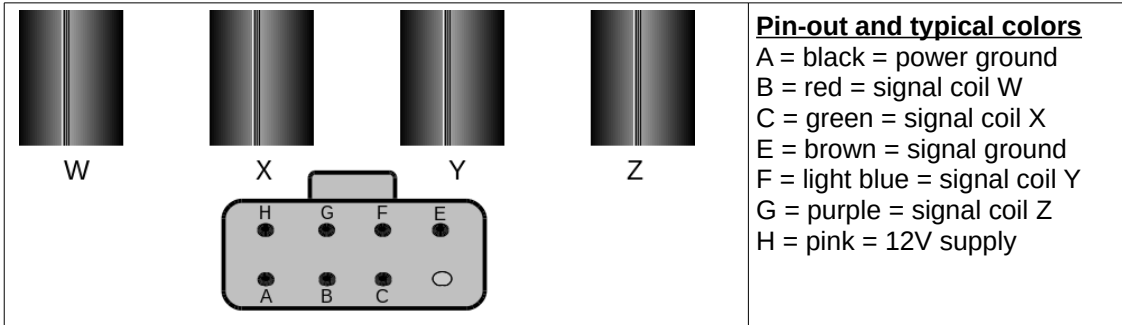

General layout for 4-cyl coil-on-plug using LS coils

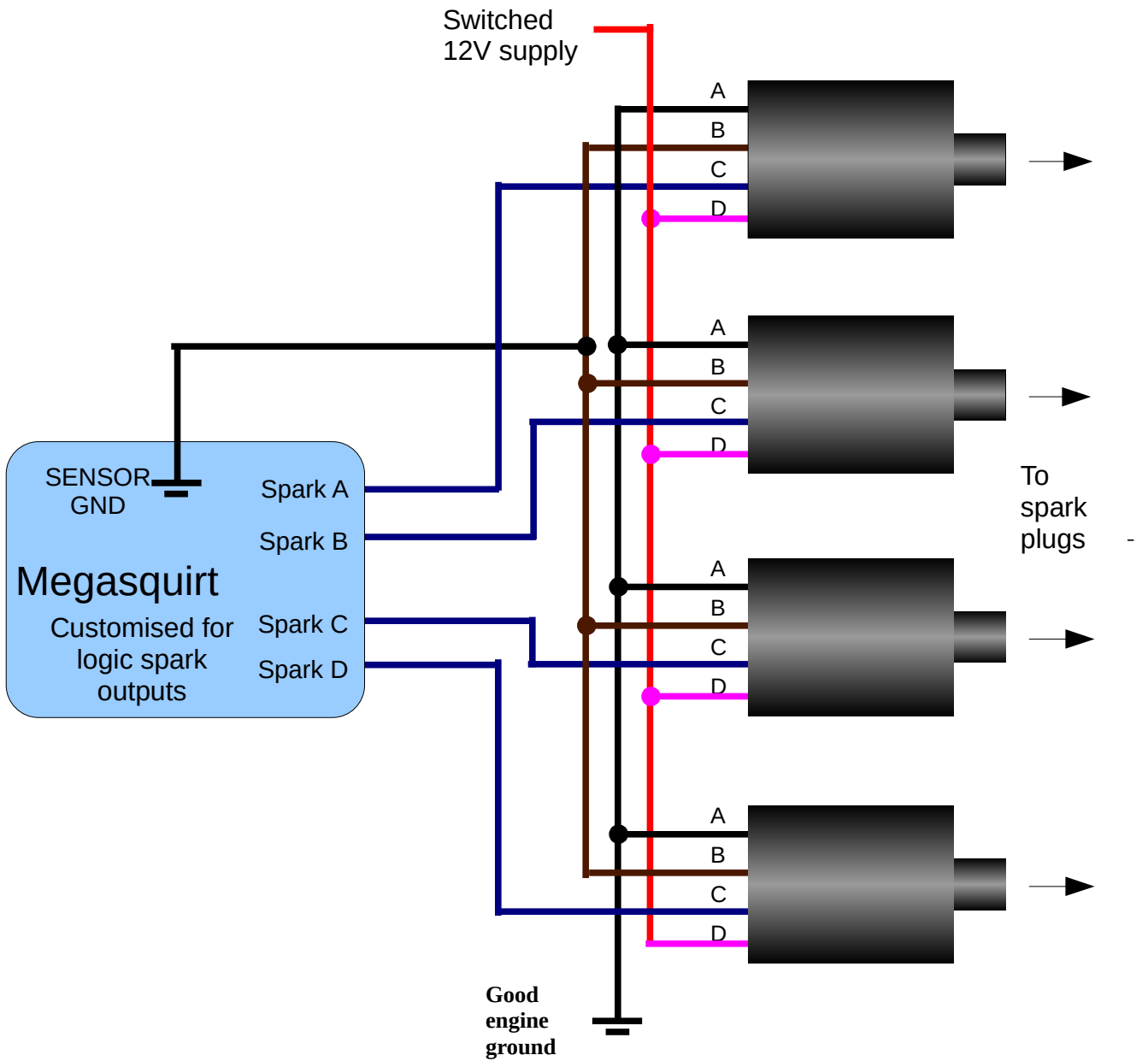

Set the Spark Output to Going High. Build circuit in 5.3.1.3

IGN1A logic coil



- A - Ignition signal from Megasquirt
 - B - Logic ground, connect to Megasquirt sensor ground
 - C - Spark wire ground, connect to cylinder head
 - D - Power ground, connect to battery negative
 - E - 12 volt power (switched and fused)
- Set the Spark Output to Going High. Build circuit in 5.3.1.3

This is a high energy aftermarket logic coil available from DIYautotune.com.

0 004- 402 001 - single logic coil



Pin-out

- 1 = Power Ground (Brown)
 - 2 = Spark input signal 1 (Black/Red)
 - 3 = 12V supply (Black)
- Set the Spark Output to Going High. Build circuit in 5.3.1.3

Fitted to many VAG vehicles including 2.0 litre mk3 Golfs 1993-1999. Designed to be used as a single coil with a distributor.

Intermotor 12916

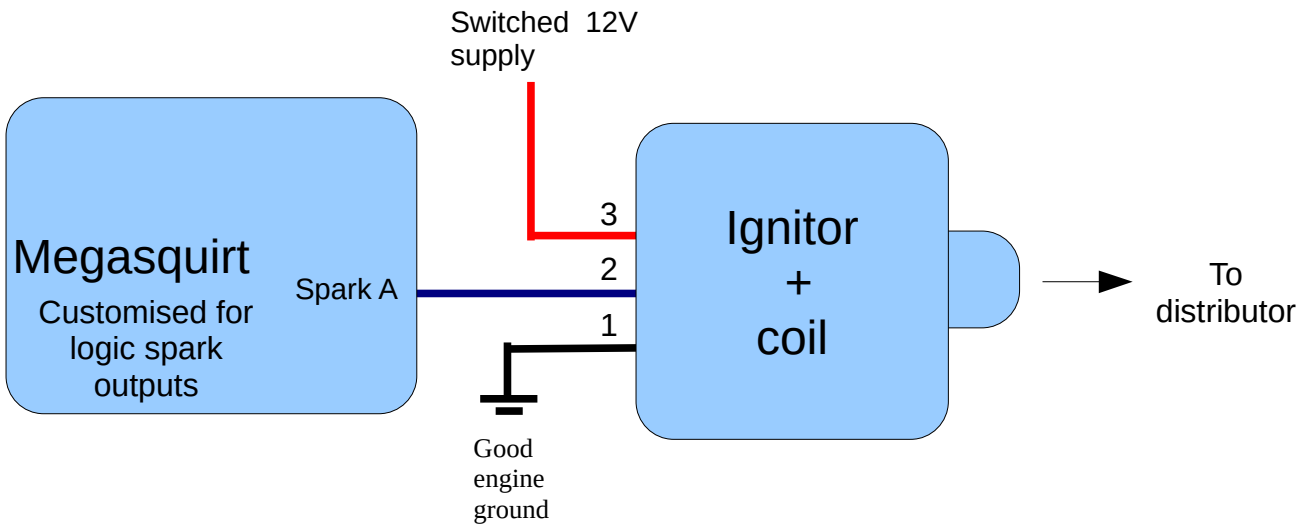

032 905 106B - 4 tower wasted spark logic coil



Pin-out

- 1 = Spark input signal 1
- 2 = 12V supply
- 3 = Spark input signal 2
- 4 = Power Ground

Set the Spark Output to Going High. Build circuit in 5.3.1.3

The connector is 1J0 973 724

This cost effective OEM logic wasted coil has a built-in ignitor.

Fitted to many VAG vehicles including 1.6 litre mk4 Golfs.

Intermotor 12919

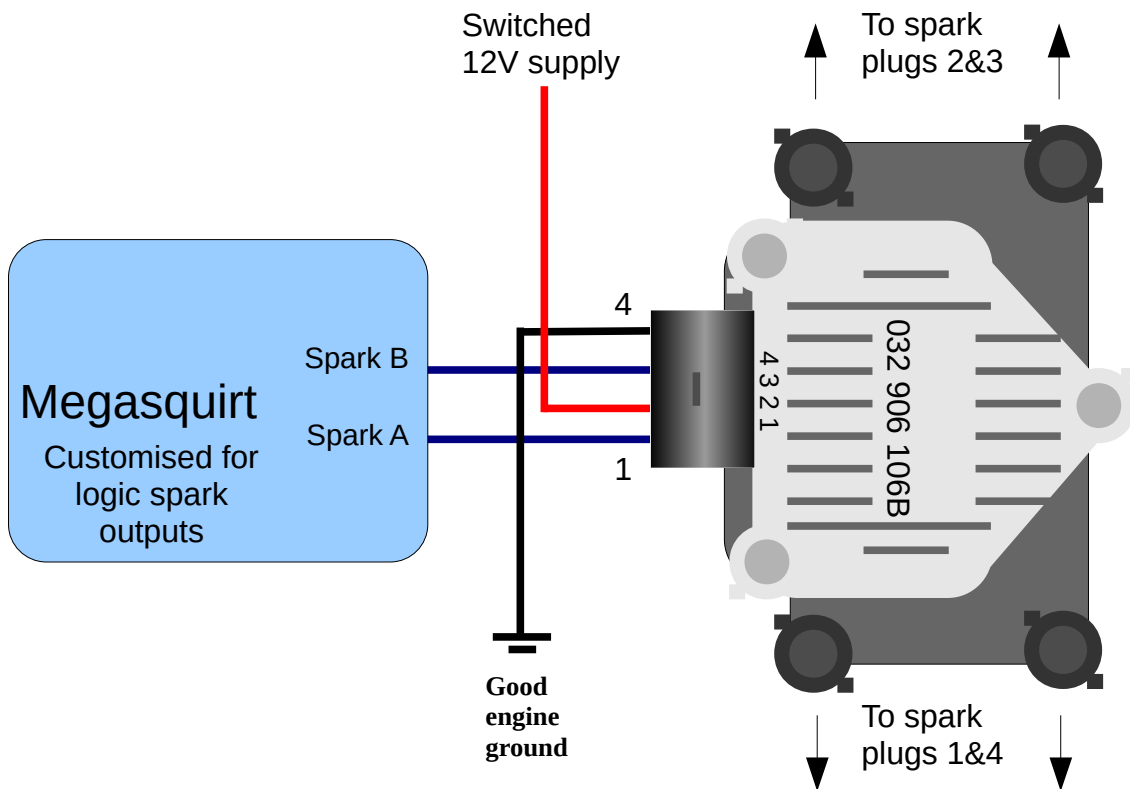

06A905097 - 4 way logic coil



4 way logic coil from VW Golf / Jetta, Skoda Octavia

Uses part numbers 0040102029, 06A905097, 06A905104, ZSE029

The connector is a polarised Bosch Kompact 6 way. 1J0973726 - 6 Way Sealed Female Connector. The contacts are 2.8 mm

Set the Spark Output to Going High.

Build circuit in 5.3.1.3

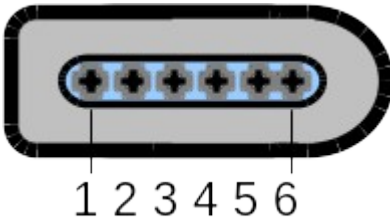

Pin-out

- 1 = Power Ground
- 2 = Spark input signal 1
- 3 = Spark input signal 2
- 4 = Spark input signal 3
- 5 = Spark input signal 4
- 6 = 12V supply

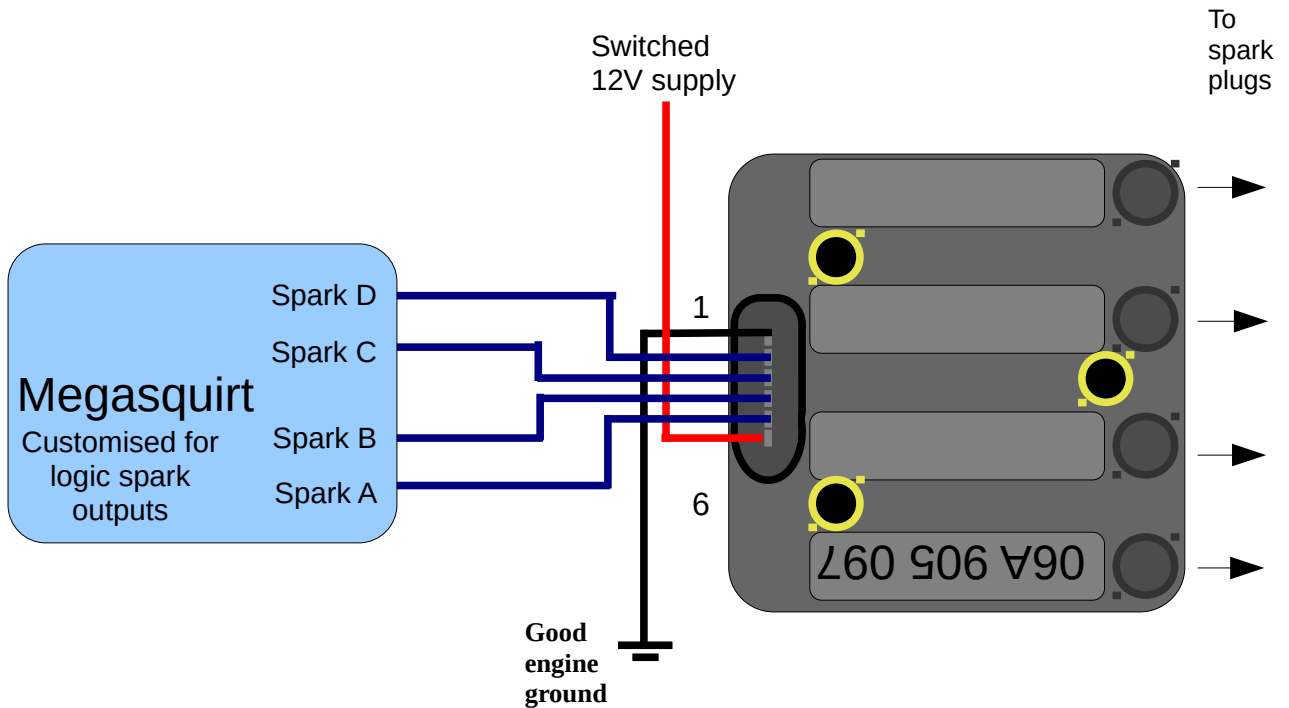

06B 905 115 - 4 wire logic COP



VAG P/N 06B 905 115 COPs: used on VW 1.8t and may other VAG cars.

Pin 1: Connects to Pin 1 on all other coils and then to +12v ignition feed (or fuel pump relay)

Pin 2: Signal ground (connect to engine block)

Pin 3: Spark Signal from Megasquirt

Pin 4: Power ground (connect to engine block)

Earlier than 2001 coils, PN - 06B 905 115, 06B 905 115 rev B and E.

These have an input resistance of ~1k and should work OK with the Megasquirt outputs.

Cranking dwell = 4.0ms Running dwell= 3.0ms

Set the Spark Output to Going High

Build circuit in 5.3.1.3

Later than 2001 coils, PN 06B 905 115 rev L and R have a low input resistance. The circuit in 5.3.1.3 can drive these fine (other circuits may not work correctly.)

Aside from these specific examples, there are many generic 3, 4, 5 wire COPs that can be used with the Megasquirt.

Before using an "unknown" coil it is necessary to check the resistance to ground on the input.

Using a multimeter set to resistance, check between the Spark Signal Input and Signal Ground.

If you have a reading of say ~1k then the Megasquirt outputs can be used directly.

Logic level 3 wire

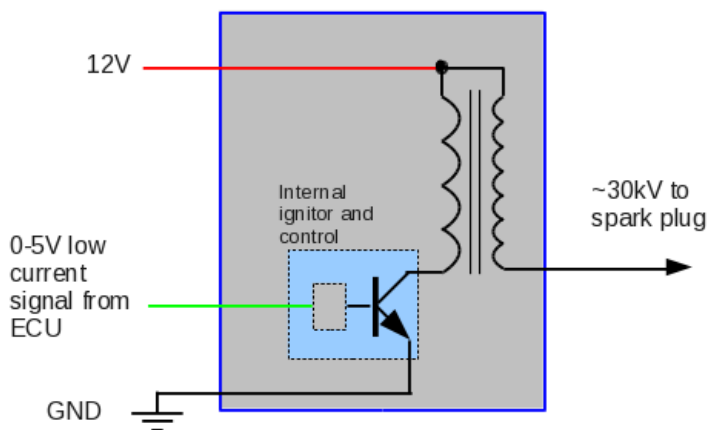

3-wire COPs are ambiguous, many are high-current (needing an ignitor), some may be logic level with a built in driver. Perform a resistance check on the signal input to confirm. High current will have an input resistance to 12V of a few ohms only.

Logic level 4 wire

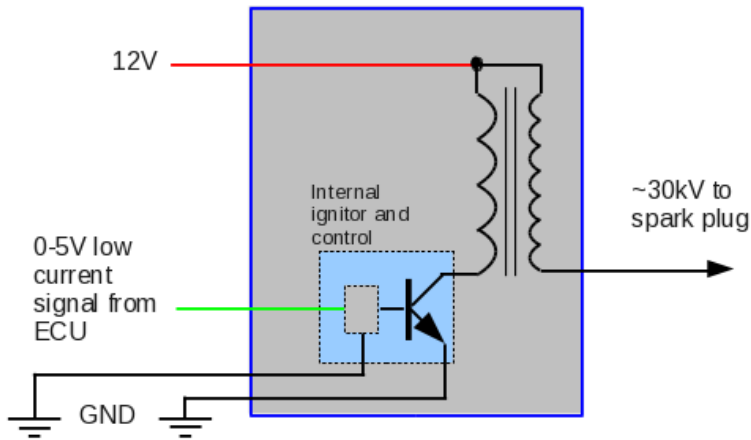

COPs with 4 or 5 wires have a built in amplifier (ignitor) so they require that you build the circuit in 5.3.1.3 and set the Spark Output to Going High.

5.3.3 Amplifiers (ignitor, power transistor, ignition module)

An ignition amplifier module takes a 5V logic signal from the Megasquirt and drives a high-current ignition coil. This can be advantageous to keep ignition noise outside of the Megasquirt, or your engine may already have one.

There are many different modules available on the market with 1, 2, 4 ignition channels.



Bosch style 1, 2, 4 channel ignitors and Quadspark 4 channel ignitor.

Bosch 0 227 100 124

Cross references Intermotor 15015.

This single channel module can be used to drive a single high-current coil. Dwell is controlled by the Megasquirt. Set the Spark Output to Going High. Build circuit in 5.3.1.3

Pin-out

- 1 = Coil negative output
- 2 = Power Ground
- 3 = Input screen (if used)
- 4 = 12V supply

5 = Spark input signal

6 = NC

(7 = NC)

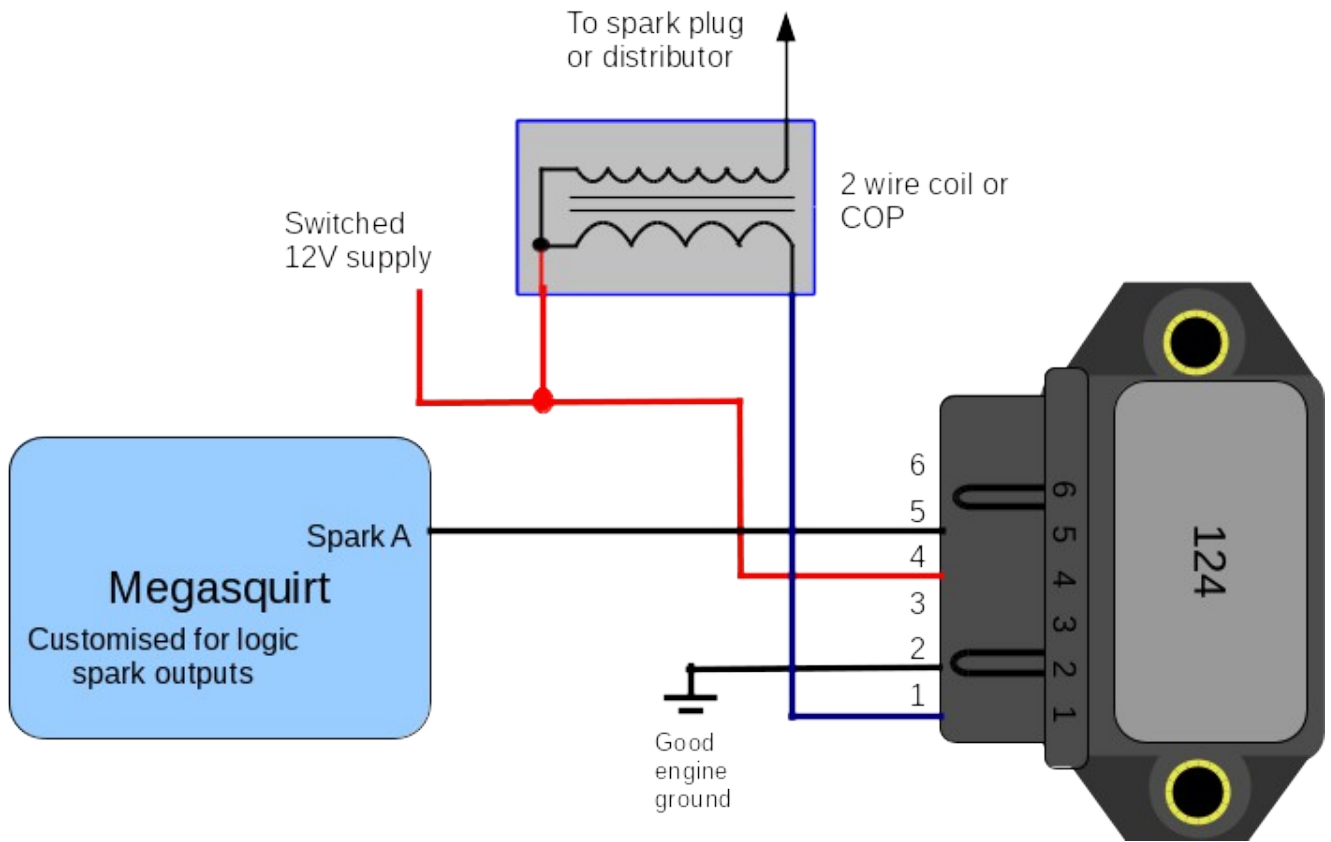

Bosch 0 2227 100 137

This is very similar to the 124 but the spark input signal is on pin 6.

Bosch 0 227 100 200

Cross references Intermotor 15867.

This dual channel module can be used to drive a high-current wasted spark coil-pack for full spark control on a four-cylinder engine, or a pair of COPs on a two-cylinder engine. Dwell is controlled by the Megasquirt.

Set the Spark Output to Going High. Build circuit in 5.3.1.3

Pin-out

1 = Coil negative output 1

2 = Spark input signal 1

3 = NC

4 = Power Ground

5 = NC

6 = Coil negative output 2

7 = Spark input signal 2

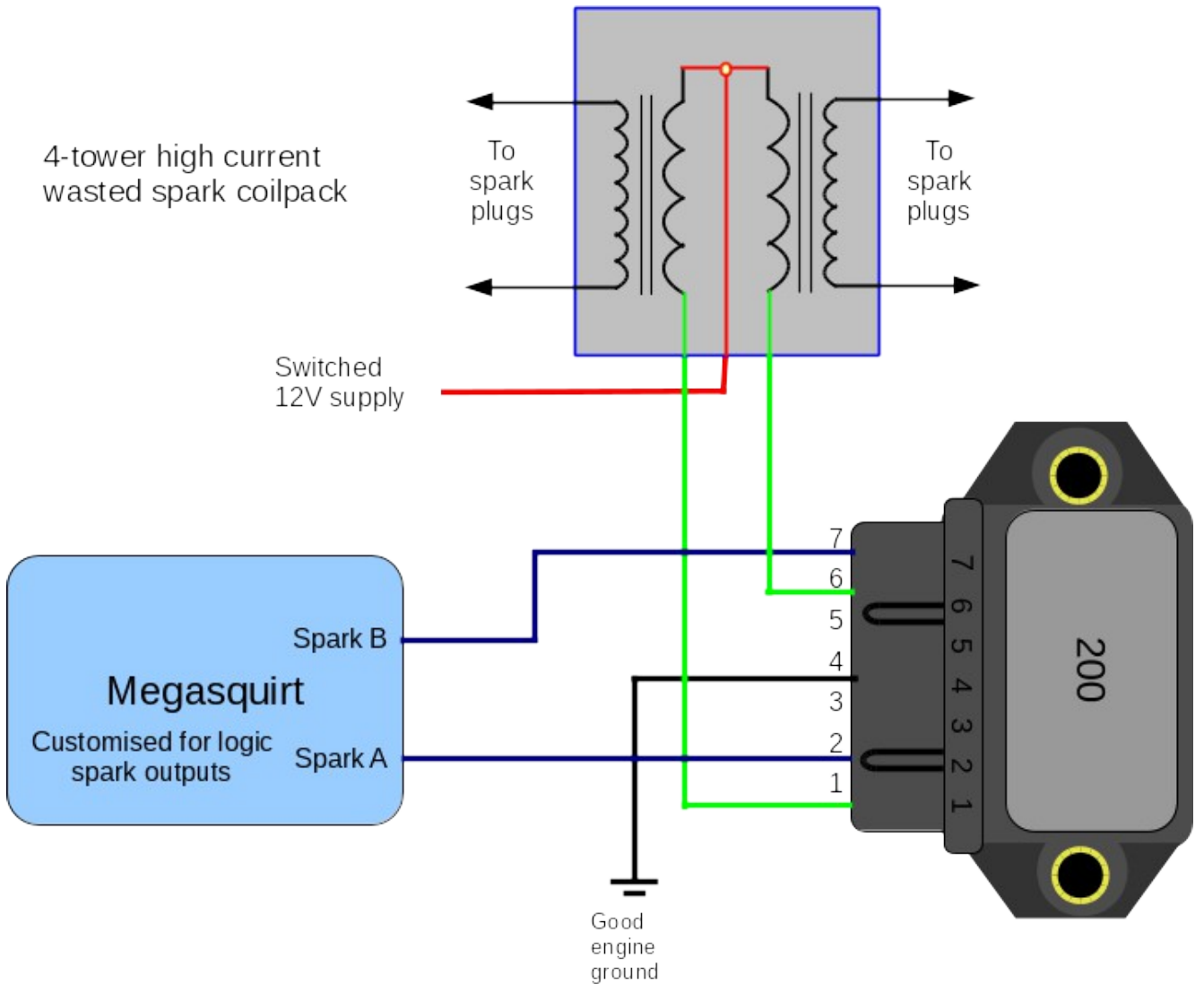

Bosch 0 227 100 211

Cross references Intermotor 15857. Typically used on VW Golf 1.8t yr 2000.

This four channel module is typically used to drive four COPs on a four-cylinder engine, it could also be used to drive a pair of high-current wasted spark coil-packs for full spark control on an eight cylinder engine. Dwell is controlled by the Megasquirt.

Set the Spark Output to Going High. Build circuit in 5.3.1.3

Pin-out (5 pin)

- 1 = Spark input signal 1
- 2 = Spark input signal 2
- 3 = Power Ground
- 4 = Spark input signal 3
- 5 = Spark input signal 4

Pin-out (4 pin)

- 1 = Coil negative output 4
- 2 = Coil negative output 3
- 3 = Coil negative output 2
- 4 = Coil negative output 1

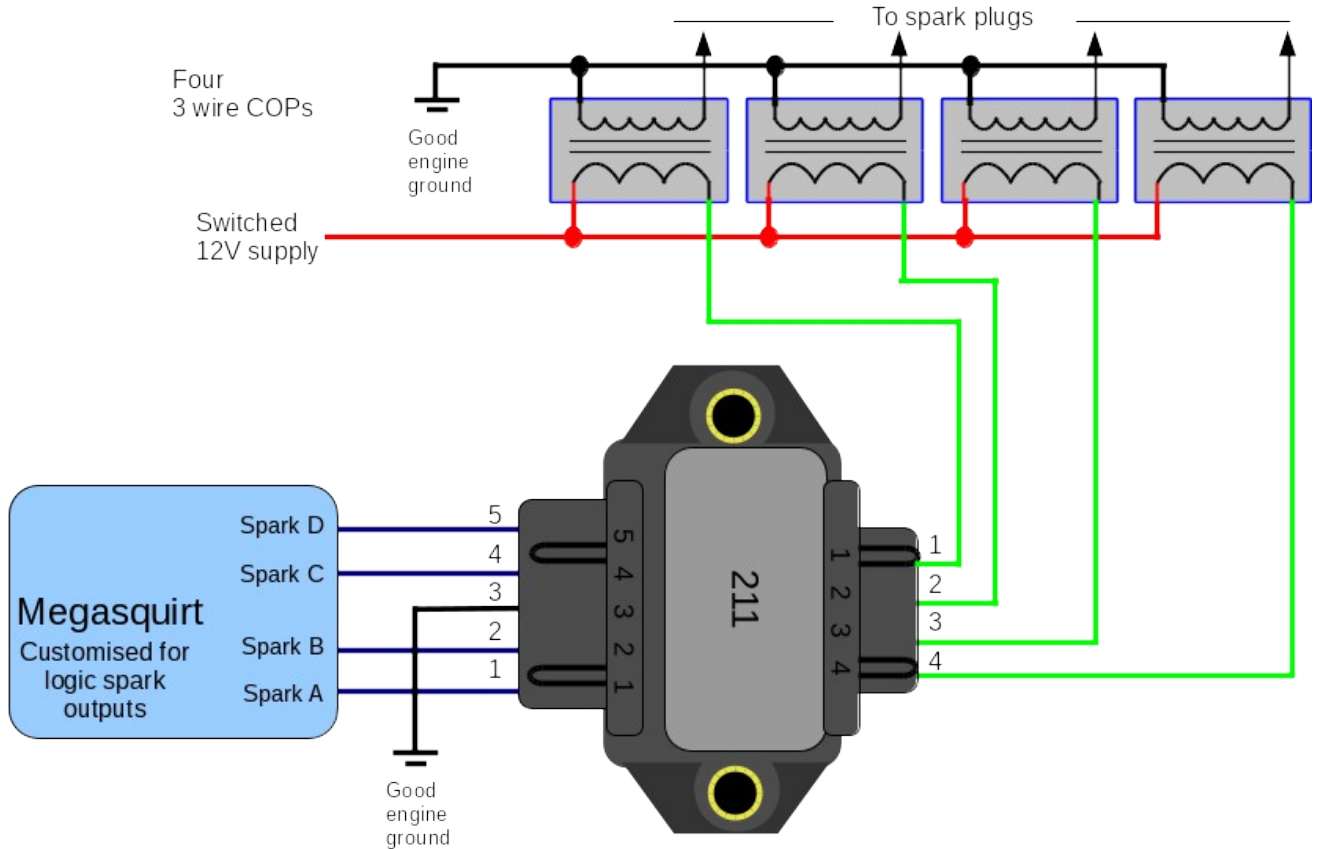

Quadspark



This aftermarket four channel module operates similarly to the Bosch 211, but is typically more cost effective.

Pin-out	Thickness	Function
Yellow	20 gauge	Spark Input A (from Megasquirt)
White	16 gauge	Spark Output A (to coil negative)
Orange	20 gauge	Spark Input B (from Megasquirt)
Pink	16 gauge	Spark Output B (to coil negative)
Dark green	20 gauge	Spark Input C (from Megasquirt)
Light Green	16 gauge	Spark Output C (to coil negative)
Blue	20 gauge	Spark Input D (from Megasquirt)

Violet 16 gauge Spark Output D (to coil negative)
 Black 4 x 14 gauge Ground (to engine block or cylinder head)

Recommended - build circuit in 5.3.1.3. Set the Spark Output to Going High.

The wiring in 5.3.1.4 is not recommended.

As an alternative, install 330R resistors in the prototype area. Use a jumper wire to connect one end of the resistor to the CPU spark signal and a second jumper wire to the chosen DB37 connector pin. Set the Spark Output to Going High.

Output	Resistor in	Resistor out
Spark A	Top of R26	IGN
Spark B	Top of R29	your choice
Spark C	Top of R27	your choice
Spark D	JS11	your choice
Spark E	JS4	your choice
Spark F	JS5	your choice

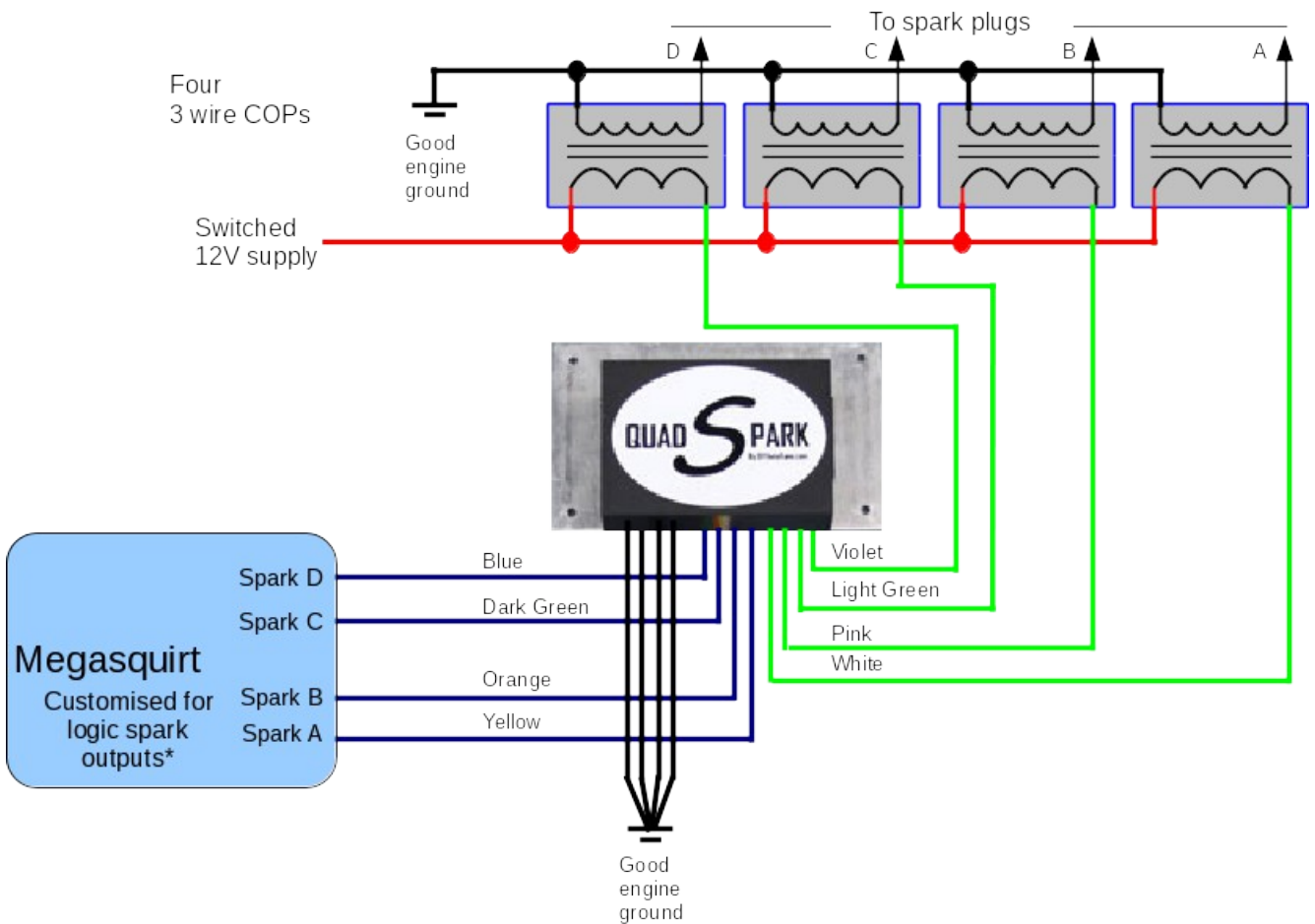

The diagram shows connection to COPs, but the module can also be used to drive high current coilpacks (Ford, Chrysler etc.)

5.3.4 High current coils

This type of coil requires an amplifier as per section 5.3.2



Shown are conventional single coil, GM wasted spark coil, Ford wasted spark coil-pack, Renault 2-wire COP. All of these coils are high current coils and require an ignition amplifier module (ignitor) to connect to the Megasquirt.

High current 2 wire

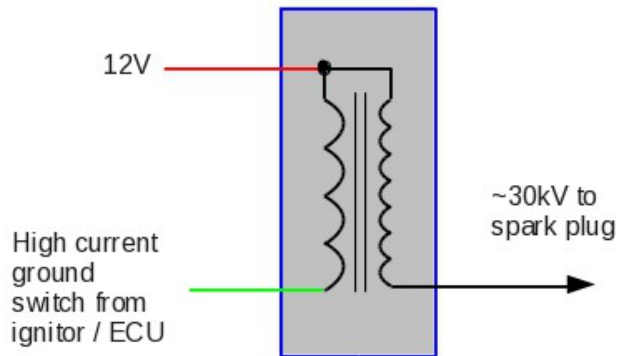

Conventional coils and "dumb" 2-wire COPs.

The connections are :

- switched/fused 12V supply
- output from ignitor.
The resistance measured between the inputs will be a few ohms only.

Requires an ignitor or customization for high current outputs 5.3.1.2

High current 2 wire wasted spark

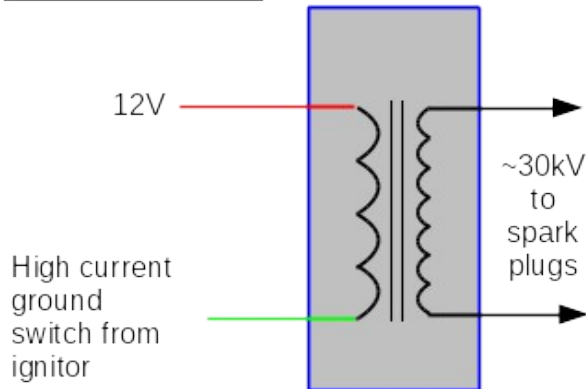

2 wire wasted spark coils - like the GM coil.

The connections are :

- switched/fused 12V supply
- output from ignitor.
The resistance measured between the inputs will be a few ohms only.

Requires an ignitor or customization for high current outputs 5.3.1.2

4-tower high current wasted spark coilpack

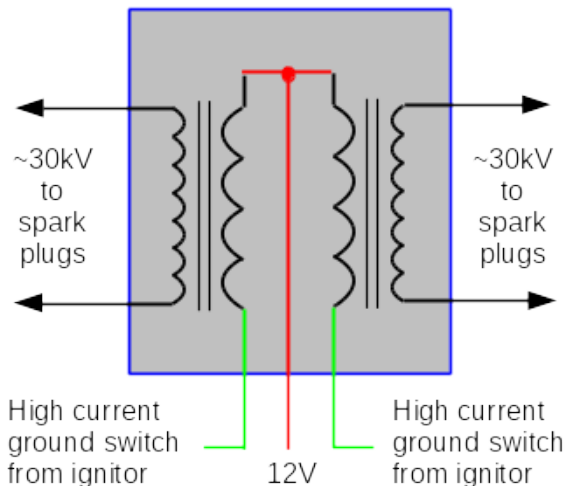

4-tower wasted spark coil-pack such as Ford (EDIS style) Neon, VW and others.

The connections are :

- switched/fused 12V supply
- output from ignitor (left and right)
The resistance measured between 12V and the primary wires will be a few ohms only.

Requires an ignitor or customization for high current outputs 5.3.1.2

5.3.5 CDI modules (e.g. MSD, Crane etc.)

Typical CDI units provide a "white wire" trigger input that can be connected to the Megasquirt for ignition control. Follow the manufacturers installation instructions for the other wiring. Ensure that no other trigger inputs are connected (e.g. green, violet.)

The following Ignition settings are required:

Set the Spark Output to "Going High"

Number of coils to "Single Coil"

Dwell to "Standard Dwell"

Spark A Output pin as "D14"

MSD is a well known brand and we will cover their wiring scheme here. Other manufacturers use similar wiring colors, but check the supplied diagrams.

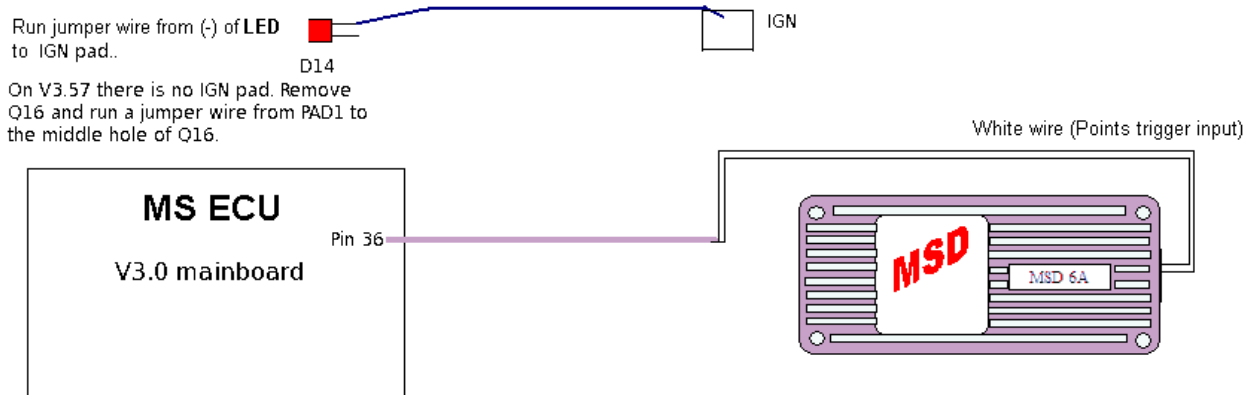

- tach signal is a yellow wire - do not connect this to Megasquirt.
- spark control signal is a white wire - connect this to the Megasquirt.
- ground is a heavy black wire
- permanent 12V power is a heavy red wire
- switched 12 volts is a thin red wire
- the coil positive (+) wire is orange
- the coil negative (-) wire is thin black
- the unused VR signal wires are green and violet.

With the MSD ignition box, we use the white 'points' input wire. Do not connect anything to the green and violet wires. The MSD box is only being used to fire the coil. The Megasquirt must receive its tach input from a crank or distributor pick-up.

5.3.6 Mazda Rotary ignition wiring

Early Mazda rotary engines used a distributor and conventional coils, these are not covered here.

Later engines used EFI and distributorless ignition with a number of specific multiple coil setups. In the tuning software, ensure that the engine stroke is set to "Rotary."

There are three main modes of the Megasquirt-2 rotary ignition support

- FC mode - uses a wasted spark coilpack for leading plugs and individual trailing coils. External ignitors are used. One for the leading coil and a combination ignitor for the trailing coils.
- FD mode - uses a wasted spark coilpack for leading plugs and individual trailing coils. External ignitors are used. One for the leading coil and one each for the trailing coils.
- RX8 mode - uses one logic coil per plug (four in total)

Mode ->	FC	FD	RX8
Number of coils	Wasted Spark	Wasted Spark	Coil on Plug
Output mode	FC	FD	FD
Spark A	Leading (IGt-L)	Leading	Front Leading
Spark B	Trailing Select (IGs-T)	Front Trailing	Front Trailing
Spark C	Trailing Trigger (IGt-T)	Rear Trailing	Rear Trailing
Spark D	(not used)	(not used)	Rear Leading

Set the Spark Output to Going High. Build circuit in 5.3.1.3

The leading coil feeds the upper spark plugs, and trailing the lower plugs. The front (crank pulley end) rotor is considered rotor 1.

Be aware that the output naming in "Output Test Mode Inj/Spk" is slightly different - coil A,B are the leading coils, coil C,D are the trailing coils. Note that this only applies to test mode, physical coil wiring must follow the above table.

Be sure to use the output test mode to confirm coil wiring before attempting a first start.

RX8 logic coils

Pin A = logic signal in

Pin B = power ground

Pin C = 12V supply

5.3.7 Toyota DLI ignition wiring

Some Toyotas use a system named "DLI" that connects between the ECU and the wasted spark coils. This uses a multiplexed signaling system. In the software settings ensure that "Toyota DLI" is selected.

Set the Spark Output to Going High. Build circuit in 5.3.1.3

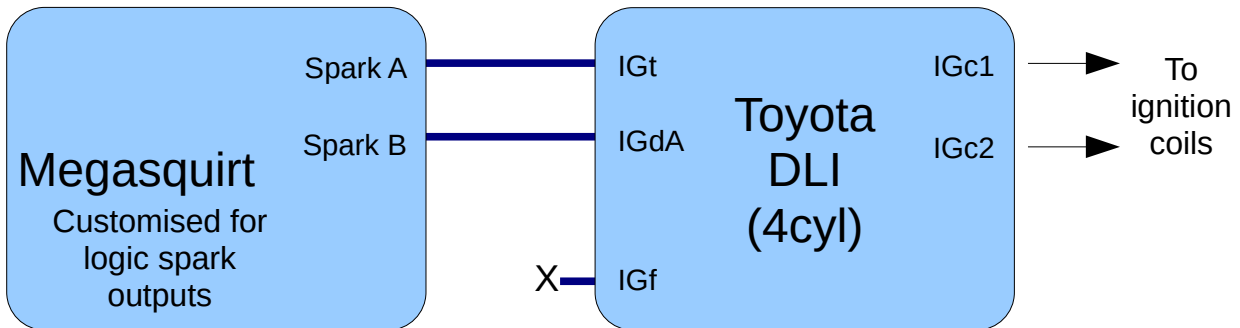

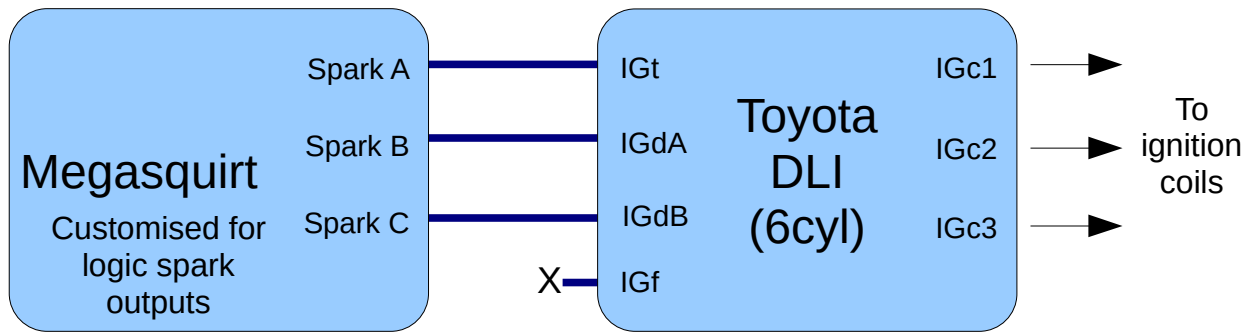

6 Ignition system - specific operating modes

The Megasquirt range supports many different tach input and output schemes including many OEM specific configurations.

For installations on engines without a supported tach input, a 36-1 trigger wheel on the crankshaft is the suggested setup.

Here are all of the 'spark modes' supported by the Megasquirt-2 product range and whether they support wasted spark (W/S) and COP/seq (coil-on-plug or sequential fuel) or not on a 4-stroke engine. 2-stroke engines only need a missing tooth wheel on the crankshaft for sequential fuel and spark.

Note that even if your trigger input could support COP/sequential, your ECU may not have enough outputs.

Spark Mode	Cam input needed ?	W/S ?	COP /seq ?	Applications
Fuel only	N	N	N	Various for fuel only (no spark control)
EDIS	N	Y	N	Early to mid 1990s Fords 4,6,8cyl
Basic trigger (distributor)	N	N	N	Widespread - HEI7, GMDIS, TFI, distributor
Trigger Return	N	N	N	Typically 1980s VW hall distributors
Toothed wheel "Missing tooth wheel" on crank "Missing tooth wheel" on cam "Missing tooth wheel" on crank + single tooth on cam "Dual wheel" non missing on crank + single tooth on cam (36-1, 60-2, 4-1, 24/1, 24/2, 6-1 etc.)	Varies	Varies	Varies	Ford, Bosch ECUs, very widespread. e.g. Ford, BMW, Vauxhall/Opel, many Japanese vehicles using Nippondenso CAS, GM LS2 This is the most common selection covering thousands of installs. See detail pages for all variations
Neon/420A	N	Y	If cam used	420A Neons
36-2+2	N	Y	If cam used	"Next Generation" Crank Chryslers
36-2-2-2	N	Y	If cam used	Some Subaru and Mazda RX8
Miata 99-00	Y	Y	Y	1999-2005 Miata with 4 tooth crank trigger and 1,2 cam trigger. VVT not supported on Megasquirt-2
Subaru 6/7	Y	Y	Y	Subarus flat fours
6G72	Y	Y	Y	
IAW Weber*	Y	Y	Y	Fiat / Cosworth engines with 4 tooth crank trigger and uneven distributor trigger.
CAS 4/1*	Y	Y	Y	
4G63	Y	Y	Y	Mitsubishi, Mazda Miata (MX5)
Twin trigger*	(Y)	Y	N	Bike engine with one reluctor and two trigger coils. Typically 4 cylinder wasted-spark.

Spark Mode	Cam input needed ?	W/S ?	COP /seq ?	Applications
Chrysler 2.2/2.5*	Y	Y	Y	Distributor pickup. YMMV
Renix 44-2-2	N	N	N	Renault 4cyl, also V6 with 66-2-2-2
Suzuki Swift*	N	N	N	Distributor trigger wheel
Suzuki Vitara 2.0*	N	Y	N	Suzuki Vitara 2.0
Daihatsu 3cyl*	N	N	N	3+1 cam trigger
Daihatsu 4cyl*	N	N	N	4+1 cam trigger
VTR1000*	N	Y	N	12-3 on crank
Rover#1*	N	?	N	Rover K Series 36-1-1
Rover#2*	N	?	N	Rover K Series 36-1-1-1-1
Rover#3*	N	?	N	Rover K Series 36-2-2
GM7X*	N	Y	N	Direct from sensor bypassing GMDIS modules.
QR25DE*	Y	Y	Y	Nissan
Honda RC51*	Y	Y	Y	Also other versiants
LS1	N	Y	N	GM LS1, LM7 etc. with 24X crank
YZF1000*	?	?	?	
HD 32-2*	N	N	Y	Harley 45deg V-twin. Can use MAP sensor for phase detection or use a cam sensor.
Miata 36-2*	N	Y	N	Flyin' Miata custom 36-2 wheel fitted to 99-05 engine.

* indicates a configuration that has received less usage in the field and may be less well proven. Proceed with caution or discuss with your supplier before using.



Running excessive timing under load will almost always cause severe engine damage such as broken pistons.

It is essential that timing is confirmed with a timing-light on EVERY install.

NOTE! The tach input polarities provided in section 6 are for reference only and subject to review.

6.1 Coil negative for fuel only

For fuel-only installs it is possible to obtain a tach in trigger from the negative terminal of a single coil. Note that this won't work well on a wasted spark setup and must never be connected to a CDI type coil with a high primary voltage.

Coil negative input CANNOT be used for installs using the Megasquirt to control ignition.

Coil negative (not CDI)



Typical Settings

Spark mode = "Fuel only"

Set mainboard for Optoisolator input as per section 5.2.1

6.2 Distributor pickup

The distributor is the traditional method of timing spark and distributing the high-tension spark voltage to individual spark plugs. Typically this used a set of breaker points, a condenser and a single ignition coil. Most distributors feature mechanical and vacuum advance systems to match spark timing somewhere close to optimal for different operating conditions. Later systems were "breakerless" and replaced the high-maintenance points with VR, hall or optical sensors. When combined with OEM fuel injection systems, the distributor may be "locked" in that there is no advance mechanism - the timing is controlled by the computer. Some OEM systems retain a distributor only for the high-tension spark distribution and use a trigger-wheel arrangement for tach input.

The first step in an install is to identify what kind of system is already fitted to your engine. Usually this is relatively straight forward to establish.

Note that Ford TFI, GMHEI7, GMHEI8 are special cases using a locked distributor and are covered in their own subsections.

6.2.1 Traditional vac/mech distributor

For distributor triggering you need one pulse per spark event. e.g. a normal distributor on a typical 4 stroke, 4 cylinder engine will have four lobes/teeth/vanes/slots in the distributor.

This applies to points, optical, VR, hall.



See section 5.2 for wiring details on the tach input.

VR-type mechanical/vacuum advance distributor

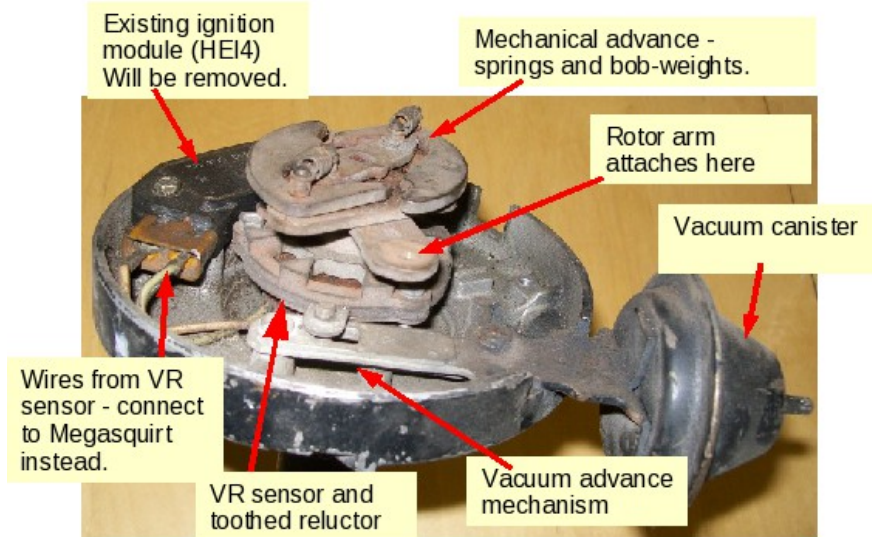

Shown above is a "large cap" General Motors HEI4 distributor, typical on mid 1970s V8s.

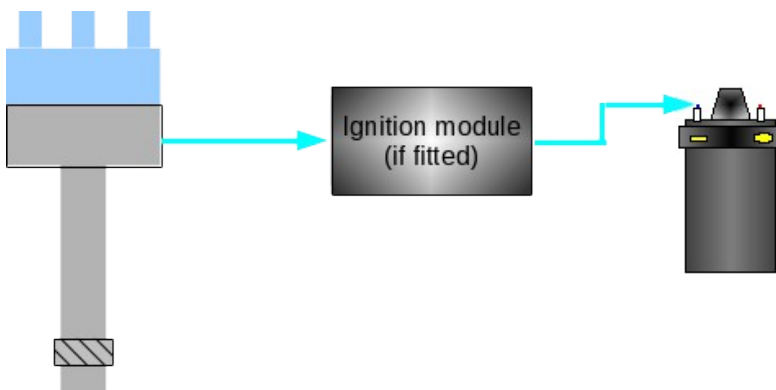

Typical original arrangement

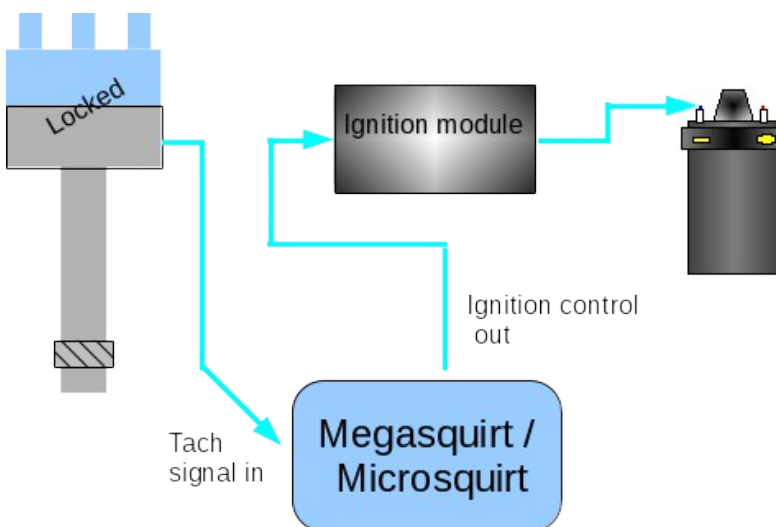

Typical arrangement with ECU ignition timing control and locked distributor

6.2.1.1 Input phasing

A typical distributor includes advance mechanisms which were originally used to control the timing. These are not used when using computer control and must be locked out to give a "locked" distributor.



Correctly modifying an old distributor to give a reliable tach input may well be more difficult than adding a crank trigger wheel and will never be as accurate. You are advised to consider installing a crank trigger wheel (e.g. 36-1) and sensor instead.

Early distributors such as points, HEI4, Duraspark etc, all have advance mechanisms built in. The HEI4 distributor shown above illustrates these mechanisms and is typical of pre-computer distributors. Similar distributors can be converted to computer control-

Remove ignition module (if present)

Connect pickup sensor (VR, hall, opto, points) to ECU.

Remove and weld up mechanical advance mechanism.

Remove vacuum canister.

Use remnants of vacuum advance mechanism to achieve correct input:output phasing.

You may be able to set the rotor output phasing FIRST and then rotate the baseplate to achieve the correct input phasing.

Later engines may feature a distributor in conjunction with computer controlled timing - usually these distributor are "locked" from the factory and should already have good input and output phasing. (e.g. Ford TFI, GM HEI7/8, Bosch hall effect.) Align as per the factory manuals and determine how it is phased before you modify anything!

The crank angle at which the tach input triggers is of importance and needs to be configured in the Megasquirt. For best spark control there are some optimal and some disallowed crank angles.

A typical engine will have an operating advance range of say 10-50 BTDC timing (depending on engine type.) The trigger must not happen during this range of angles.

It can be really helpful to install timing tape on your crank pulley or temporarily mark on a range of angles.

For best accuracy at high revs or during transients, aim for the trigger to align at 60-90 BTDC. This also allows a full range of timing (including ATDC timing should you need it for boosted conditions.) This range of trigger angle is preferred for new installs.

For slightly better starting, but not quite such good running accuracy, aim for a trigger ~10BTDC or your desired cranking advance. This is the typical trigger angle for TFI and HEI7/8. You cannot retard timing later than the trigger angle. e.g. 9BTDC and lower are not possible with a 10 BTDC trigger angle.

The VR sensor input presents a simple pulse as the reluctor passes the sensor, this gives a timing position easily identified by eye. Use "Basic Trigger"

Rotate the engine to 60 BTDC (or 10 BTDC if chosen) and then align the distributor so the reluctor aligns with the center of the sensor.

VR type distributor pickup

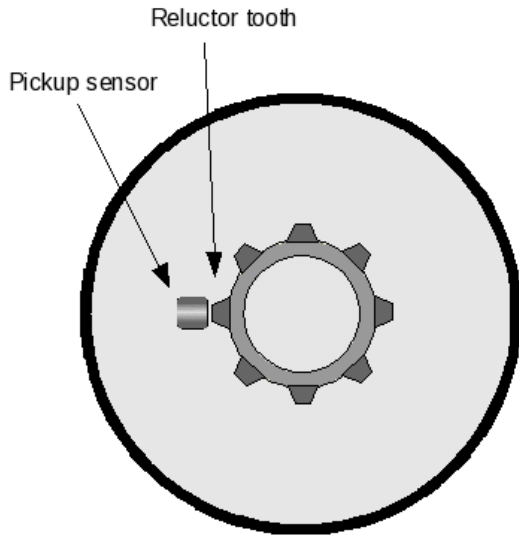

Reluctor aligns with sensor
Engine @ XX BTDC
This is the trigger angle/offset

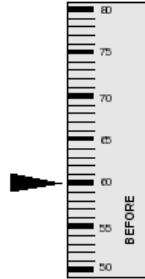

Timing marks on damper

Be aware of the allowable values for "trigger angle". Do not use angles in the disallowed range or you will have unreliable or unexpected operation.

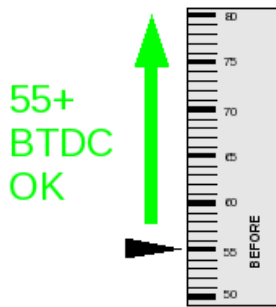

Timing marks on damper

Allowed high angles

Timing allowed in normal range (up to 5 degrees less than trigger angle.) Retarded ATDC timing possible.



Timing marks on damper

Disallowed angles.

Do not use a trigger angle between 16 and 54 degrees.

Timing will not work correctly.

Distributor must be moved or re-phased.

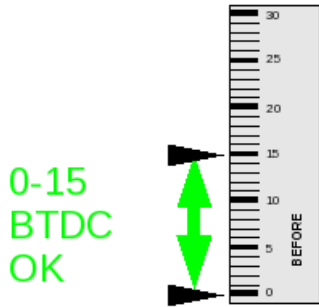

Timing marks on damper

Allowed low angles

Timing allowed in normal range (greater than trigger angle.) Retarded ATDC timing not possible.

Once the tach input is setup it is important to confirm the output phasing is correct.

6.2.2 Rotor / Output phasing - all distributor installs



Rotor phasing is CRITICAL. Without it you will get cross firing and the engine will run extremely badly.

Rotate your engine to ~25 BTDC.

The rotor arm MUST point towards a tower on the distributor.

Distributor rotor phasing

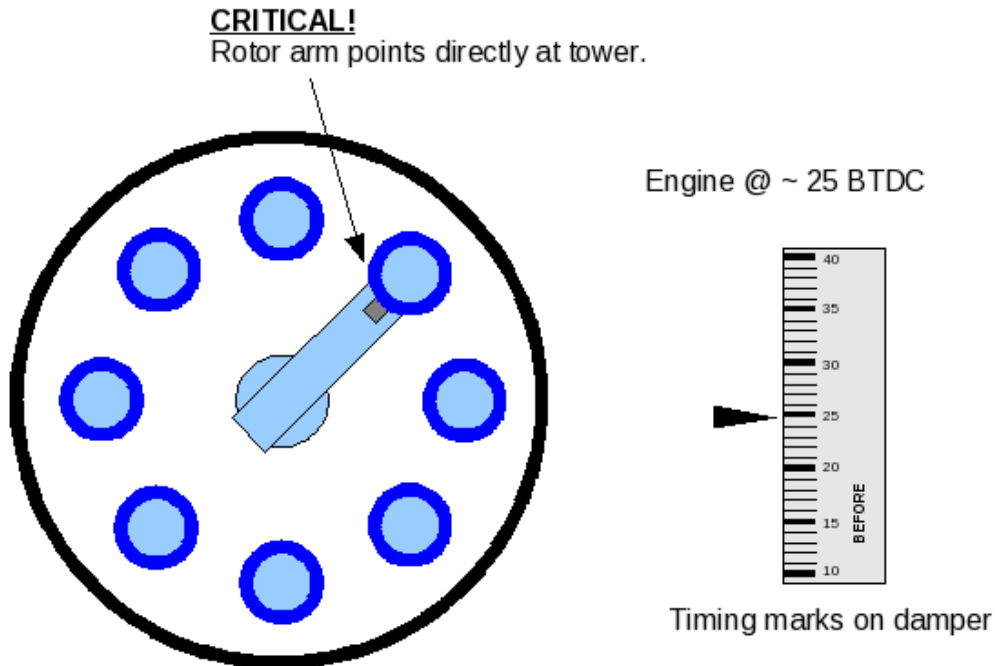

When using the distributor for the tach input as well, beware of just rotating the distributor - that would change the input phasing that you already set - you may need to make a physical modification to rotate the rotor arm. (e.g. weld up the locating slot and cut a new one.) If you moved the distributor, go back and re-set the input phasing.

This potential conflict between input and output phasing is why a crank trigger is strongly recommended.

If you are crank triggering and the distributor is only used for the spark distribution then you can simply rotate the dizzy to achieve the required rotor phasing. In this case it is not necessary to 'lock' the distributor, you can

unhook the vacuum canister and leave the mechanical advance operational.

6.2.3 Distributor with hall/optical 'trigger return'

The purpose of the "Trigger Return" mode is to have accurate cranking timing as well as accurate running timing. It achieves this by using the signal from both edges of a vane/slot. One edge is used for the timing calculations during running and will typically pass the sensor at 55BTDC or more. The other edge is used for cranking timing and must pass the sensor at the desired cranking advance angle e.g. 10BTDC

This scheme was commonly used by VW during the 1980s with a locked hall-effect distributor.

 'Trigger return' may only be used if the slots/shutters/vanes in the distributor are evenly spaced and equal sized.

Do not try to use 'trigger return' with many Nissan optical pickups or with signature-PIP TFI as these have uneven slots/vanes.

 See section 5.2 for wiring details on the tach input.

Configuring trigger return requires knowing the crank angle that each vane edge passes the sensor. You can check this visually or by wiring up the system and using a multimeter to measure the output from the sensor.

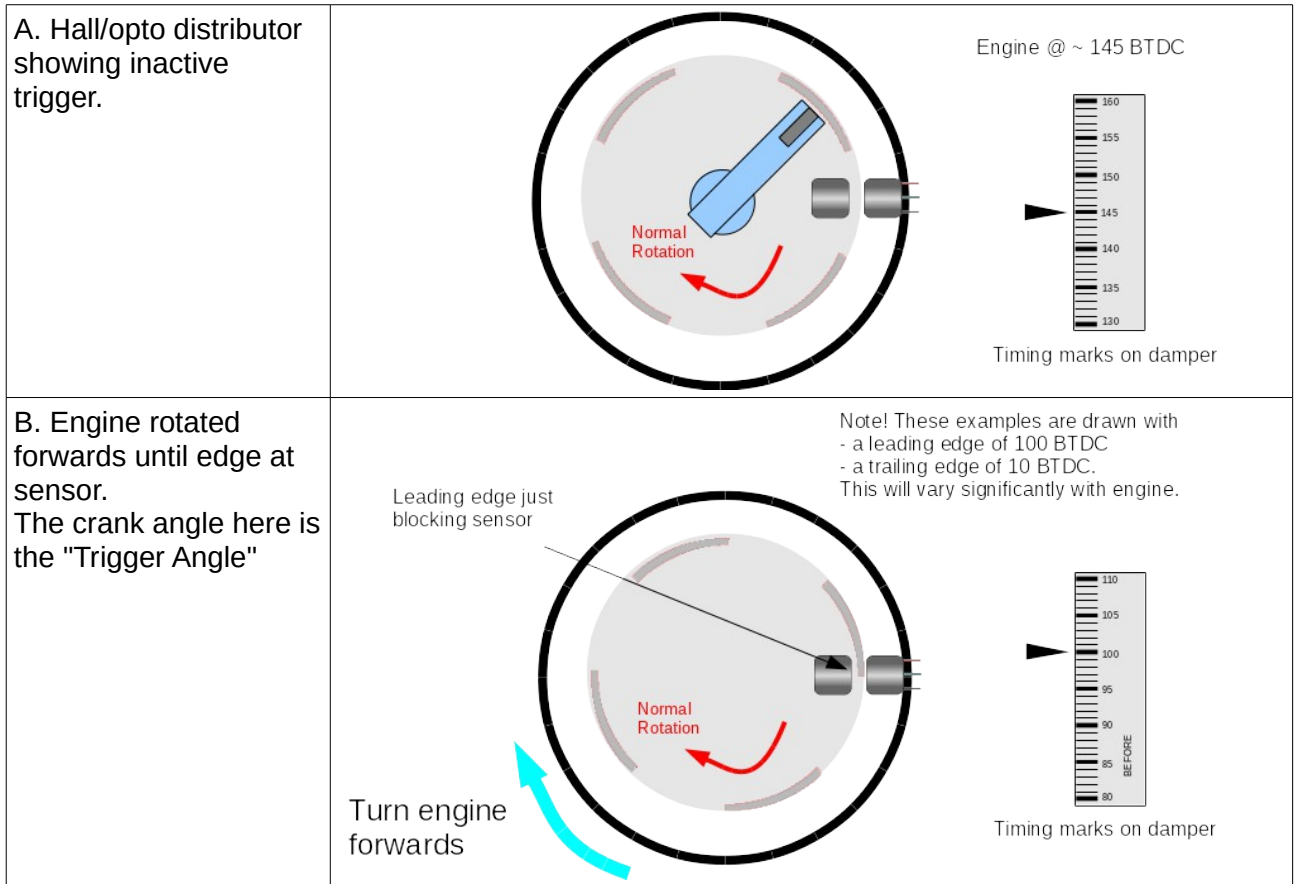

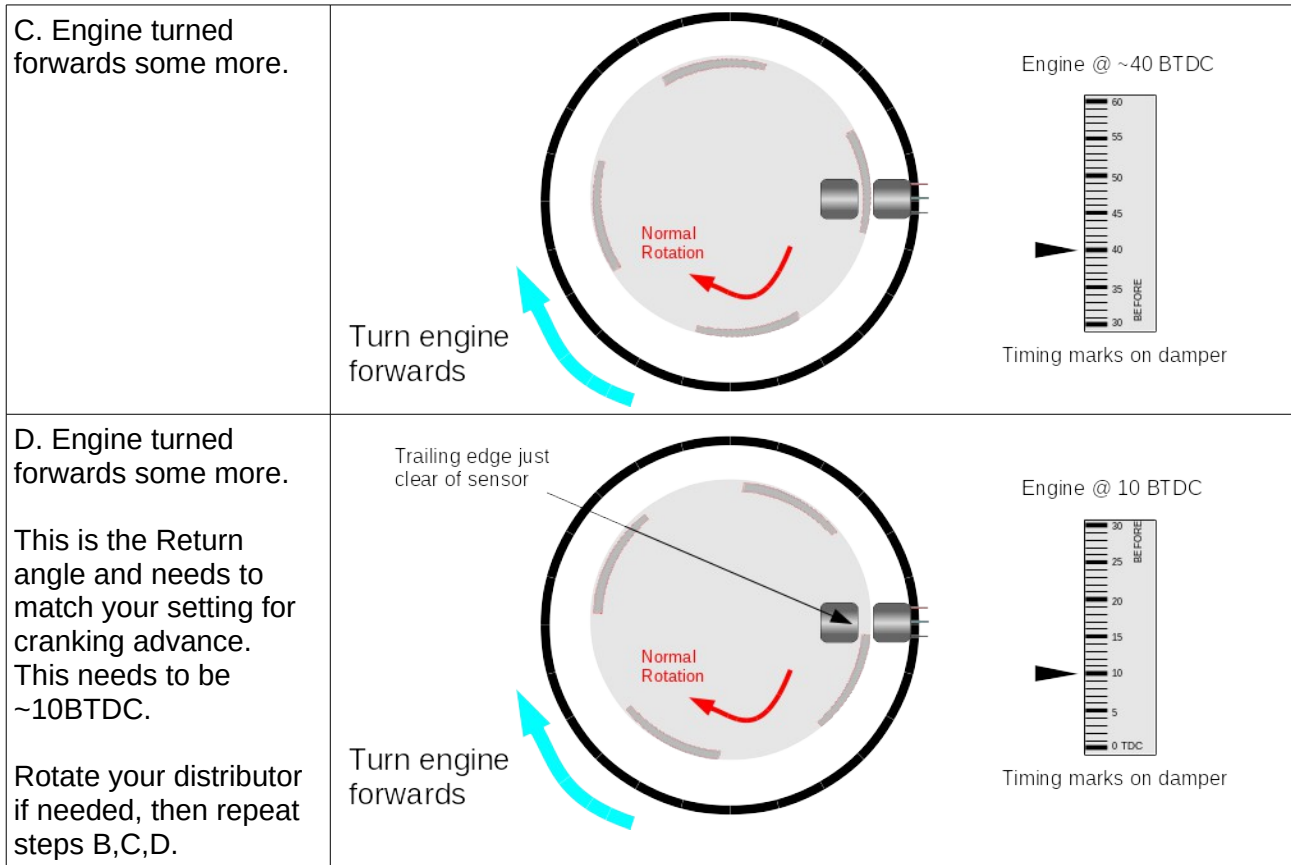

The output phasing on an OEM trigger-return type distributor installed in the normal position should not require adjustment.

6.2.4 Distributor with basic crank trigger

Installing a "flying magnet" crank trigger gives more accurate ignition control than using a distributor based pickup as it eliminates timing chain and cam-gear slop. It also eliminates the hassle of re-phasing the distributor.

For best timing accuracy, it is recommended that the flying magnet passes the pickup sensor when the engine is around 60BTDC.



See section 5.2 for wiring details on the tach input.

Typical Settings

Spark mode = "Basic Trigger"

Trigger angle/offset = 60 BTDC (adjust as required)

Ignition capture = Set according to whichever edge gives the most stable signal. (If timing advances with RPM, try flipping it.)

Spark output = depends

Spark A output pin = depends

Dwell type = depends

Dwell duty = depends

6.2.5 Distributor with crank trigger wheel



This is the preferred method to use with a distributor.

Using a trigger wheel (e.g. 36-1) on the crank is the most best way to obtain accurate ignition control. The ECU uses every tooth on the wheel to determine engine position. It eliminates timing chain and cam-gear slop. It also eliminates the hassle of re-phasing the distributor.

The distributor and single coil can be retained, but you have the option of a future upgrade path to wasted-spark or perhaps coil-on-plug ignition.

The setup and configuration of the crank trigger wheel is covered in the Toothed wheel section 6.9.

6.3 Ford TFI

Ford's TFI module was used throughout the 1980s and into the 1990s on many millions of vehicles in two main mounting positions - 'distributor mount' and 'remote mount'. There are also two electrical versions: "Push Start" and "Computer Controlled Dwell". Checking the wiring on pin4 is likely best. The wiring of the modules is largely the same, just the distributor mount connects directly to a 3 wire hall sensor in the distributor. In most installations you do not need to concern yourself with that as only the 'PIP' and 'SPOUT' connections are of interest. The other connections should be left stock.

Push-Start (PS) vs. Computer Controlled Dwell (CCD)

The module described mainly here is the 'PS' type that uses a 12V start signal, it is claimed to be gray in color. 50% dwell duty should be used.

The 'CCD' type is claimed to be black in color. and pin 4 runs as a diagnostic signal to the original ECU. These modules need standard dwell control e.g. 3ms instead of a fixed duty. Other wiring should be the same.

Base Timing and phasing

"Base Timing" on the distributor (with computer control 'SPOUT' disconnected) is around 10BTDC. This is the number you should use as your initial Trigger Offset. As these distributors were designed for ECU control, the rotor arm phasing should already be correct.

Signature PIP

Note that there is a TFI variant with "Signature PIP" that in the original install allows for cylinder identification and sequential fuel. This signature is not used in Megasquirt-2.

These distributors should be configured as "Basic Trigger".

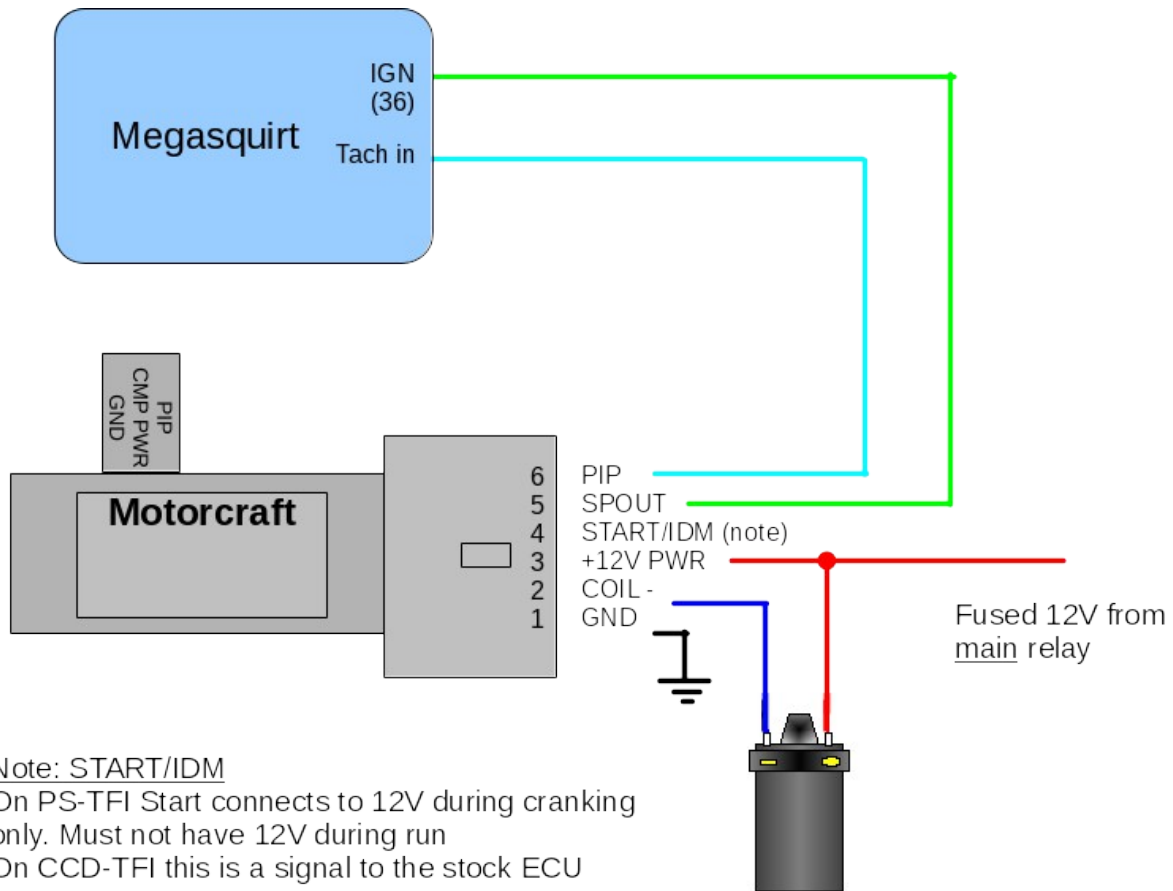

Set the mainboard as per section 5.2.4

Make the following modifications:

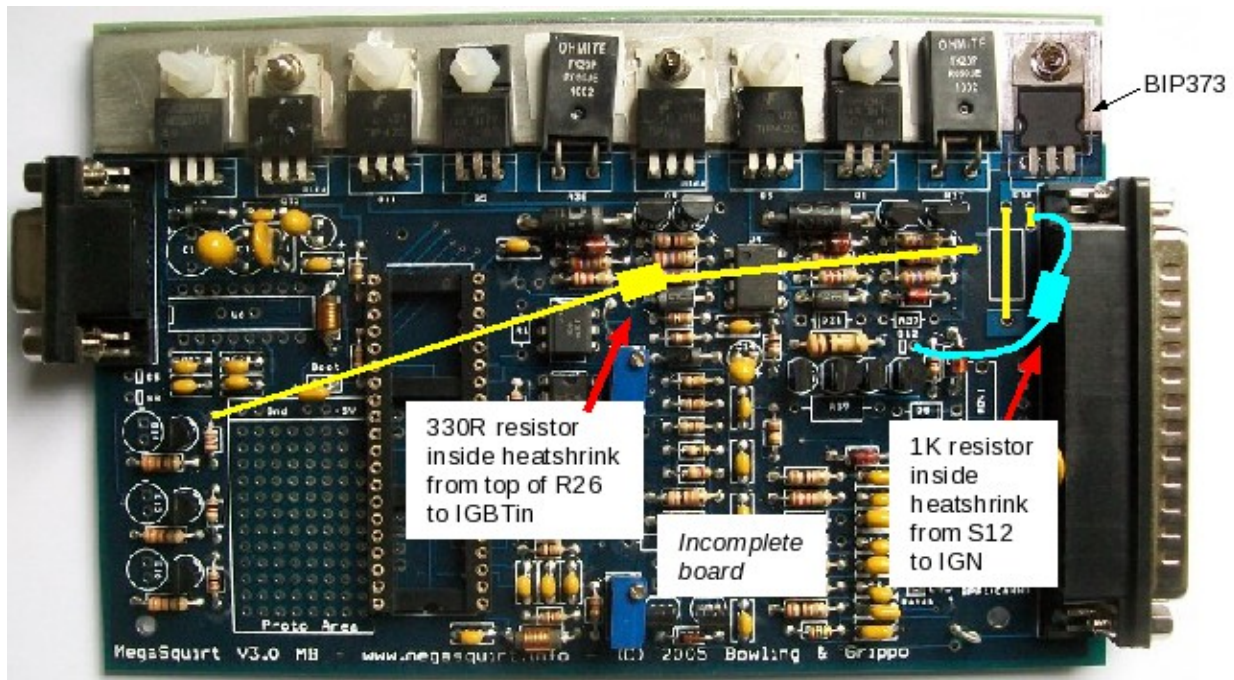

Typical Settings

Spark mode = "Basic Trigger"

Trigger angle/offset = 10 BTDC as a starting point, fine tune with a timing light.

Ignition capture = "Falling edge"

Spark output = "Going High"

Spark A output pin = "D14"

Dwell type = "Fixed duty"

Dwell duty = "50%"

6.4 GM HEI7

The original "High Energy Ignition" (HEI) distributors used the 4 pin module from the early 1970s is fine in the breakerless distributor as designed, but is not suitable for computer timing control. The later 7 and 8 pin modules and corresponding distributors are designed for computer control and should be an easy swap onto earlier engines - not only are those modules intended for computer control, but their distributors are already locked-out so no modifications are required. HEI7/8 uses three control wires to/from the Megasquirt.

The 'Ref' signal from the module to the Megasquirt gives rpm and engine position information.

The 'Est' signal from Megasquirt to the module controls the advance when running.

The 'Bypass' signal from Megasquirt to the module allows the module to beneficially control its own advance during cranking. Once the engine has been running for more than 5 seconds, the Megasquirt takes control of timing.

P = Positive from VR sensor

N = Negative from VR sensor

E = Electronic spark timing (EST) from Megasquirt IGN

R = Reference (REF) to Megasquirt Tach in

B = Bypass from Megasquirt bypass output (SPR3 shown)

Set the mainboard as per section 5.2.4

Make the following modifications:

Add 1k 1/8W resistor from (-) of D14 to the right hand side of the resistor below.

Add 1k 1/8W resistor from (-) of D16 to the right hand side of the resistor below.

Jumper from (-) of D14 to IGN

Jumper from (-) of D16 to SPR3 (or your chosen pin)

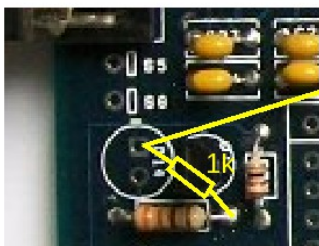

Add two 1k 1/8W resistors as shown. One on D14, one on D16



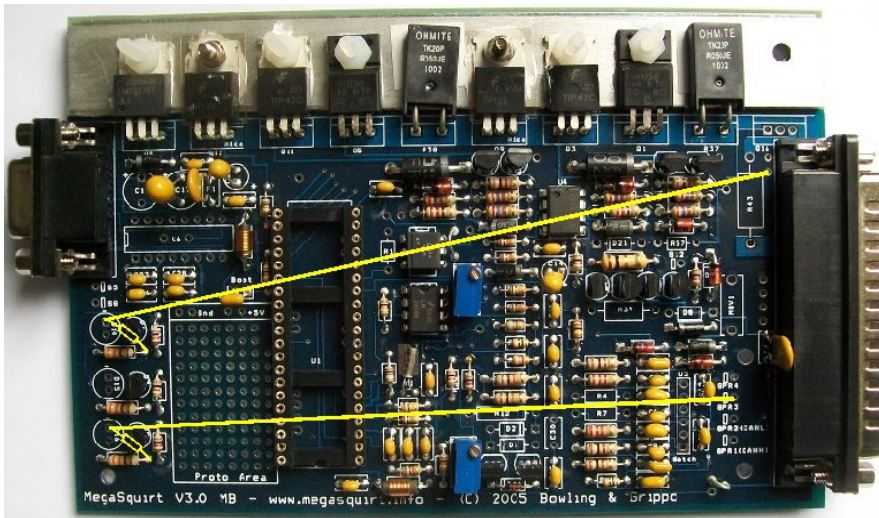

Jumper

D14- to IGN

D16- to SPR3

(ensure nothing else is connected to 'IGN' or 'SPR3')

HEI7 General layout

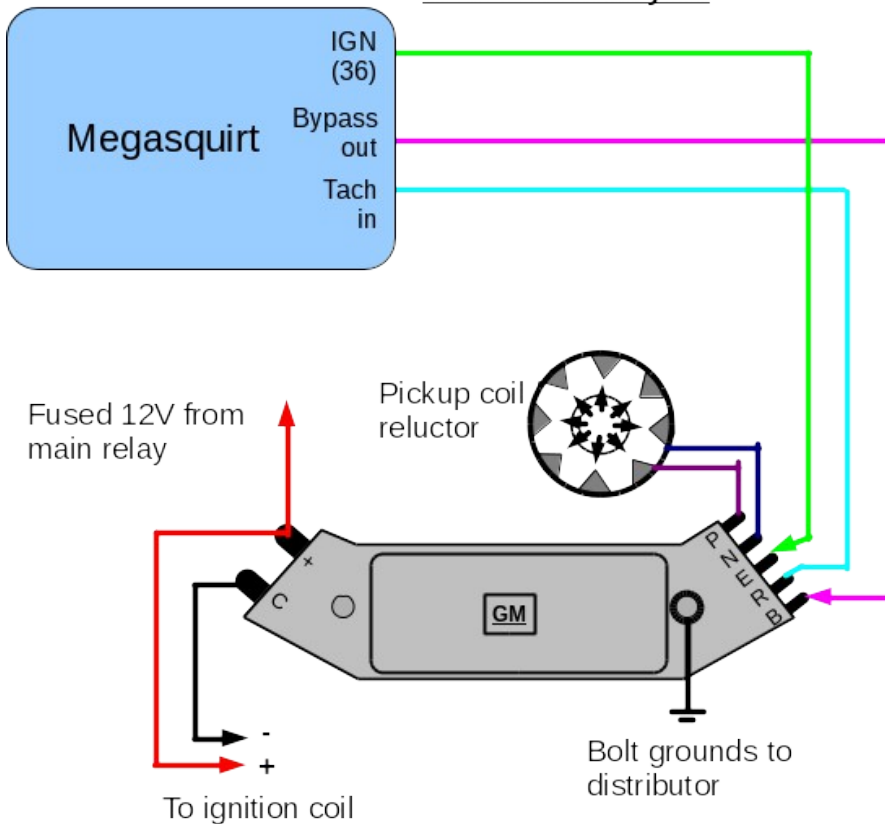

Typical Settings

- Spark mode = "Basic Trigger"
- Ignition capture = "Rising Edge"
- Spark output = "Going Low"
- Spark A output pin = "D14"
- Dwell type = "Standard Dwell"
- Nominal Dwell = "3.0"

GM/HEI options = "GM bypass"

6.5 GM HEI8

This works the same as HEI7, but the module is packaged differently.

The same internal modifications are required as for HEI7 in section 6.4

P = Positive from VR sensor

N = Negative from VR sensor

G = Ground to Megasquirt Sensor ground

B = Bypass from Megasquirt bypass output (SPR3 shown)

R = Reference (REF) to Megasquirt Tach in

E = Electronic spark timing (EST) from Megasquirt IGN

HEI8 General layout

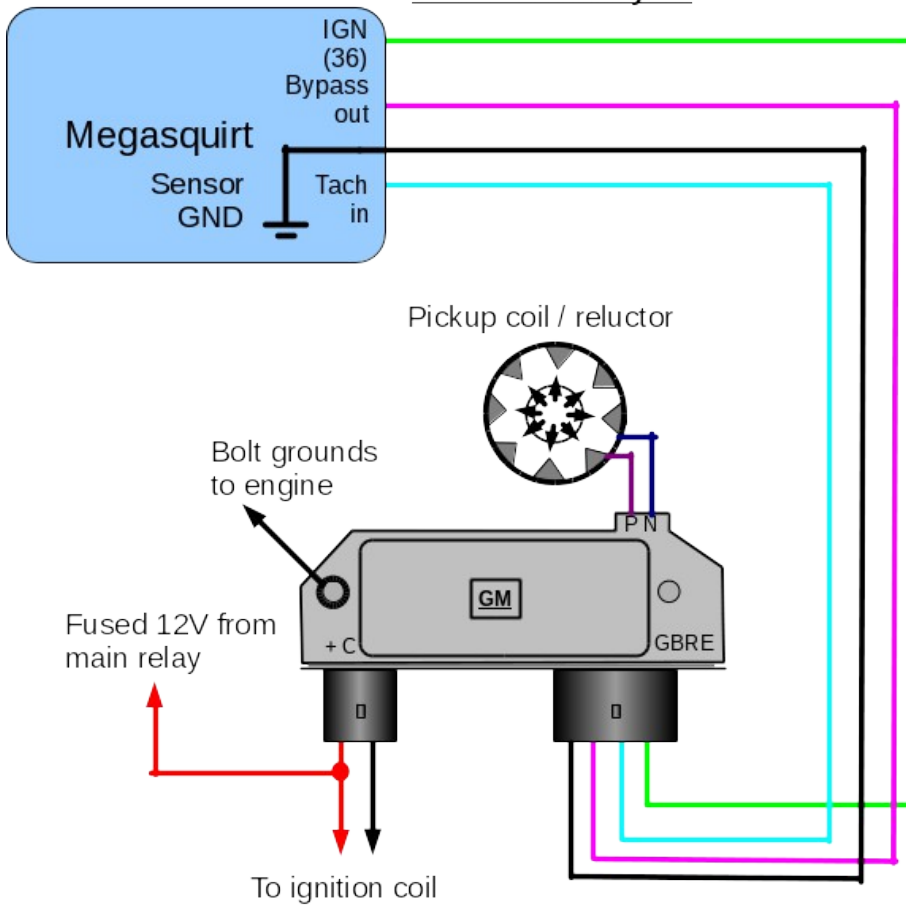

Typical Settings

Spark mode = "Basic Trigger"

Ignition capture = "Rising Edge"

Spark output = "Going Low"

Spark A output pin = "D14"

Dwell type = "Standard Dwell"

Nominal Dwell = "3.0"

GM/HEI options = "GM bypass"

6.6 Dual Sync Distributor

A dual-sync distributor is an aftermarket locked distributor that provides a clean trigger signal for an ECU. The signal can be used for sequential fuel in some situations.

As Megasquirt has only two fuel channels, it is simplest to ignore the "reference" signal from the distributor and configure as a regular distributor using "Basic Trigger."

Setting the rotor arm phasing is important as shown in 6.2.1.2.

Alternative: It is possible to use both signals from the dual-sync distributor and control a distributorless ignition system (wasted spark or wasted-COP.) In this case use the "Dual wheel" option in the Trigger Wheel system. Setting the rotor arm phasing is important as shown in 6.2.1.2, then determine the tooth#1 angle from the Trigger Wheel page.

6.7 Ford EDIS



Ford's Electronic Distributorless Ignition System (EDIS) is an ignition system that does not require a cam position signal. It requires a variable retractor (VR) sensor and a 36-1 tooth crank wheel (36-1 means '36 teeth minus one', and refers to 36 evenly spaced teeth, one of which has been removed), it will not work with other pattern wheels or hall sensors.

EDIS is a particularly easy way to install programmable ignition control on an older engine with a distributor. The EDIS modules are very reliable and the system works well. The EDIS module itself handles all the decoding of the toothed wheel and sends one pulse per cylinder to the ECU.

It is strongly advised to use Ford VR sensors and Ford coilpacks with the EDIS modules. They were designed to work together and do.

Note! If your engine already has a different supported trigger wheel setup, consider utilizing that before retrofitting EDIS.

6.7.1 System components

The EDIS system is made up of:

- EDIS module,
- crank wheel,
- crank variable retractor (VR) sensor and
- one or more coil pack(s).

See appendix B for a junk-yard hunters guide to finding EDIS.

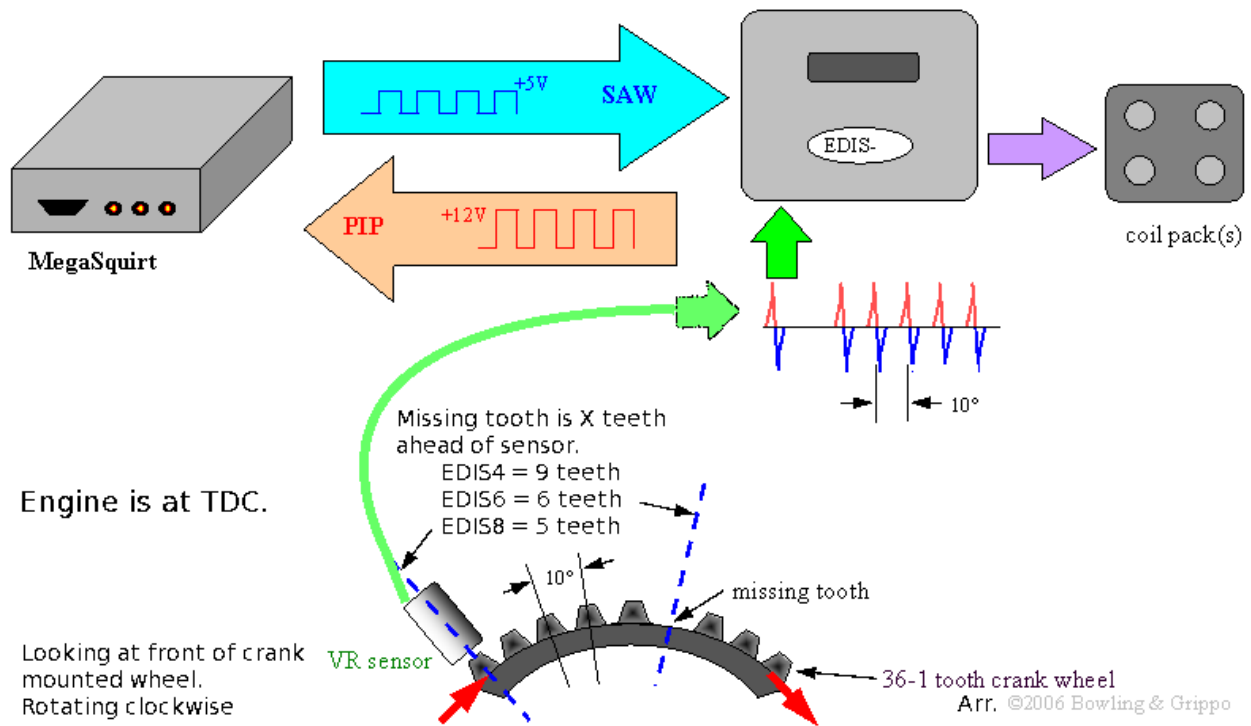

6.7.2 ECU wiring

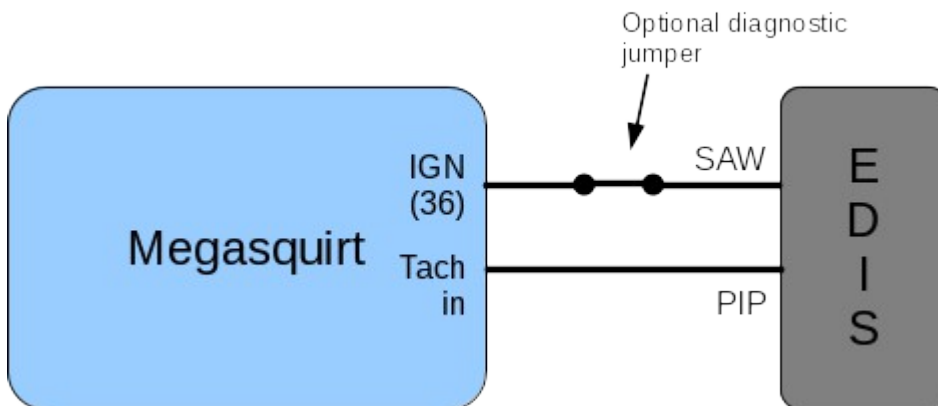

Set the mainboard as per section 5.2.4.

The following internal modifications are required:

- a) Ensure that Q16 is not fitted.
- b) Run a jumper wire from JS10 to IGN

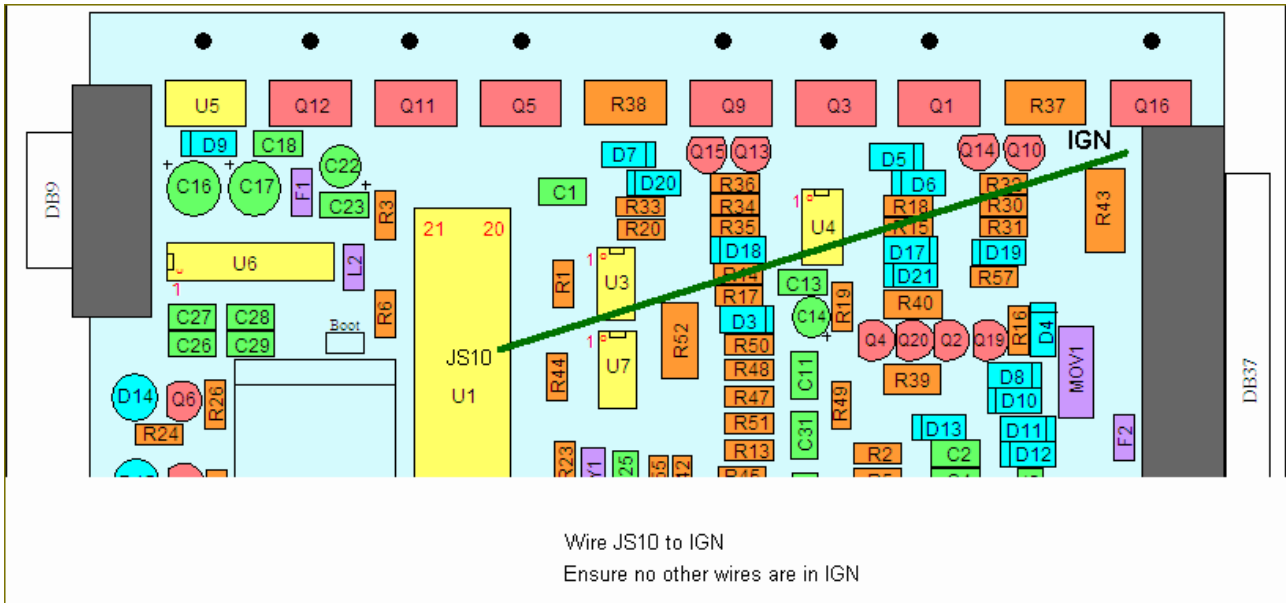

Typical Settings

Spark mode = "EDIS"

Ignition capture = "Rising Edge"

Spark output = "Going High"

Spark A output pin = "JS10"

6.7.3 Module wiring

The EDIS system comes in three varieties : EDIS4, EDIS6, EDIS8 which are suited to even-fire 4, 6, 8 cylinder engines. The specific wiring of the module varies slightly between the variants.

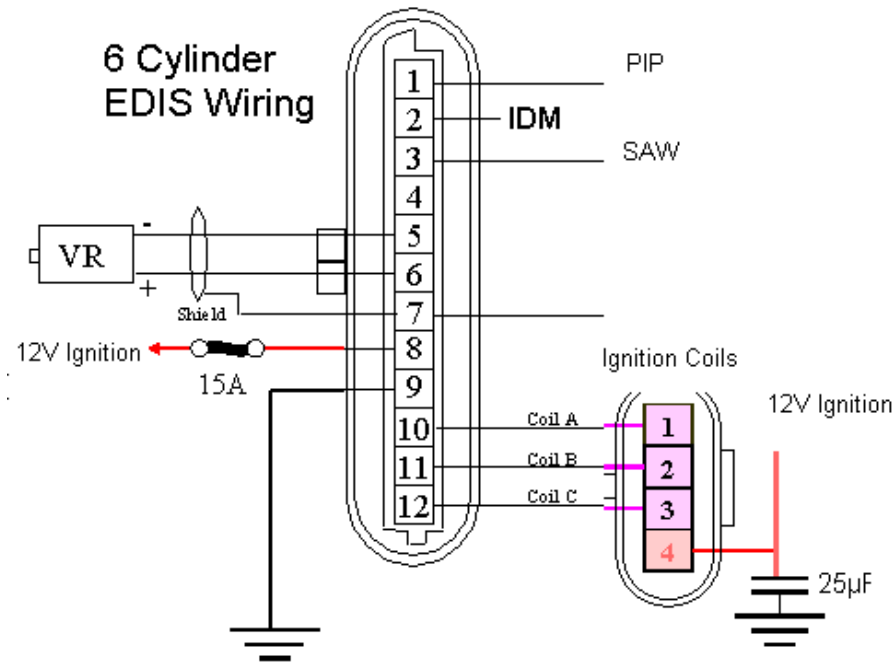
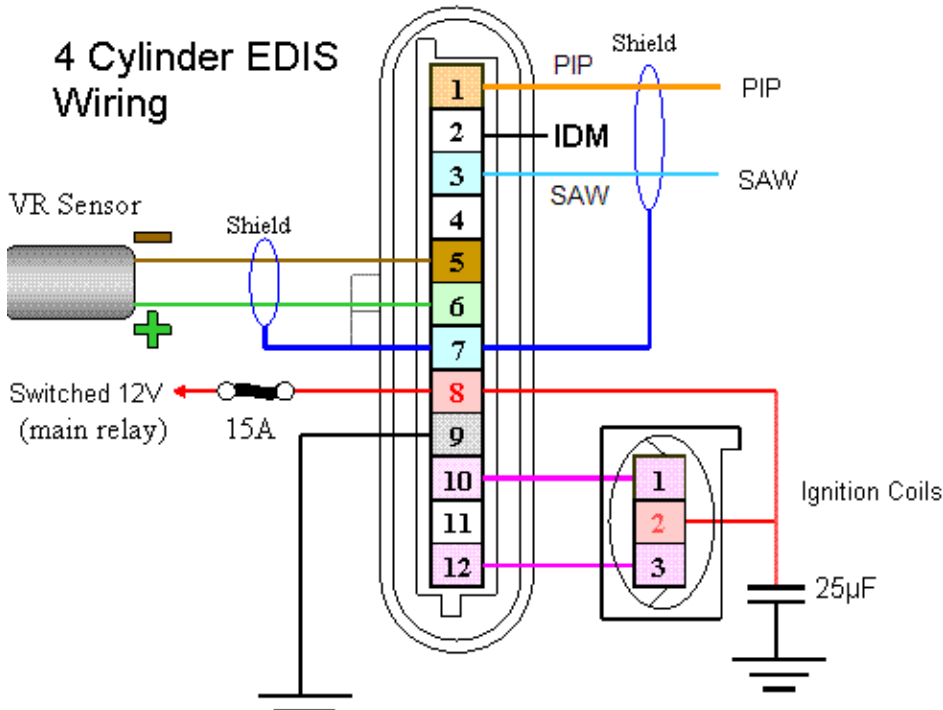

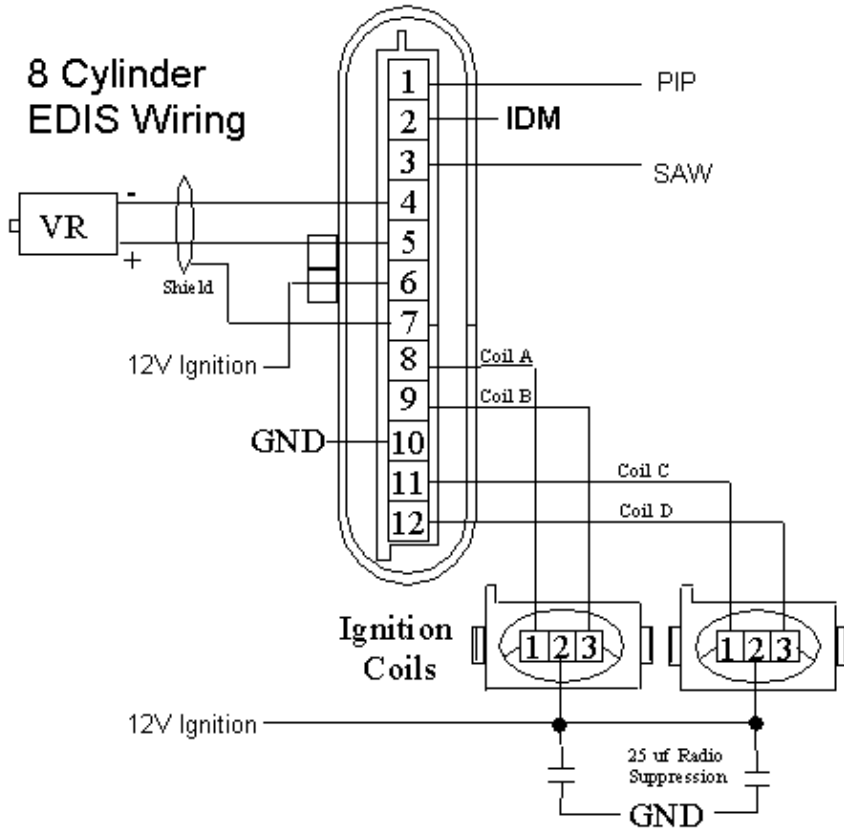

6.7.4 36-1 trigger wheel and VR sensor

The relationship of the VR sensor and the missing tooth is critical. The EDIS module expects and requires a specific phasing.

On engines originally equipped with EDIS this will already be set. Later Ford engines also maintain the same phasing even though the EDIS function is now built into the ECU.

Note that while the relationship of the VR sensor and the missing tooth is critical, the actual placement of the VR sensor on your engine is not. i.e. the VR sensor could be at 12 o'clock, 3 o'clock, 6 o'clock, 9 o'clock - it really does not matter - so long as the wheel is phased to match.

See the diagrams below EDIS4, EDIS6, EDIS8. The main diagrams show clockwise engine rotation as that is the most common, there is an anti-clockwise example afterwards.

For each module type there are two phasing diagrams shown.

Both methods achieve the same result.

- method a - engine is set to TDC and teeth counted
- method b - engine is set to angle X BTDC and missing tooth aligned with sensor

Use method 'a' if you can. Alternatively, some installers may find method b easier to understand.

6.7.4.1 EDIS4 - Clockwise rotation (normal) - method a

Set your engine at TDC, then put the missing tooth 9 teeth earlier (more clockwise) than the sensor. This will put the center of a tooth central to the sensor.

EDIS4 - 9 teeth offset

With engine at TDC, the VR sensor aligns with the 9th tooth

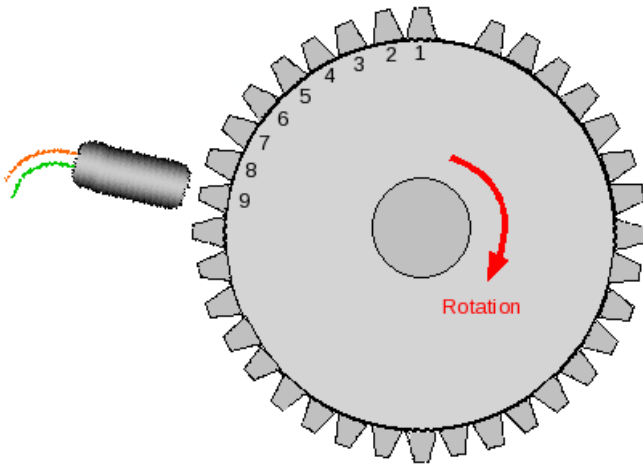

Timing marks on damper

Clockwise rotation

6.7.4.2 EDIS4 - Clockwise rotation (normal) - method b

Turn your engine to 90 BTDC. Mount the VR sensor wherever is convenient and mount trigger disc so that the center of the sensor aligns with the center of the missing tooth.

EDIS4

This shows another view of the **same** sensor to missing-tooth alignment. When the missing tooth is lined up with the sensor the engine is at 90 BTDC

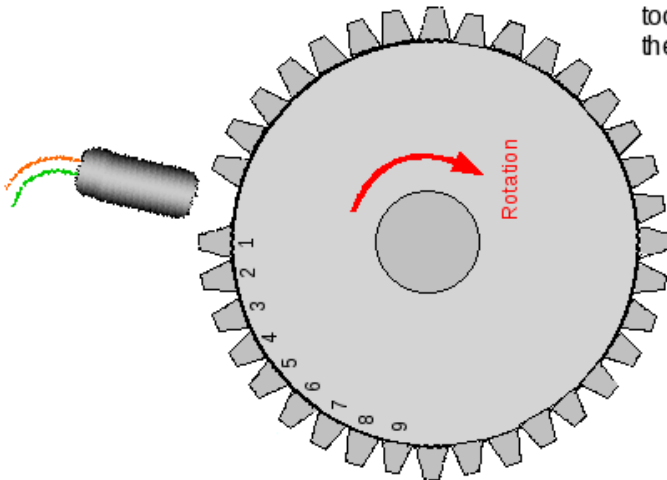

Timing marks on damper

Clockwise rotation

6.7.4.3 EDIS6 - Clockwise rotation (normal) - method a

Set your engine at TDC, then put the missing tooth 6 teeth earlier (more clockwise) than the sensor. This will put the center of a tooth central to the sensor.

EDIS6 - 6 teeth offset

With engine at TDC, the VR sensor aligns with the 6th tooth

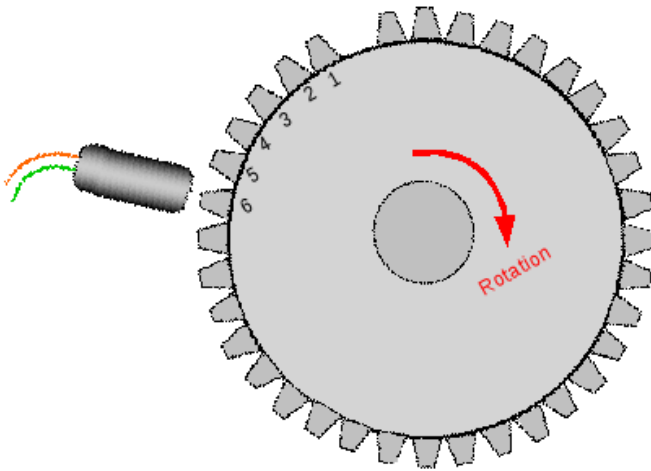

Timing marks on damper

Clockwise rotation

6.7.4.4 EDIS6 - Clockwise rotation (normal) - method b

A different way of looking at the SAME phasing.

Turn your engine to 60 BTDC. Mount the VR sensor wherever is convenient and mount trigger disc so that the center of the sensor aligns with the center of the missing tooth.

EDIS6

This shows another view of the **same** sensor to missing-tooth alignment. When the missing tooth is lined up with the sensor the engine is at 60 BTDC

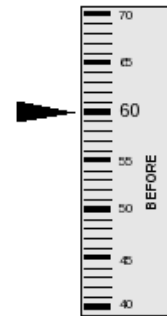
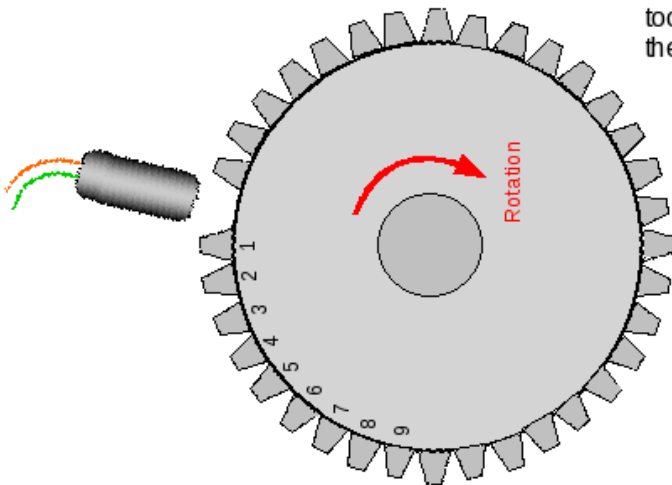

Timing marks on damper

Clockwise rotation

6.7.4.5 EDIS8 - Clockwise rotation (normal) - method a

Set your engine at TDC, then put the missing tooth 5 teeth earlier (more clockwise) than the sensor. This will put the center of a tooth central to the sensor.

EDIS8 - 5 teeth offset

With engine at TDC, the VR sensor aligns with the 5th tooth

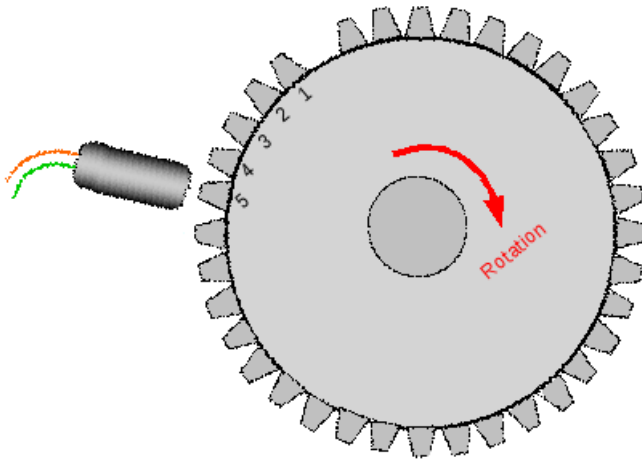

Timing marks on damper

Clockwise rotation

6.7.4.6 EDIS8 - Clockwise rotation (normal) - method b

Turn your engine to 50 BTDC. Mount the VR sensor wherever is convenient and mount trigger disc so that the center of the sensor aligns with the center of the missing tooth.

EDIS8

This shows another view of the **same** sensor to missing-tooth alignment. When the missing tooth is lined up with the sensor the engine is at 50 BTDC

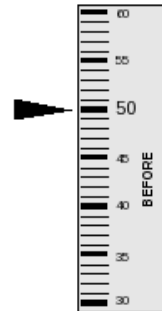
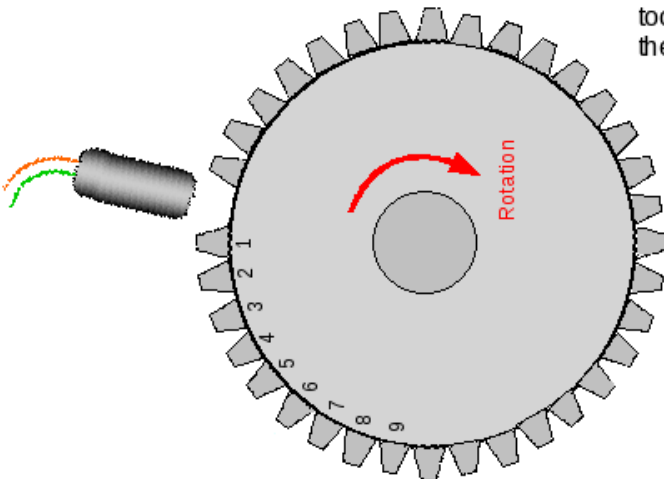

Timing marks on damper

Clockwise rotation

6.7.4.7 EDIS4 anti-clockwise

Anti-clockwise rotation.
The same applies, but directions are reversed.

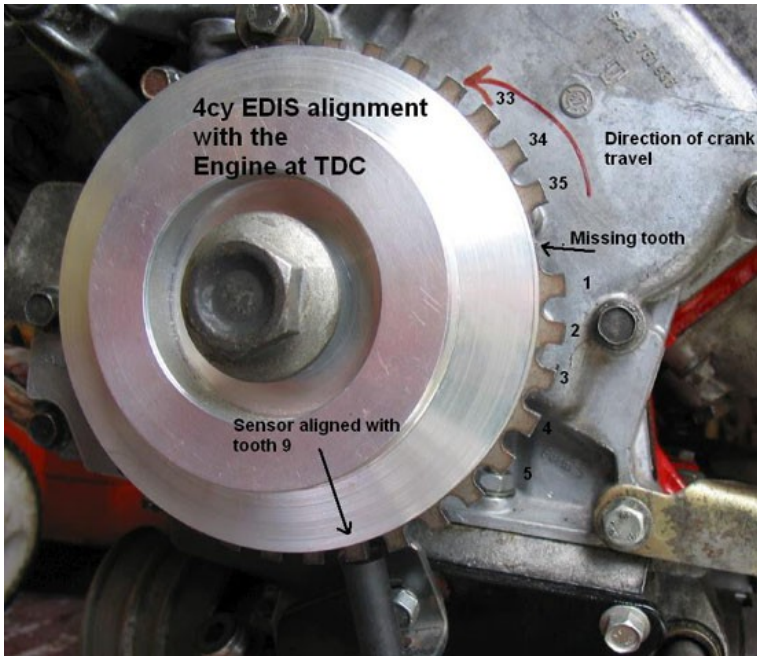

6.7.5 Checking the timing

As with all installs, it is important to confirm the timing is correct. To test this it is best to first run the EDIS in limp home mode. This can be achieved by disconnecting the SAW plug/socket or switching off/unplugging the ECU. Fit your strobe onto no.1 plug lead as normal (you may need to try the other tower of the pair).

A dumb strobe is advised, or use a strobe that is compatible with wasted-spark or 2-stroke.

Ensure EDIS still has power and crank your engine, check that the timing is exactly 10deg. If not, adjust your sensor until it is. It is safe to idle the engine with the SAW lead disconnected, timing should be rock solid at 10BTDC. Don't forget to reconnect the plug when done!

Now that you have confirmed that the EDIS is correctly running at 10BTDC base timing, you need to check that ECU is correctly commanding timing on the EDIS.

Start the engine and then on the Ignition settings menu on your tuning computer, select "Fixed Timing" and enter 15 BTDC, check that you strobe 15 BTDC on the crank.

When done, return the setting to "Use table" and Burn.

6.8 GM DIS (for reference only)

As far as the ECU is concerned, GMDIS works similarly to HEI7. Even though the module is controlling wasted spark ignition, the ECU does not receive any cylinder identification or phase information.

The same internal modifications are required as for HEI7 in section 6.4

This wiring need confirming.

P = Positive from VR sensor

N = Negative from VR sensor

G = Ground to Megasquirt Sensor ground

B = Bypass from Megasquirt SPR3

R = Reference (REF) to Megasquirt Tach in.

E = Electronic spark timing (EST) from Megasquirt IGN (36)

GMDIS General layout

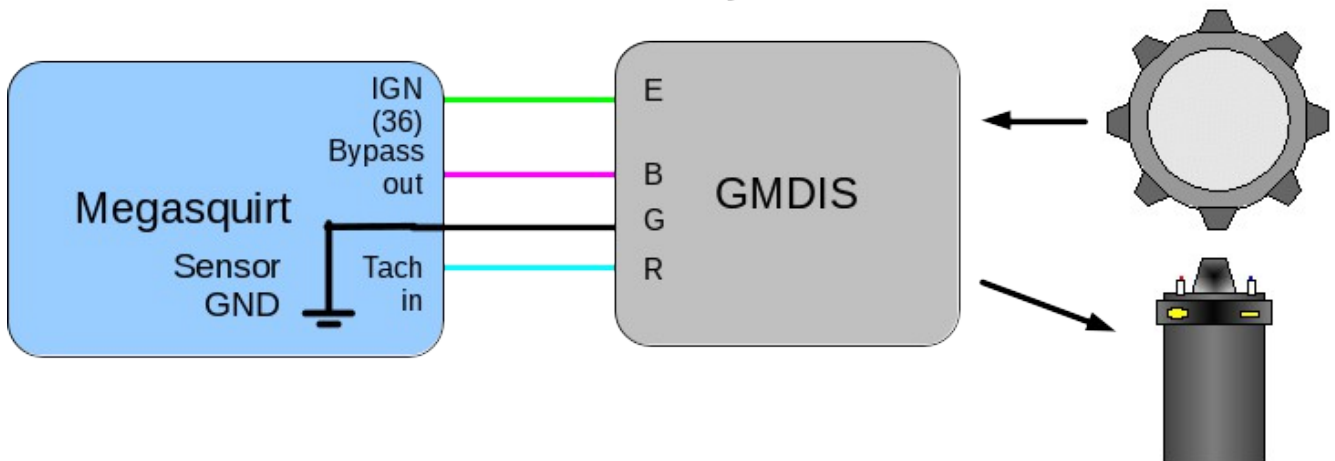

These settings need confirming.

Ignition capture = "Falling" (check!)

Spark output = "Going High" (check!)

Spark A output pin = "D14"

Dwell type = "Standard Dwell"

Nominal Dwell = "3.0"

GM/HEI options = "GM bypass"

6.9 Toothed Wheel

The Toothed Wheel mode is designed to support most combinations of regular missing tooth wheels with or without a cam signal. It is the most commonly used "spark mode" for tach input.

Various spark outputs (single coil, wasted spark, coil-on-plug) are supported by Toothed Wheel, the table in section 6.9.1 shows possible options. See section 5.3 for ignitor, coil and wiring examples.

Other irregular OEM specific wheel patterns (e.g. 420A, 4G63, LS1) have their own spark modes which are covered in later sections.

6.9.1 Wheel combinations

The table below lists all of the valid combinations for trigger wheel. However some of the modes will rarely be used. The most common are:

36-1 on crank - many Fords

36-1 on crank plus single tooth cam sensor - same

60-2 on crank - many vehicles with Bosch ECU, BMW, VW, Audi, Volvo, Vauxhall, Opel, Peugeot etc.

60-2 on crank plus single tooth cam sensor - same

24 tooth on cam - many Japanese originated vehicles use the Nippondenso 24 tooth CAS with differing numbers of 2nd trigger teeth and sensors.

Note - this table is for four-stroke piston engines. Two stroke or rotaries only need 360 degrees of information for full sequential and COP.

Commonly used modes have detailed sections on how to set them up. Unusual modes are not documented in detail at this time.

Physical wheels		Supports							Settings		
Main wheel	Secondary wheel	Single coil	Wasted spark	Wasted-COP	COP	Batch/bank fire	Semi-seq	Seq.	Trigger wheel arrangement	Main wheel speed	2nd trig every rotation of
Missing tooth on crank	None	Y	Y	Y	N	Y	Y	N	Single wheel with missing tooth	Crank	n/a
Missing tooth on cam	None	Y	Y	Y	Y	Y	Y	Y	Single wheel with missing tooth	Cam	n/a
Missing tooth on crank	Single tooth on cam	Y	Y	Y	Y	Y	Y	Y	Dual wheel with missing tooth	Crank	n/a
Missing tooth on crank	LS2 4X, VW 2 wide/narrow or half-moon on cam	Y	Y	Y	Y	Y	Y	Y	Dual wheel with missing tooth	Crank	n/a
Non-missing tooth on crank	Single tooth on crank	Y	Y	Y	N	Y	Y	N	Dual wheel	Crank	Crank
Non-missing tooth on crank	Single tooth on cam	Y	Y	Y	Y	Y	Y	Y	Dual wheel	Crank	Cam
Non-missing tooth on crank	Cam wheel with tooth per cylinder	Y	N	N	N	Y	N	N	Dual wheel	Crank	Every Cylinder
Non-missing tooth on cam	Single tooth on cam	Y	Y	Y	Y	Y	Y	Y	Dual wheel	Cam	Cam
Non-missing tooth on cam	Single tooth on crank or two opposite teeth on cam	Y	Y	Y	N	Y	Y	N	Dual wheel	Cam	Crank
Non-missing tooth on cam	Cam wheel with tooth per cylinder	Y	N	N	N	Y	N	N	Dual wheel	Cam	Every Cylinder

For initial setup and determining tooth#1 angle on uncommon setups having timing marks or tape on your crank pulley/damper covering the full 360 degrees will be greatly helpful. Speed shops sell timing tape for a variety of damper diameters. If your engine has no timing marks you do need to add them. Just guessing at timing is a great way to damage an engine.



It is essential that ignition timing is confirmed with a timing-light on EVERY install.

Running excessive timing under load will almost always cause severe engine damage. Ignore this warning at your peril !

6.9.2 Terminology notes

Missing tooth - This is a regular wheel with a group of "missing" teeth e.g. 12-1, 36-1, 36-2, 60-2

on crank - the wheel is rotating at crank speed, normally directly attached to the crank pulley or flywheel

on cam - the wheel is rotating at camshaft or distributor speed

Single coil - a single coil and distributor

Wasted spark - double ended coils (or a pair of coils) that fire twice per cycle

Wasted-COP - a single coil per cylinder, but firing twice per cycle

COP - a single coil per cylinder that fires once per cycle

Batch/bank fire - groups of injector fired at once, not timed to a specific cylinder event

Semi-sequential - injectors fired twice per cycle timed to cylinder events

Sequential - each injector fires once per engine cycle timed to a specific cylinder event

6.9.3 Wheel naming

There does not appear to be universal agreement on the way to name wheels, however in the Megasquirt world, they will be named like the following examples.

36-1. This means a single wheel with place for 36 teeth and a single tooth omitted. i.e. 35 teeth at 10 (360/36) degree spacing.

36-2. This means a single wheel with place for 36 teeth and a two adjacent tooth omitted. i.e. 34 teeth at 10 (360/36) degree spacing.

36-1-1. This means a single wheel with place for 36 teeth and a two non-adjacent single tooth omitted. This type of wheel is not supported by "toothed wheel" - it is supported as Rover#1

36-2-2-2. This means a single wheel with place for 36 teeth and a three sets of double missing teeth. This type of wheel is not supported by "toothed wheel" - it is supported as 36-2-2-2 with the specific OEM pattern built into the decoder.

24/1. This means 24 teeth (non-missing) on one wheel and a single tooth on a second wheel.

36-1/1. This means a one 36-1 wheel and a single tooth on a second wheel.

3+1. This means one wheel with 3 equally spaced teeth and an additional tooth to indicate sync. (Supported somewhat as Daihatsu 3cyl)

Spark Mode - set to "Toothed Wheel"

Trigger Angle/Offset - always zero

Angle between main and return - n/a

Oddfire small angle - for oddfire engines this specifies the smallest of the crank angles between ignition events

GM HEI/DIS options - n/a

420A/NGC alternate cam - n/a

Use cam signal if available - n/a

Oddfire phasing - usually "Alternate" but for Vmax use "Paired"

Skip pulses - number of input pulses at startup that are ignored before decoding begins. Safe to leave at 3.

Ignition Input Capture - see ignition page

Spark output - see ignition page

Number of coils - see ignition page

Spark hardware in use - see ignition page

Cam input - see ignition page

Trigger wheel arrangement - see table above for correct settings

Trigger wheel teeth - the number of effective teeth, counting the missing teeth as if they existed. i.e. a 36-1 wheel has 35 physical teeth, but enter 36.

Missing Teeth - the number of missing teeth. Common are 1 for 36-1, or 2 for 60-2 or 36-2

Tooth #1 angle - definition depends on whether main wheel is missing or non-missing type. See sections below.

Main wheel speed - Does the main wheel rotate at crankshaft speed or camshaft (distributor) speed.

Second trigger active on - Like ignition input capture above, specifies which voltage level is considered "active"

Level for phase 1 - only applies in "Poll level" mode. See Dual+Missing section.

and every rotation of - how often are second trigger input pulses received. See Dual Wheel section

All of the settings on the right hand side of the page are general and will be covered in the Ignition manual.

There are two main categories of install - Retrofit and Existing.

6.9.4 Retrofit install

If you have an engine that did not originally come equipped with a trigger wheel (e.g. a distributor based, pre-EFI engine) then you have to mount a wheel and sensor and set the phasing correctly.



Suggestion for a typical car engine

Install a 36-1 wheel on the crank for accurate wasted spark ignition and batch-fire fuel.

For installs requiring COP or sequential fuel, install a 36-1 wheel on the crank and a 50/50 cam tooth with gear-tooth hall sensor.

60-2 works great on most engines too, but is not advised for very high rpms.

For very high revving engines (such as motorcycle engines) due to the number of teeth per second, 36-1, 24-1 or 12-1 are preferred.

While the code can cope with any sensor/tooth phasing, during cranking the rpms vary up and down greatly as the engine rotates. It is desirable to place the missing tooth such that it passes the sensor when the engine speed is somewhat stable or it may be impossible for the ECU to "see" the missing tooth. The OEMs have found that certain tooth#1 angles work well and it is worth following their lead.

It is **suggested** to align your wheel and sensor to arrive at the following tooth #1 angles.

4 cylinders ~90-120 deg

6 cylinders ~50 deg

8 cylinders ~40 deg

Take a look at Appendix B pages for places to source used trigger wheels, sensors and coilpacks. Note that you do NOT need the EDIS module, so later ('internal-EDIS') cars are useful donors too.

Mounting the wheel is quite critical in that it MUST be mounted so it rotates without moving up, down, left or

right as the sensor needs to see all of the teeth with a gap of 0.75 - 1.0mm.

The tooth size needs to be matched to the sensor. Make sure that the sensor is designed to operate with the tooth size on your wheel. If using an OEM part, then stick to the sizes that they used.

Very long single teeth, as used on some bike flywheels are not readily supported - consider retrofitting a toothed wheel instead.

Having mounted the wheel and sensor, you can proceed for an existing install.

6.9.5 Existing install

In this cases where you are fitting Megasquirt to an engine already fitted with a trigger wheel, your main task is to wire up the sensor(s), determine the tooth #1 angle and wire up your coil(s). It should not normally be necessary to modify the trigger wheels.

6.9.6 Missing tooth crank wheel

This is a very common configuration for wasted spark with the most typical wheels being 36-1 (Ford) and 60-2 (Bosch.) Note that the missing teeth are in a single group - if your wheel has multiple groups then you need a special wheel decoder. Many custom decoders already exist e.g. 36-2-2-2 and the one matching your wheel must be used instead of this generic "toothed wheel" mode.

The software benefits from a reasonable number of teeth (hence 36 or 60) for best ignition timing accuracy. Low tooth count wheels such as 4-1 are not advised.

What is Tooth #1

With the engine rotating in the normal direction...

Tooth #1 is the first tooth to pass the sensor after the missing tooth gap.

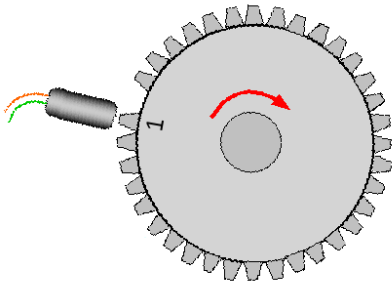

We use the term "tooth#1" as it is consistent across wheels with one, two, three or four missing teeth in the group.

Once the software knows the tooth#1 angle it automatically calculates other needed information internally.

The following table shows examples, in this case the tooth#1 angle happens to be 80 degrees.

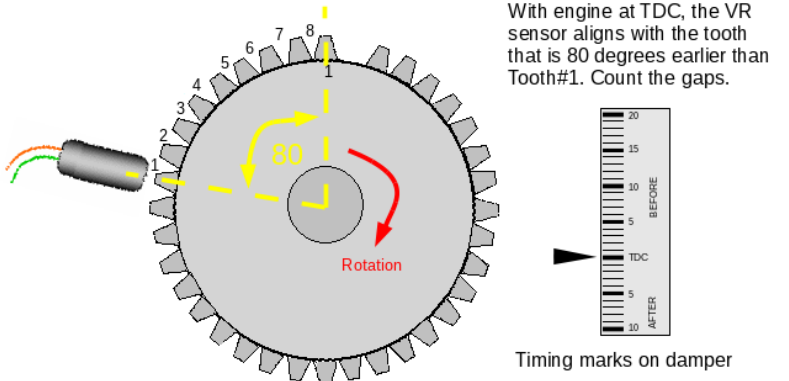
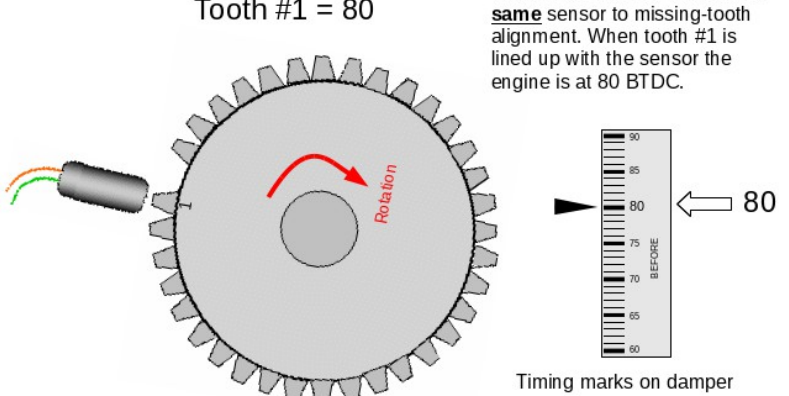
<p>Clockwise rotation (normal) - method a</p> <p>Set your engine at TDC, then count the number of GAPS to tooth#1 in the direction of rotation (clockwise here) and multiply by the angular size of the tooth. e.g. 8 teeth * 10 deg/tooth = 80 deg</p> <p>36-1 wheels are 10 deg per tooth 60-2 wheels are 6 deg per tooth 24-2 wheels are 15 deg per tooth</p>	<p>Tooth #1 = 80</p>  <p>With engine at TDC, the VR sensor aligns with the tooth that is 80 degrees earlier than Tooth#1. Count the gaps.</p> <p>Timing marks on damper</p> <p>Clockwise rotation</p>
<p>Clockwise rotation (normal) - method b</p> <p>A different way of looking at the SAME phasing.</p> <p>Turn your engine so that tooth #1 aligns with the sensor.</p> <p>Read off the tooth#1 angle from timing marks/tape on the crank pulley.</p>	<p>Tooth #1 = 80</p>  <p>This shows another view of the same sensor to missing-tooth alignment. When tooth #1 is lined up with the sensor the engine is at 80 BTDC.</p> <p>Timing marks on damper</p> <p>Clockwise rotation</p>

Typical settings:

- Spark mode = Toothed wheel
- Trigger angle/offset = 0 (not used in toothed wheel mode)
- Trigger wheel arrangement = Single wheel with missing tooth
- Trigger wheel teeth = number of teeth including missing teeth (e.g. 36, 60 etc.)
- Missing teeth = number of missing teeth (e.g. 1, 2)
- Tooth #1 angle = tooth #1 angle as determined above
- Main wheel speed = Crank wheel

Common combinations:

- Ford 4 cyl = 36-1, 80deg tooth #1
- Ford 6 cyl = 36-1, 50deg tooth #1
- Ford 8 cyl = 36-1, 40deg tooth #1
- Bosch 4 cyl (Peugeot, Vauxhall) = 60-2, 114 deg tooth #1

6.9.7 Missing tooth cam wheel

This arrangement is not commonly used by OEMs but does support full sequential with a single wheel and sensor. Cam triggering is less accurate than crank triggering due to timing belt or chain stretch.

The software benefits from a reasonable number of teeth (hence 36 or 60) for best ignition timing accuracy. Low tooth count wheels such as 8-1 are not advised.

The previous section on missing tooth crank wheel generally applies when the wheel is mounted to the cam, but remember that one rotation of the cam is 720 crank degrees. The settings are in crank degrees. So a tooth#1 that is 8 gaps earlier than the sensor on a 36-1 wheel would give a 160deg tooth#1 angle ($8 * 10 * 2$ [for cam])

Typical settings:

Spark mode = Toothed wheel

Trigger angle/offset = 0 (not used in toothed wheel mode)

Trigger wheel arrangement = Single wheel with missing tooth

Trigger wheel teeth = number of teeth including missing teeth (e.g. 36, 60 etc.)

Missing teeth = number of missing teeth (e.g. 1, 2)

Tooth #1 angle = tooth #1 angle as determined above

Main wheel speed = Cam wheel

6.9.8 Missing tooth crank wheel and single tooth cam wheel

This is a very common arrangement that supports full sequential and coil on plug.

(For 50/50 half-moon or 4-window wide/narrow or other polled cam wheels see section 6.9.9)

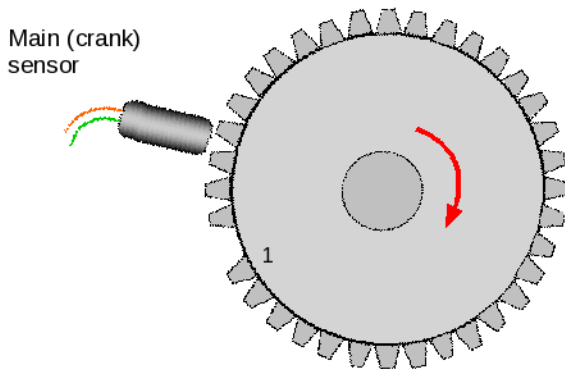
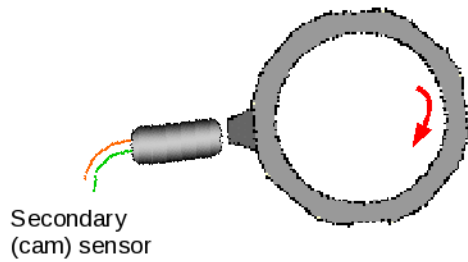

The definition of tooth#1 is the same as the basic missing tooth crank wheel and should be phased in the same way. Ensure you also read the section above. The cam input tells the code which engine cycle/phase it is on. From the crank wheel alone the code knows when cylinder one is at TDC, but it cannot distinguish TDC compression or TDC exhaust. The cam sensor adds this information which is why it needs to be one pulse only per engine cycle.

The cam signal is a single pulse usually generated by a narrow tooth, vane or window. During setup, you will need to use the composite logger in TunerStudio to verify the phasing between the crank and cam signals is acceptable.

To confirm correct cam sensor phasing proceed as follows. (Note that some engines should not be rotated backwards, use tape or pen marks on the pulleys or sprockets to remember positions and rotate forwards only.)

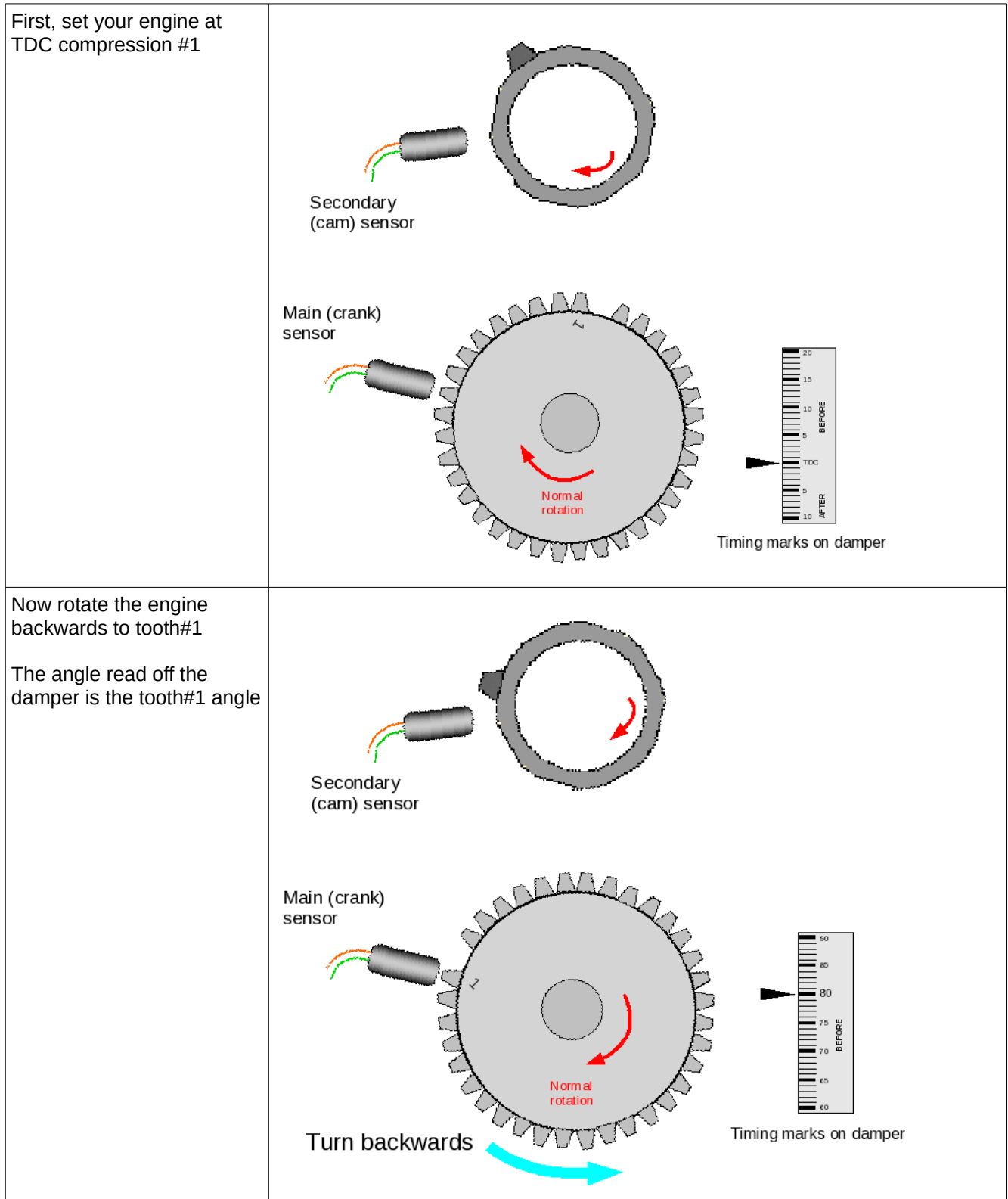

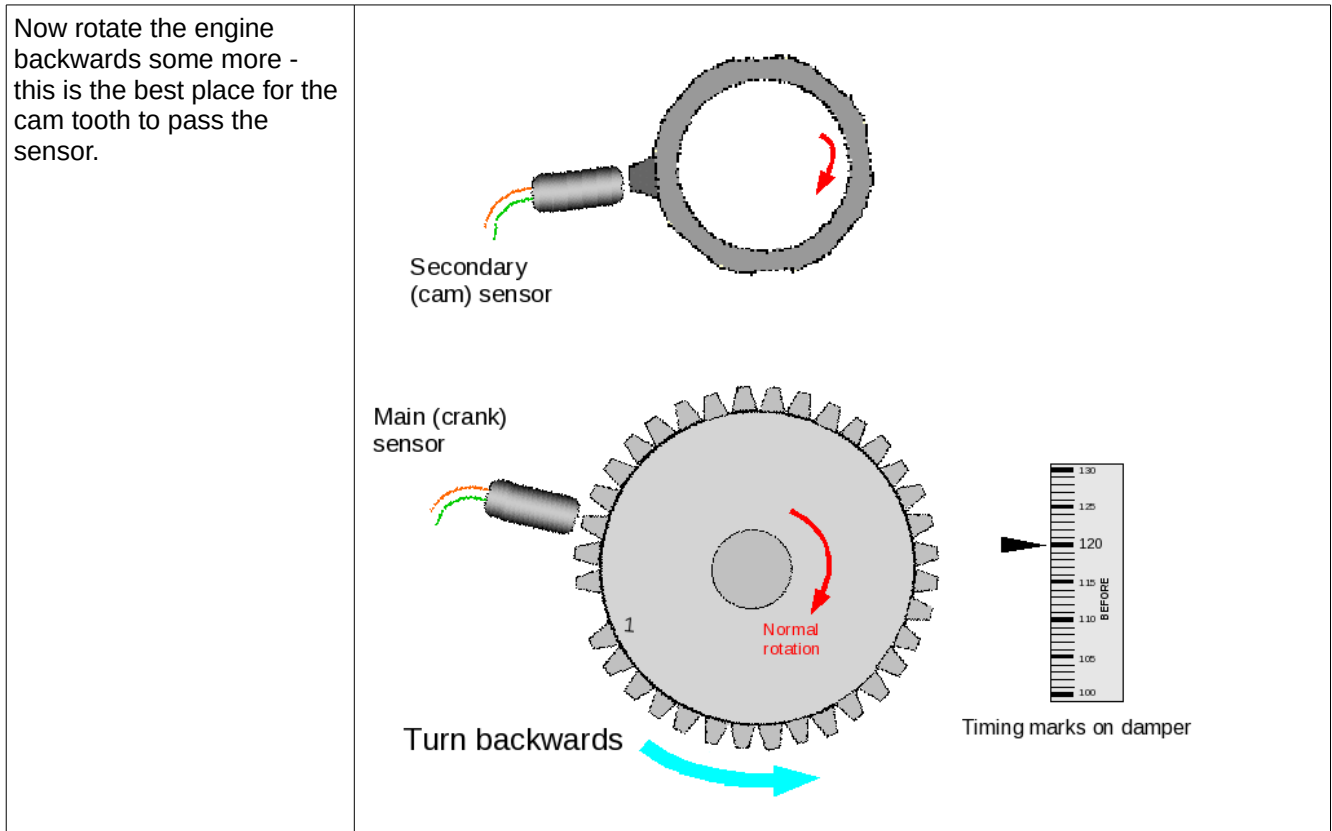

Typical settings:

- Spark mode = Toothed wheel
- Trigger angle/offset = 0 (not used in toothed wheel mode)
- Trigger wheel arrangement = Dual wheel with missing tooth
- Trigger wheel teeth = number of teeth including missing teeth (e.g. 36, 60 etc.)
- Missing teeth = number of missing teeth (e.g. 1, 2)
- Tooth #1 angle = tooth #1 angle as determined above
- Main wheel speed = Crank wheel
- Second trigger active on = Rising edge (confirm with composite logger)

6.9.9 Missing tooth crank wheel and polled cam wheel

This is a fairly common arrangement that supports full sequential and coil on plug. Here a missing tooth wheel is used on the crank in the common way and a hall-effect or gear-tooth sensor is used on the cam with a long tooth or window or vane. This gives you the ability to have full sequential, but the engine syncs up as fast as a regular missing tooth crank wheel.

Different OEM implementations exist - some engines use a 50/50 cam pattern, Vauxhall red-top engines use a window in the distributor rotor that spans the missing tooth region. Many newer engines with Bosch ECUs utilize a 4 tooth wide/narrow cam trigger, this is used on some VW, GM LS2, LS4 and some Mercedes. As far as the code is concerned these are equivalent because it only 'looks at' (polls) the cam just after the missing tooth to determine engine phase.

The wide/narrow type is used for VVT control on some engines, this is not supported with Megasquirt-2.

Typical polled cam triggers:

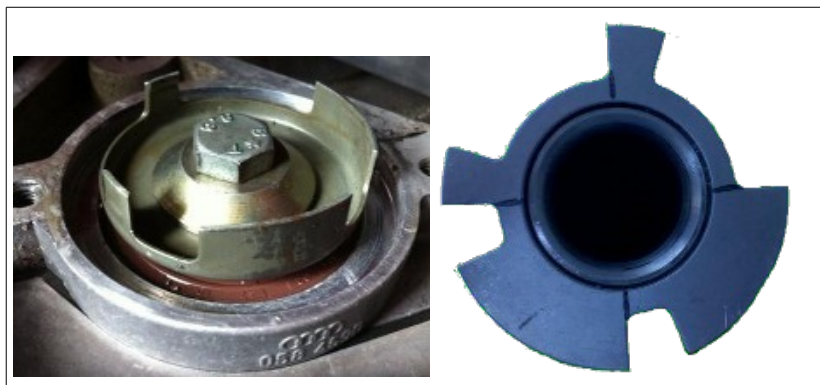
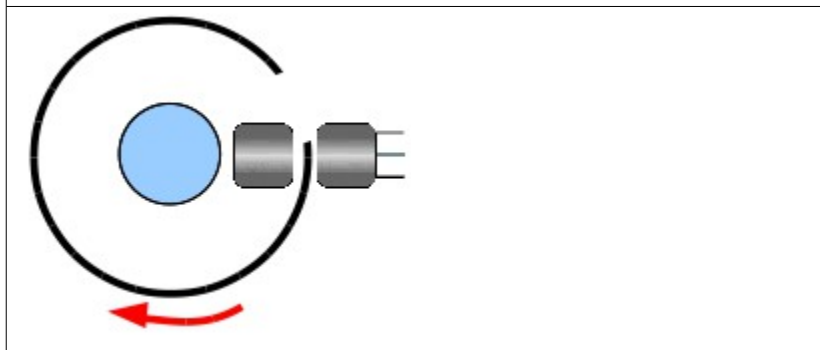
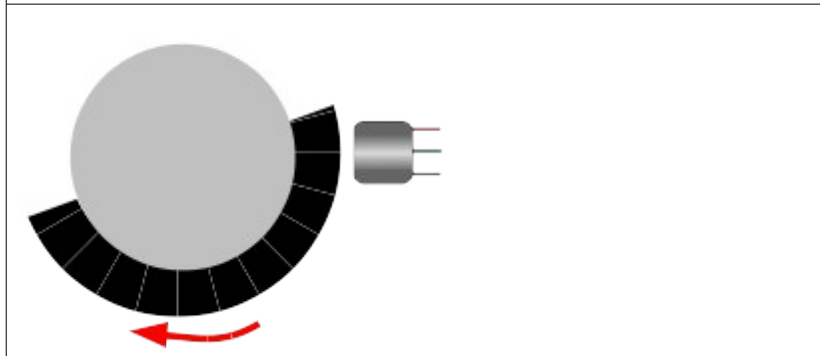
 A photograph on the left shows a metal cam trigger with four teeth mounted on a shaft. To its right is a 3D CAD model of the same part, colored blue, showing its circular shape and four protruding teeth.	<p>4 tooth wide/narrow type e.g. GM LS2 4X / VW / Mercedes</p>
 A schematic diagram showing a circular vane cup with a single window. A blue circle represents the window. A grey shaft with three pins is shown on the right. A red curved arrow at the bottom indicates counter-clockwise rotation.	<p>Vane cup with single window e.g. 1 window Bosch dizzy in Vauxhall red-top.</p>
 A schematic diagram of a half-moon cam trigger. It consists of a grey circular base with a black semi-circular segment on the right side, divided into several radial segments. A grey shaft with three pins is on the right. A red curved arrow at the bottom indicates counter-clockwise rotation.	<p>Half-moon type</p>

General arrangement

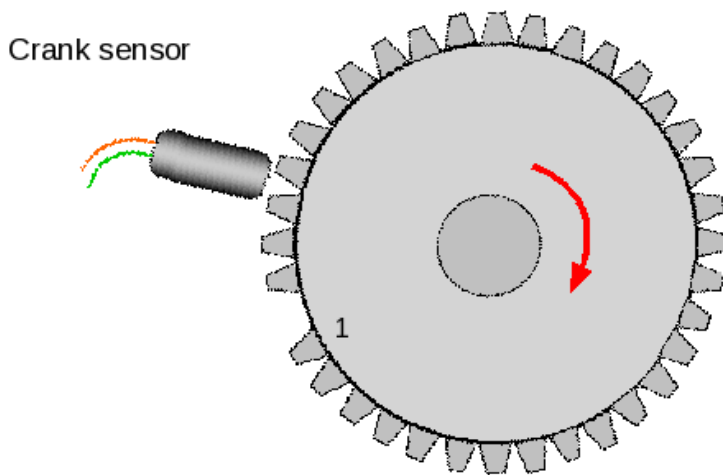
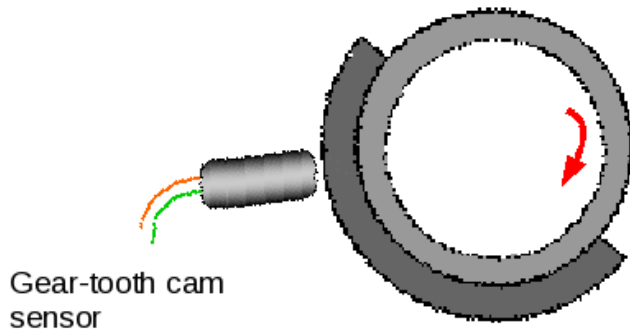

The definition of tooth#1 is the same as the basic missing tooth crank wheel and should be phased in the same way. The cam input tells the code which engine cycle/phase it is on. From the crank wheel alone the code knows when cylinder one is at TDC, but it cannot distinguish TDC compression or TDC exhaust. The cam sensor adds this information.

At close to tooth#1 the code examines the voltage level on the input to determine which phase it is on - the 'tooth' should normally start at least 20 crank degrees before tooth#1 and continue for another 20 crank degrees afterwards. (The level is actually polled at tooth#2.)

The additional teeth on the long/short cam wheel do not matter.

To confirm correct cam sensor phasing proceed as follows.

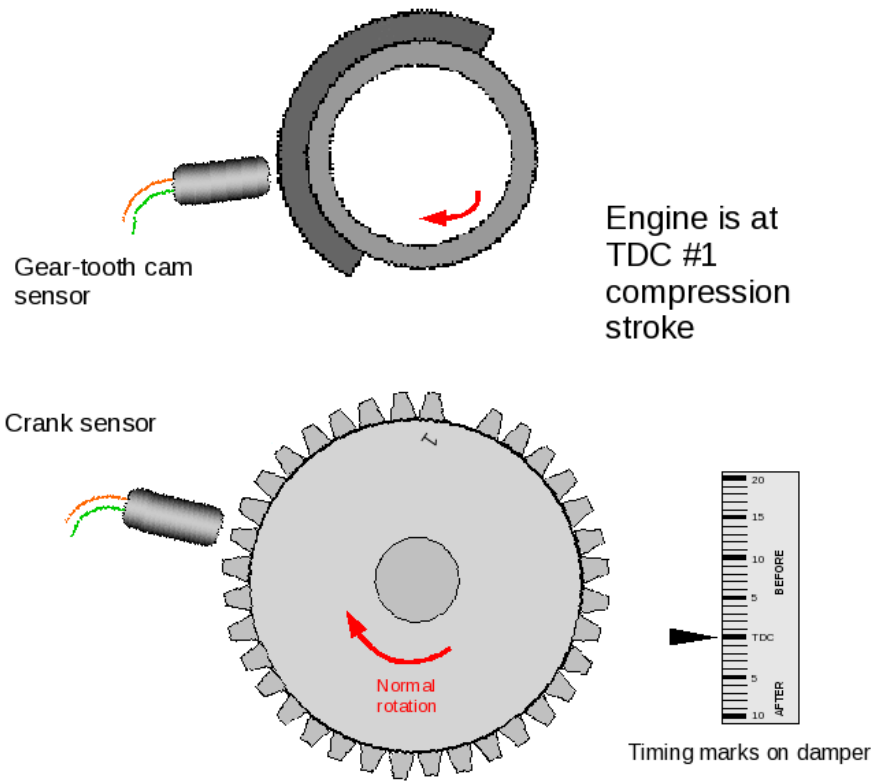
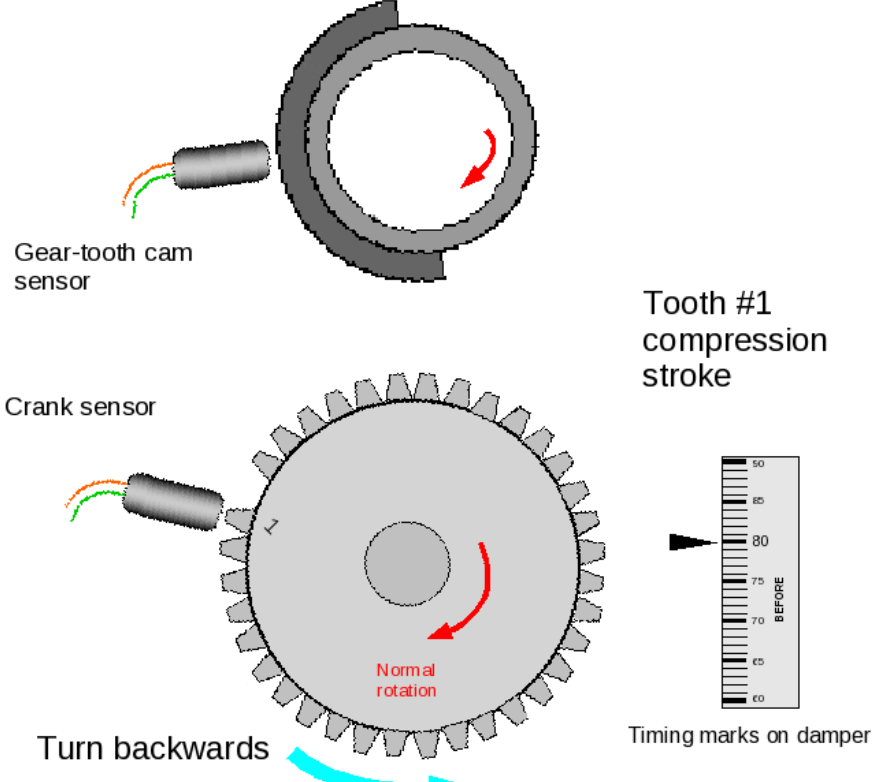
<p>First, set your engine at TDC compression #1</p>	 <p>Gear-tooth cam sensor</p> <p>Engine is at TDC #1 compression stroke</p> <p>Crank sensor</p> <p>Normal rotation</p> <p>Timing marks on damper</p>
<p>Now rotate the engine backwards to tooth#1</p> <p>The cam sensor should be roughly in the middle of window/tooth/vane</p> <p>With the cam sensor powered and connected to the Megasquirt measure the output voltage.</p> <p>A voltage of ~0V here requires the HIGH setting and a voltage of ~5V here requires the LOW setting. ???? Check ????</p>	 <p>Gear-tooth cam sensor</p> <p>Tooth #1 compression stroke</p> <p>Crank sensor</p> <p>Normal rotation</p> <p>Turn backwards</p> <p>Timing marks on damper</p>

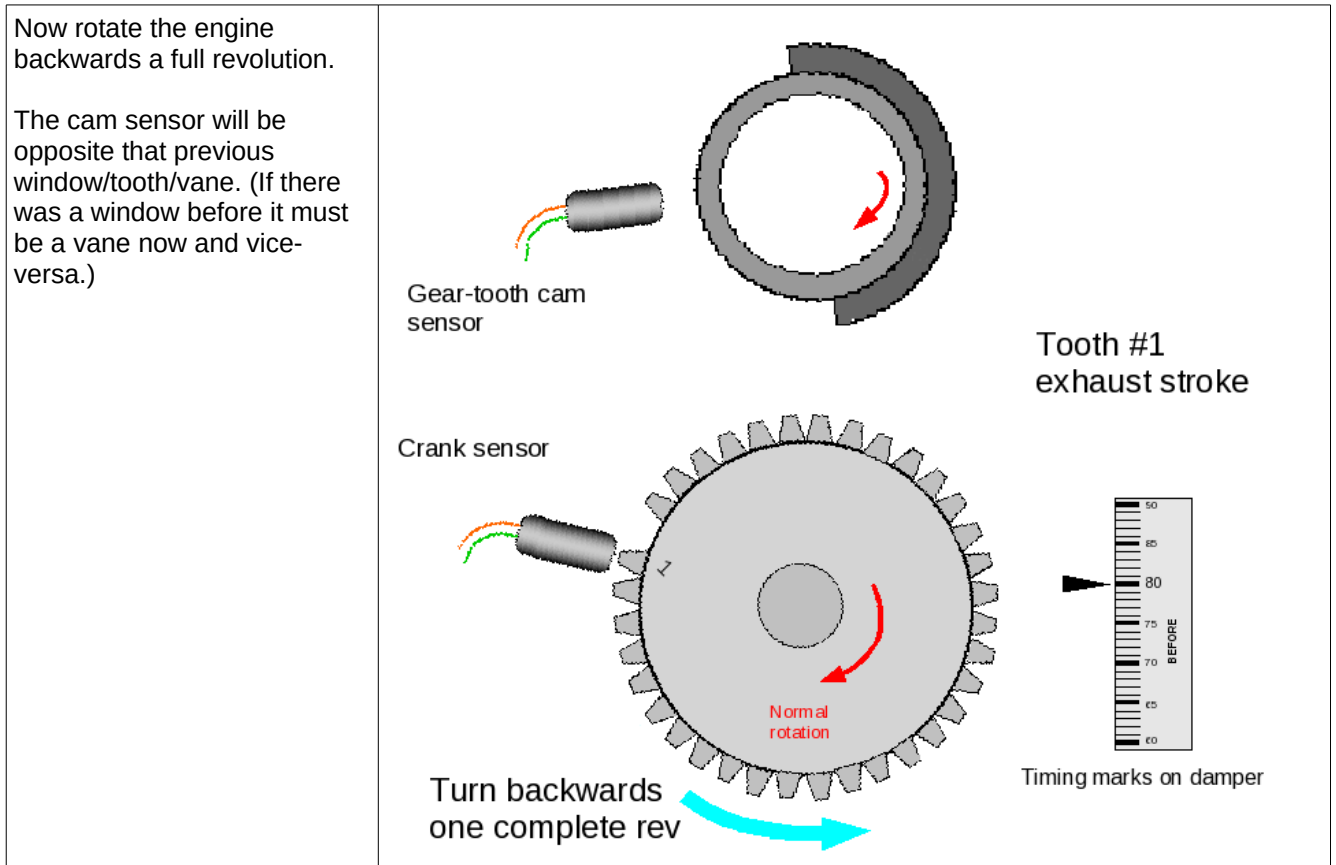

Typical settings:

- Spark mode = Toothed wheel
- Trigger angle/offset = 0 (not used in toothed wheel mode)
- Trigger wheel arrangement = Dual wheel with missing tooth
- Trigger wheel teeth = number of teeth including missing teeth (e.g. 36, 60 etc.)
- Missing teeth = number of missing teeth (e.g. 1, 2)
- Tooth #1 angle = tooth #1 angle as determined above
- Main wheel speed = Crank wheel
- Second trigger active on = Poll level
- Level for phase one = as determined above

6.9.10 Nippondenso CAS

The Nippondenso CAS (crank angle sensor) comes in a number of versions which all use a 24 tooth main wheel and a second wheel with one, two, three or four teeth. There is a single sensor (called Ne) pointing at the 24 tooth wheel and one (G1) or two (G1 and G2) sensors pointing at the second wheel.

This style of CAS is very common on Toyota and Mazda engine from the 1980s and 1990s.

The number of teeth on the second wheel determines whether it can be used (without modification) for single coil distributor, wasted spark or coil-on-plug (COP) and sequential.

The version with a single tooth and two pickup sensors is intended for sequential. The two sensors are used by the OEM to allow the engine to synchronize within one engine revolution. Presently we only support using one of the 'G' sensors.

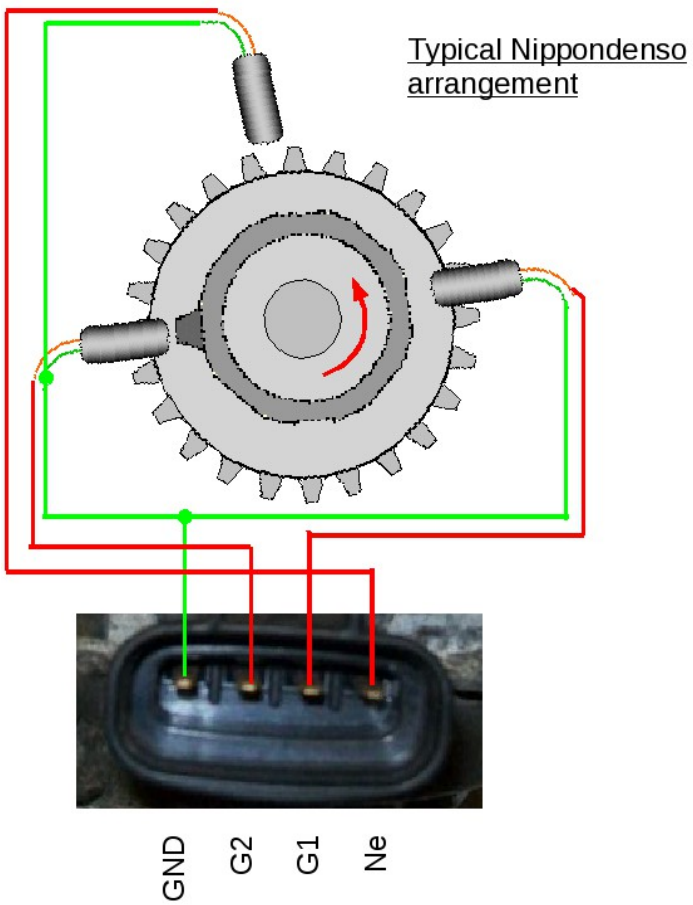

CAS connection	Megasquirt connection
NE- / GND	Pin 2 / GND
Ne	Tach in
G1 or G2	Cam input (mods req'd)
Other G	not used

6.9.10.1 NipponDenso CAS with single G tooth

With the single tooth every 720 degrees this setup gives enough engine information for full sequential fuel and spark.

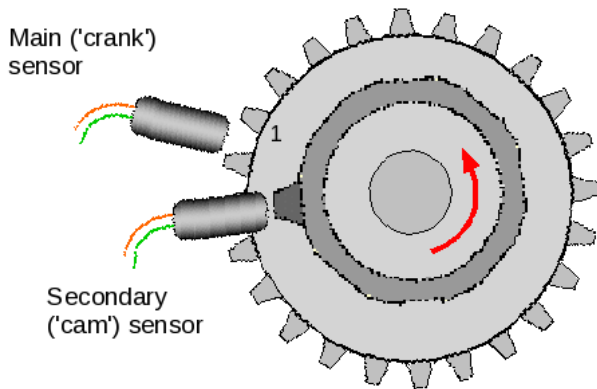

What is Tooth #1

With the engine rotating in the normal direction...

Tooth #1 is the first tooth to pass the main sensor after the single tooth has passed the second sensor.

Make sure these do not happen at the same time - in the diagram you can see that the main sensor is over a gap when the secondary sensor is aligned with its tooth.

First, set your engine at TDC compression #1

Main ('crank') sensor

Secondary ('cam') sensor

Engine is at TDC #1 compression stroke

Timing marks on damper

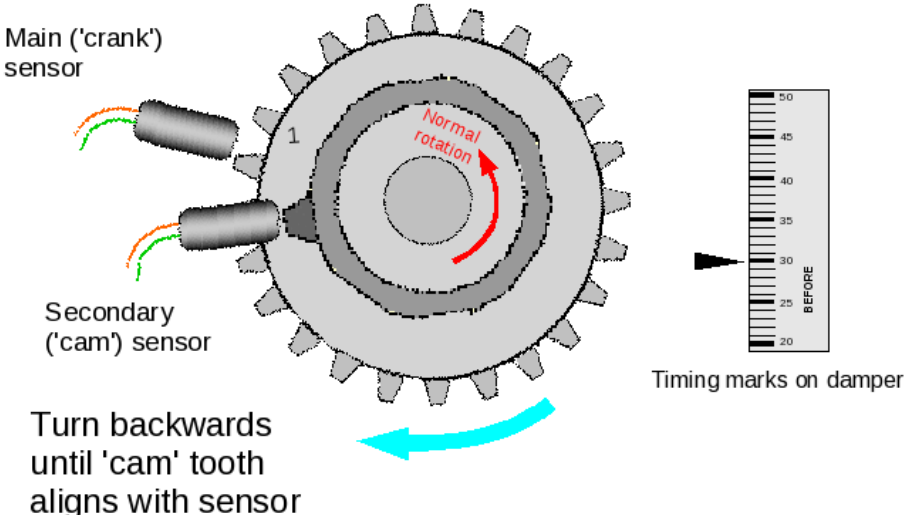
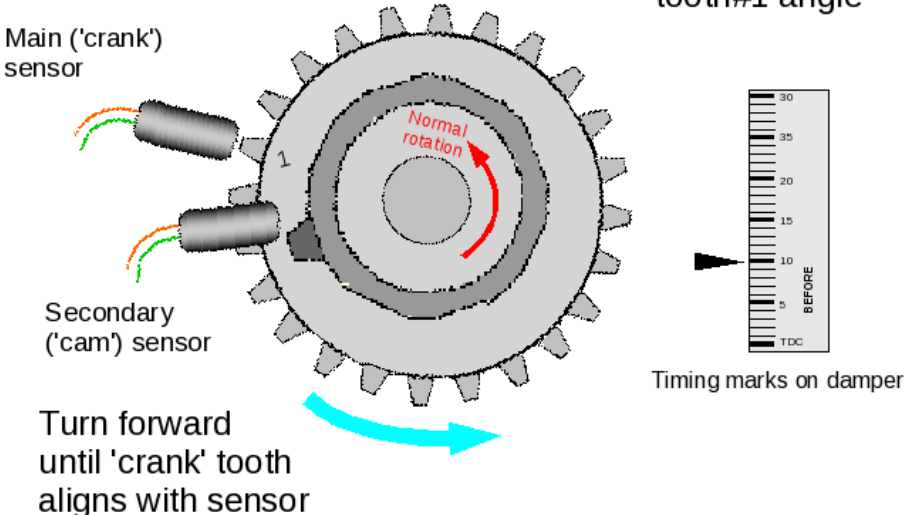
<p>Now rotate the engine backwards until the 'cam' sensor and tooth line up. If you rotated more than one turn, then add 360 to your tooth#1 angle.</p>	 <p>Turn backwards until 'cam' tooth aligns with sensor</p>
<p>Now rotate the engine forwards until the next 'crank' tooth aligns with its sensor. The crank angle now is the tooth#1 angle. (Note that angles shown in diagram are examples only)</p>	 <p>Turn forward until 'crank' tooth aligns with sensor</p> <p>Crank angle is tooth#1 angle</p>

Typical settings:

- Spark mode = Toothed wheel
- Trigger angle/offset = 0 (not used in toothed wheel mode)
- Trigger wheel arrangement = Dual wheel
- Trigger wheel teeth = number of teeth
- Tooth #1 angle = tooth #1 angle as determined above
- Main wheel speed = Cam wheel
- Second trigger active on = Rising (verify with composite logger)
- and every rotation of = Cam

6.9.10.2 NipponDenso CAS with two G teeth

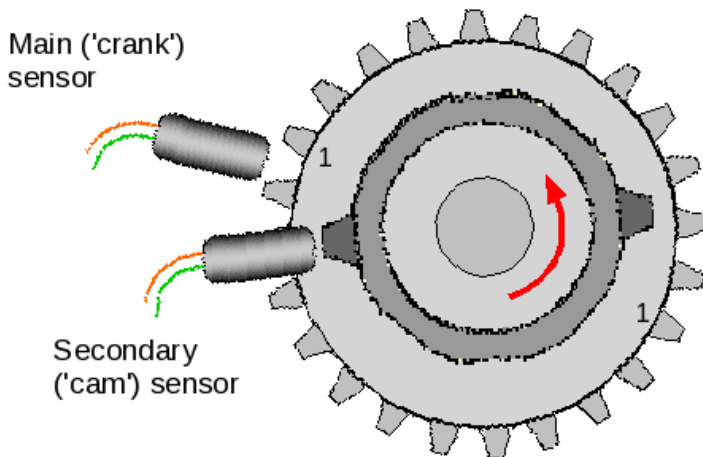

With the cam tooth every 360 degrees this setup gives enough engine information for semi-sequential fuel and wasted spark. (On a rotary such as the RX7, or a two-stroke engine, full sequential fuel and spark is possible as the engine cycle spans 360 degrees.)

What is Tooth #1

With the engine rotating in the normal direction...

Tooth #1 is the first tooth to pass the main sensor after either cam tooth has passed the second sensor.

Make sure these do not happen at the same time - in the diagram you can see that the main sensor is over a gap when the secondary sensor is aligned with its tooth.

Use the instructions in the previous single cam tooth section to determine your tooth#1 angle. It will always be between 0 and 360 degrees.

Typical settings:

Spark mode = Toothed wheel

Trigger angle/offset = 0 (not used in toothed wheel mode)

Trigger wheel arrangement = Dual wheel

Trigger wheel teeth = number of teeth

Tooth #1 angle = tooth #1 angle as determined above

Main wheel speed = Cam wheel

Second trigger active on = Rising (verify with composite logger)

and every rotation of = Crank

6.9.10.3 NipponDenso CAS with three or four G teeth

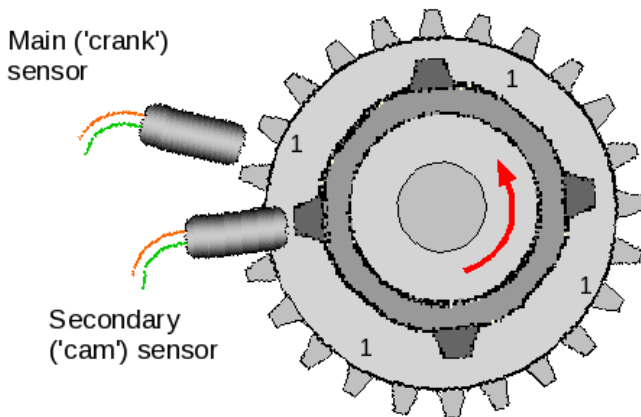

This version is used on three and four cylinder engines with one G tooth per cylinder.

There is only enough position information to run a distributor and untimed injection.

It is not strictly necessary to use both Ne and G wheels. Using both will give you the improved timing accuracy from the 'every-tooth' wheel decoder system, but for simpler installs it is possible to use the 'G' input only and configure as "Basic Trigger" instead. Timing will not be as accurate though.

What is Tooth #1

With the engine rotating in the normal direction...

Tooth #1 is the first tooth to pass the main sensor after either cam tooth has passed the second sensor.

Make sure these do not happen at the same time - in the diagram you can see that the main sensor is over a gap when the secondary sensor is aligned with its tooth.

Use the instructions in the previous single cam tooth section to determine your tooth#1 angle. It will always be between 0 and 360 degrees.

Typical settings:

Spark mode = Toothed wheel

Trigger angle/offset = 0 (not used in toothed wheel mode)

Trigger wheel arrangement = Dual wheel

Trigger wheel teeth = number of teeth

Tooth #1 angle = tooth #1 angle as determined above

Main wheel speed = Cam wheel

Second trigger active on = Rising (verify with composite logger)

and every rotation of = Every cylinder

6.9.11 Non-missing tooth crank wheel with one cam tooth

This arrangement is not commonly used by OEMs but could be used to extend a simple 'distributor' crank trigger

to support sequential. It can also be useful on bike engines with very uneven cranking RPMs that struggle to detect the gap in a missing tooth wheel.

Generally Megasquirt benefits from many crank teeth to improve ignition timing accuracy. However, with this wheel arrangement, you need to beware of trying to use too many teeth on the crank as there is a risk of the trigger inputs overlapping as the cam belt or chain stretches. If this overlap occurs, it will cause sync-loss as the cam tooth moves from being seen "before" to "after" a crank tooth or vice-versa.

12 crank teeth is the suggested maximum.

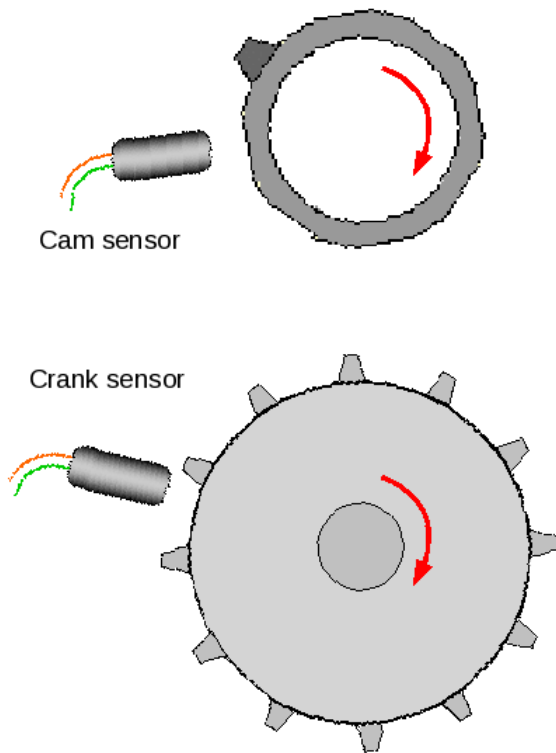

What is Tooth #1

With the engine rotating in the normal direction...

Tooth #1 is the first tooth to pass the main sensor after the cam tooth has passed the second sensor.

Make sure these do not happen at the same time - in the diagrams below you can see that the main sensor is over a gap when the secondary sensor is aligned with its tooth.

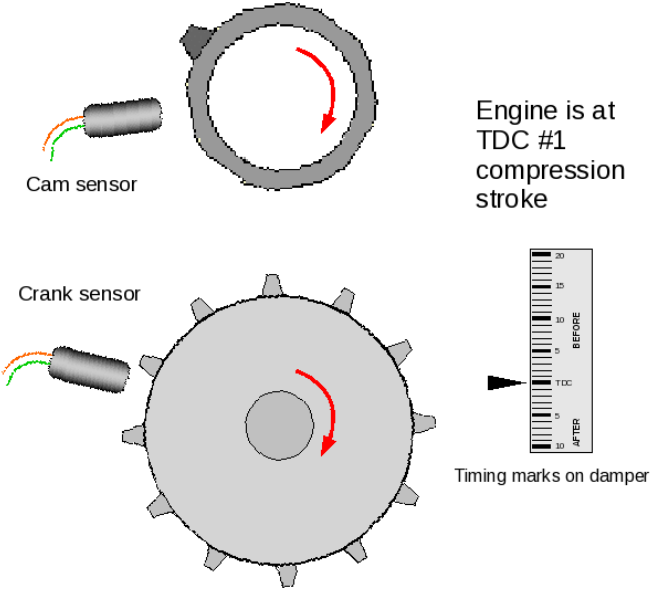
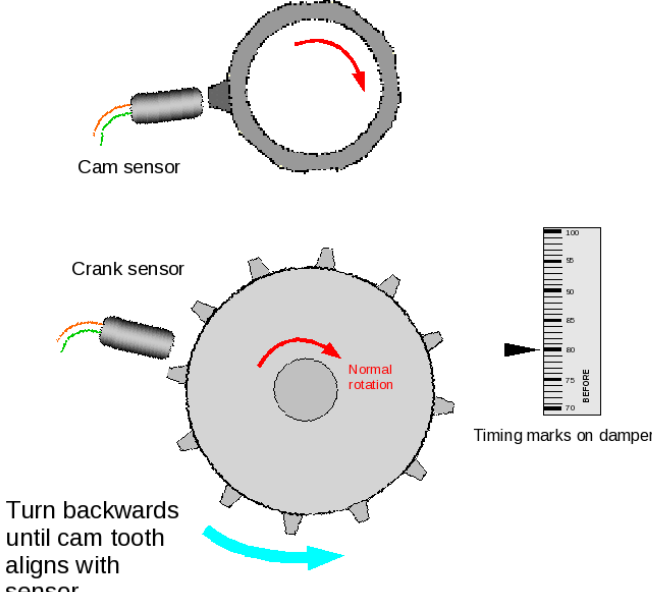
<p>First, set your engine at TDC compression #1</p>	 <p>Cam sensor</p> <p>Crank sensor</p> <p>Engine is at TDC #1 compression stroke</p> <p>Timing marks on damper</p>
<p>Now rotate the engine backwards until the cam sensor and tooth line up. If you rotated more than one turn, then add 360 to your tooth#1 angle.</p>	 <p>Cam sensor</p> <p>Crank sensor</p> <p>Normal rotation</p> <p>Turn backwards until cam tooth aligns with sensor</p> <p>Timing marks on damper</p>

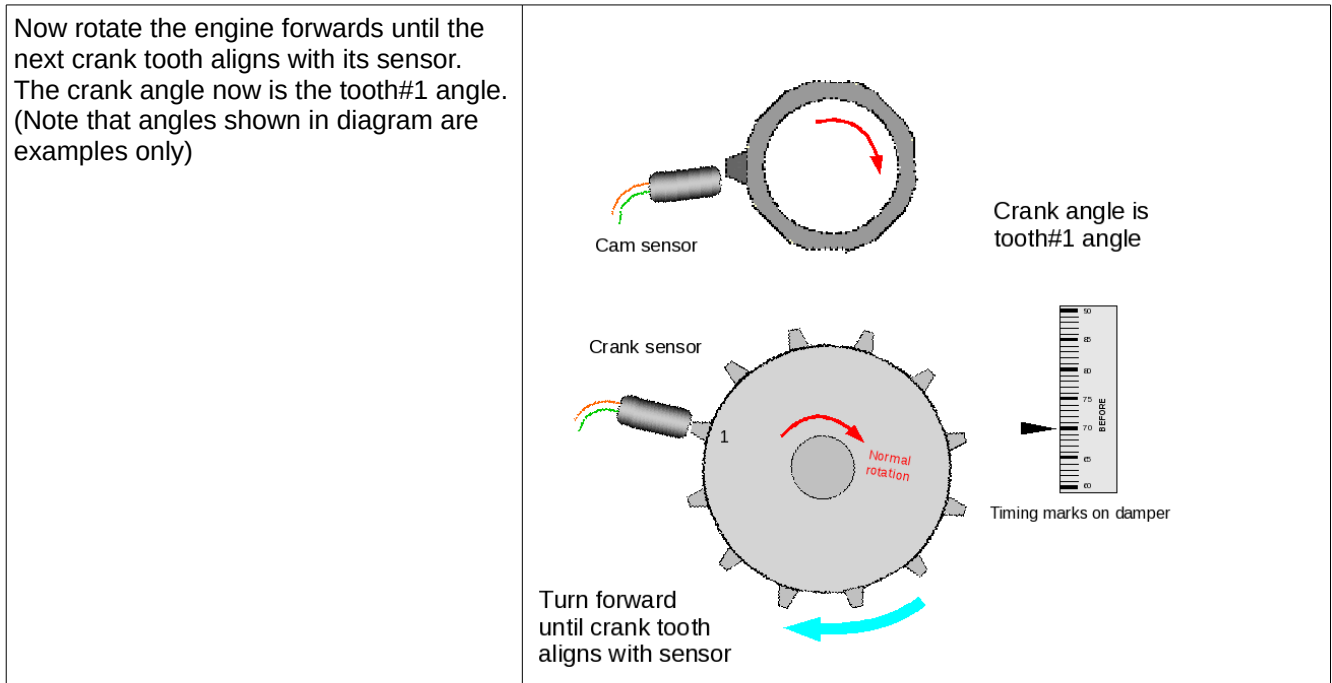

Typical settings:

- Spark mode = Toothed wheel
- Trigger angle/offset = 0 (not used in toothed wheel mode)
- Trigger wheel arrangement = Dual wheel
- Trigger wheel teeth = number of teeth
- Tooth #1 angle = tooth #1 angle as determined above
- Main wheel speed = Crank wheel
- Second trigger active on = Rising (verify with composite logger)
- and every rotation of = Cam

6.9.12 Mitsubishi CAS with aftermarket disc - single coil / wasted spark

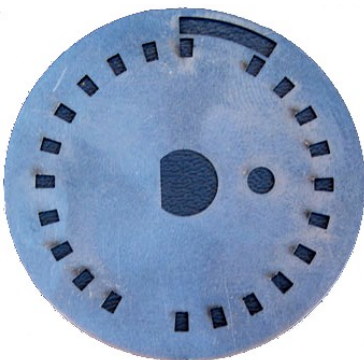

This replacement trigger disc is equivalent to a 12-1 wheel at crank speed with a single pulse on the cam.

The inner signal alone is good enough to run a single coil or distributor.

The addition of the outer single slot signal allows for coil-on-plug or sequential fuel.

Other variants exist.

For single-coil or wasted spark, only the inner track is required.

Set the mainboard as per section 5.2.3

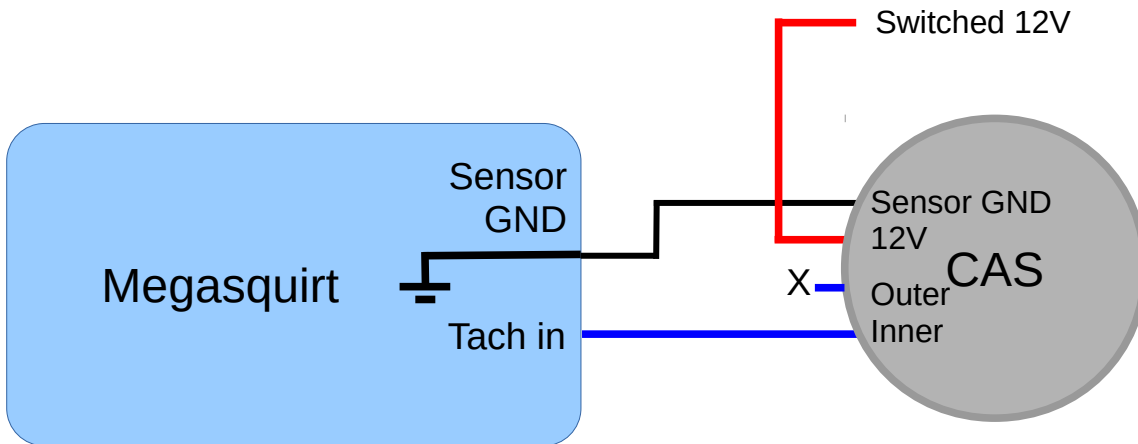

Typical settings:

- Spark mode = Toothed Wheel
- Trigger Angle/Offset = 0 (not used)
- Ignition input capture = ????
- Spark Output = Depends on coils / ignitors
- Number of coils = Wasted Spark
- Trigger wheel arrangement = Single wheel with missing tooth
- Trigger wheel teeth = 12
- Missing teeth = 1
- Tooth #1 angle = 345 (confirm with strobe)
- Wheel speed = Crank wheel

6.9.13 Mitsubishi CAS with aftermarket disc - coil-on-plug

With the same replacement as shown in 6.9.10, both sensor outputs can be wired to allow coil-on-plug. Set the mainboard as per section 5.2.3 and add a cam input as per section 5.2.14.2.

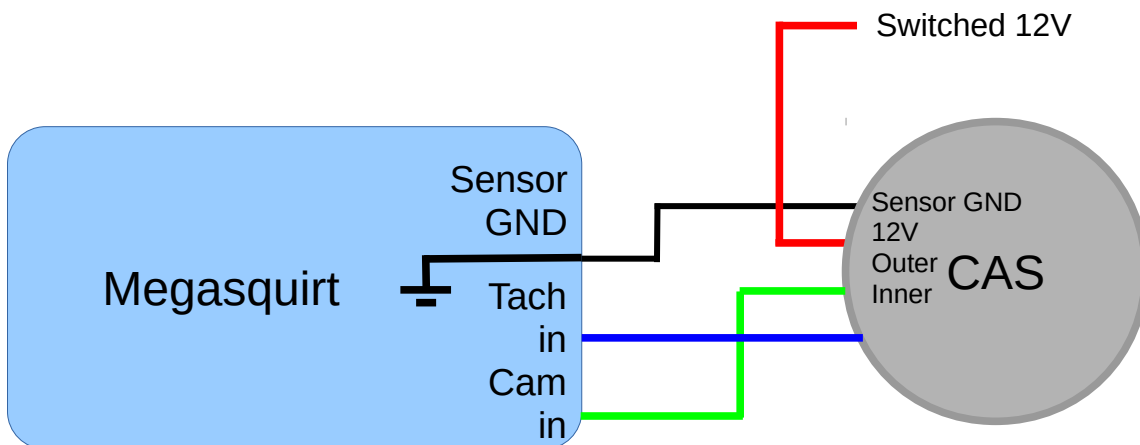

Typical settings:

Spark mode = Toothed Wheel
Trigger Angle/Offset = 0 (not used)
Ignition input capture = ????
Spark Output = Depends on coils / ignitors
Number of coils = Coil on plug
Trigger wheel arrangement = Dual wheel with missing tooth
Trigger wheel teeth = 12
Missing teeth = 1
Tooth #1 angle = 345 (confirm with strobe)
Wheel speed = Crank wheel
Second trigger active on = poll level
Level for phase 1 = ???

6.9.14 Other wheel arrangements

The examples shown here are not an exhaustive list of all the combinations that are possible, for other arrangements of crank and cam wheels you will need to apply the general principles to your install.

6.9.15 Example: Ford Zetec

The Ford Zetec is a popular four-cylinder four-stroke used on many Ford from the mid nineties onwards. As standard these engines use a 36-1 crank wheel and a VR sensor. Set the mainboard as per section 5.2.2.

A high-current coilpack is used and requires two high current ignition outputs - see section 5.3.1.2.

Megasquirt-2 only needs the crank signal to run wasted-spark and batch fire fuel, this is the recommended configuration.

(Connecting and configuring the cam signal would allow coil-on-plug ignition with suitable coils.)

Alternative #1: Use an external 2 channel ignitor and customise the mainboard for logic spark outputs as per section 5.3.1.3

Alternative #2: use a logic wasted spark coil pack such as the VW item (032 905 106B) shown in section: 5.3.1 instead of the stock coilpack and customise the mainboard for logic spark outputs as per section 5.3.1.3

Typical settings:

Spark mode = Toothed Wheel
Trigger Angle/Offset = 0 (not used)
Ignition input capture = Rising (confirm with tooth logger)
Spark Output = Going High
Number of coils = Wasted Spark
Trigger wheel arrangement = Single wheel with missing tooth
Trigger wheel teeth = 36
Missing teeth = 1
Tooth #1 angle = 90 (tweak with strobe)

Wheel speed = Crank wheel

6.10 Neon/420A

The "Neon/420A" mode supports the following vehicles when equipped with a 2.0 or 2.4 4-cylinder Chrysler engine. Also known as "1st gen Neon".

"NS" body models:

1996-2000 Chrysler Town and Country

1996-2000 Dodge Caravan/Grand Caravan

1996-2000 Plymouth Voyager/Grand Voyager

"JA" body models:

1995-02 Chrysler Cirrus

1995-02 Dodge Stratus

1996-2000 Plymouth Breeze

"JX" body models:

1996-02 Chrysler Sebring Convertible

"PL" body models:

1995-02 Dodge Neon

1995-2001 Plymouth Neon

"PT" body models:

01-02 Chrysler PT Cruiser

"FJ" body models:

1995-02 Chrysler Sebring Coupe

1995-2000 Dodge Avenger

The crank and cam signal pattern looks as follows:

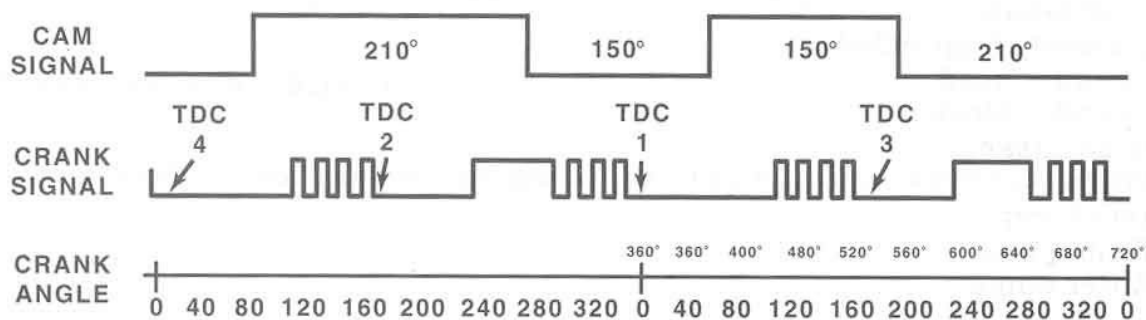

Megasquirt-2 only needs the crank signal to run wasted-spark and batch fire fuel, this is the recommended configuration.

(Connecting and configuring the cam signal would allow coil-on-plug ignition with suitable coils.)

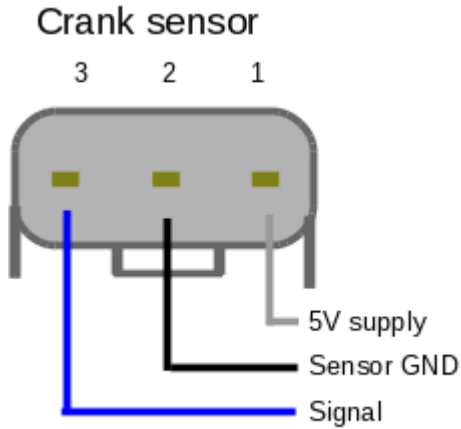

The following diagram shows the recommended wiring using internal high current drivers to drive the standard 420A high-current coilpack. It requires two high current ignition outputs - see section 5.3.1.2

Alternative #1: Use an external 2 channel ignitor and customise the mainboard for logic spark outputs as per section 5.3.1.3

Alternative #2: use a logic wasted spark coil pack such as the VW item (032 905 106B) shown in section: 5.3.1 instead of the stock coilpack and customise the mainboard for logic spark outputs as per section 5.3.1.3

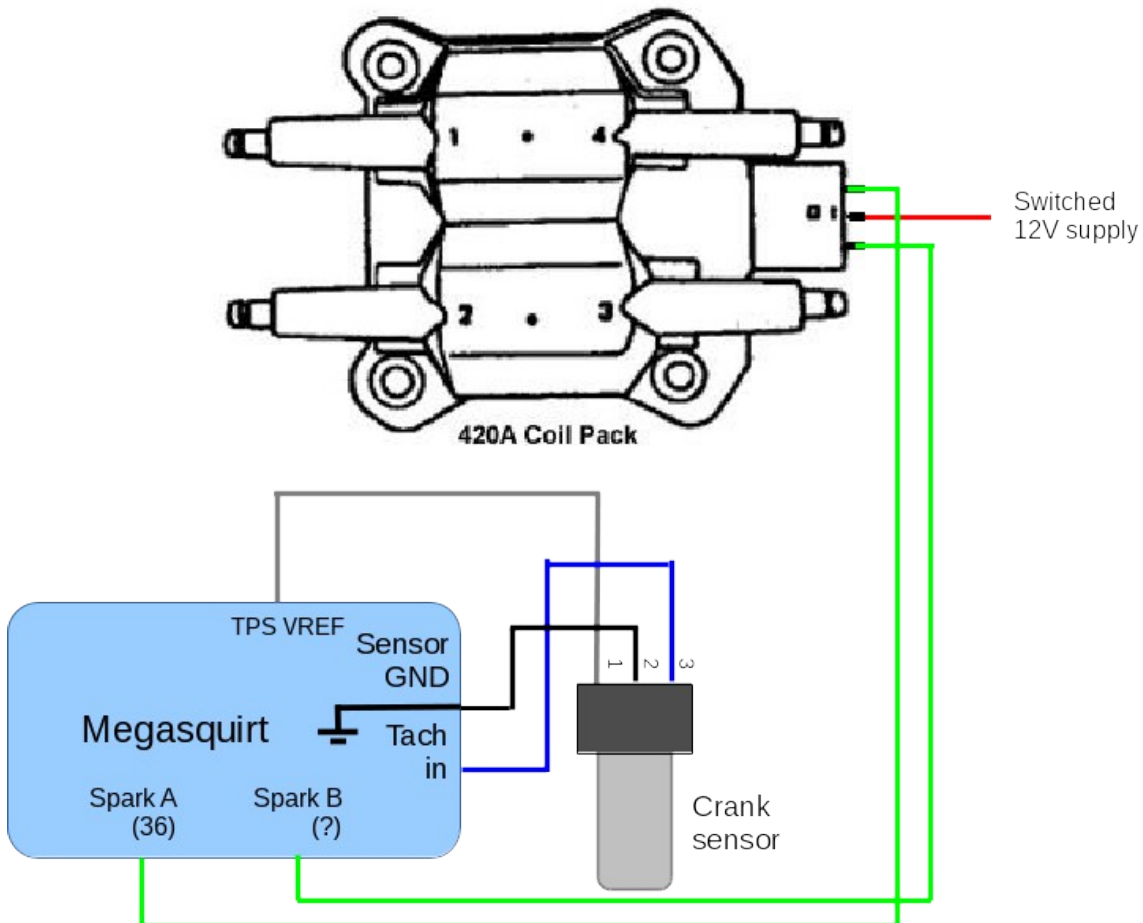

Typical settings:

Spark mode = 420A

Trigger Angle/Offset = 0 (tweak if required)

Ignition input capture = Rising edge

Spark Output = Going High

Number of coils = Wasted Spark

Injectors are wired up using the general diagram in section 4.9.2.1. Connect injectors 1 & 4 to bank 1 and injectors 2 & 3 to bank 2.

6.11 36-2+2 (NGC)

This ignition mode supports Chrysler's "next gen crank" pattern which was an attempt to consolidate the multitude of crank and cam patterns in use across Chrysler engines. It consists of 36 evenly space slots in a crank wheel, with a -1 (or -2) and +1 (or +2) pattern. The cam patterns vary across 4, 6, 8 cylinder variants.

NGC patterns came into use around 2002.

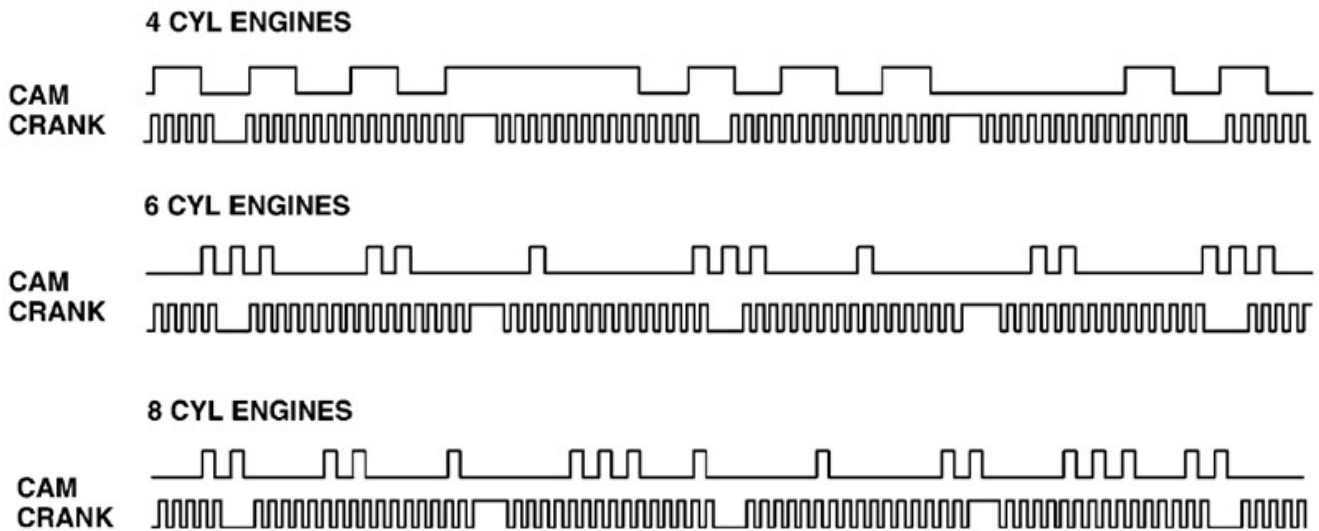

Megasquirt only needs the crank signal to run wasted-spark and batch fire fuel, this is the recommended configuration. Set the mainboard as per section 5.2.3.

Four cylinder example :

The following diagram shows the recommended wiring using internal high current drivers to drive the standard high-current coilpack. It requires two high current ignition outputs - see section 5.3.1.2

Alternative #1: Use an external 2 channel ignitor and customise the mainboard for logic spark outputs as per section 5.3.1.3

Alternative #2: use a logic wasted spark coil pack such as the VW item (032 905 106B) shown in section: 5.3.1 instead of the stock coilpack and customise the mainboard for logic spark outputs as per section 5.3.1.3

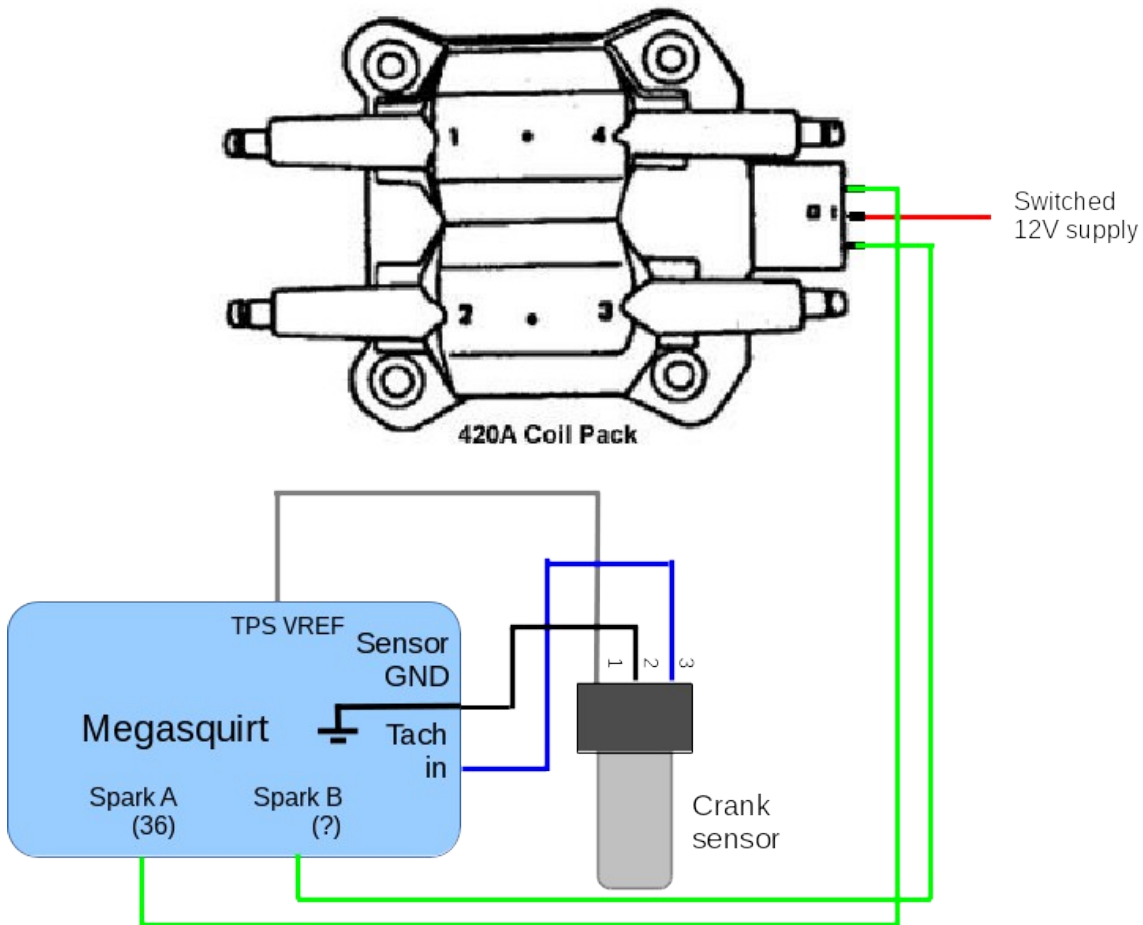

Typical settings:

Spark mode = 36-2+2

Trigger Angle/Offset = 0 (tweak if required)

Ignition input capture = Rising Edge

Spark Output = Going High

Number of coils = Wasted Spark

Injectors are wired up using the general diagram in section 4.9.2.1. Connect injectors 1 & 4 to bank 1 and 2 & 3 to bank 2.

Alternative #1: Use an external 2 channel ignitor and customise the mainboard for logic spark outputs as per section 5.3.1.3

Alternative #2: use a logic wasted spark coil pack such as the VW item (032 905 106B) shown in section: 5.3.1 instead of the stock coilpack and customise the mainboard for logic spark outputs as per section 5.3.1.3

Six and eight cylinder variants are wired up similarly, following the general ignitor and coil wiring diagrams in section 5.3.

6.12 36-2-2-2

The 36-2-2-2 mode is designed for use with 4-cyl Subaru and Mazda RX8 engines with stock trigger wheels and sensor positions.

As standard, these engines use VR type crank sensors.

See the generic instructions in section 5.2 and 5.2.2

Mazda RX8 engines

RX8 engines use rotary specific coils - see section 5.3.4 for wiring.

Typical settings:

Spark mode = 36-2-2-2

Trigger Angle/Offset = 0 (tweak if required)

Ignition input capture = Falling Edge (typically)

Spark Output = Going High

Number of coils = Coil on Plug

Subaru 4cyl engines

Typically, the cam sensor is not used and "wasted spark" or "wasted COP" should be used.

The recommended wiring uses internal high current drivers to drive the standard high-current coilpack. It requires two high current ignition outputs - see section 5.3.1.2

Typical settings:

Spark mode = 36-2-2-2

Trigger Angle/Offset = 0 (tweak if required)

Ignition input capture = Falling Edge (typically)

Spark Output = Going High

Number of coils = Wasted Spark

6.13 Miata 99-05

The 99-05 Miata uses a low resolution crank trigger for primary timing and teeth on camshaft to detect phase. Both crank and cam inputs need to be connected.

See the generic instructions in section 5.2 and 5.2.2

Most engines of this era run coil-on-plug ignition using logic coils.

See the generic instructions in section 5.3 for wiring four logic coils.

Improved timing accuracy can be obtained by upgrading to a regular toothed wheel on the crank shaft, such as the Flyin-Miata 36-2 wheel. (See also section 6.37)

Typical settings:

Spark mode = Miata 99-00

Trigger angle/offset = 0 (adjust with strobe)

Ignition input capture = Rising Edge (Set according to whichever edge gives the most stable signal. If timing advances with RPM, try flipping it.)

Spark output = Going High

Number of coils = Wasted Spark

6.14 Subaru 6/7

This mode is designed for the EJ series engines with the unique "6/7" trigger - there are six unevenly spaced teeth on the crank wheel and seven teeth in total on the cam sprocket for cylinder identification. Both crank and cam inputs need to be connected..

VR sensors are used which can be directly connected, although some experimentation may be required with resistor "shunts" as the signals have been troublesome for some.

See the generic instructions in section 5.2 and 5.2.2

Some/most engines use a wasted spark coil pack. These are believed to be high current and will require high-current driver.

Typical settings:

Spark mode = Subaru 6/7

Trigger angle/offset = 0 (adjust with strobe)

Ignition input capture = Set according to whichever edge gives the most stable signal. (If timing advances with RPM, try flipping it.)

Spark output = Going High

Number of coils = Wasted Spark

6.15 6G72

Known applications include:

- Mitsubishi 3000GT
- Mitsubishi Galant V6
- Some other Mitsubishi and Chrysler V6 models



1991-1992 6G72 use an optical CAS.

Electrically, the two signals on these CAS are connected the same as two hall sensors.

See sections 5.2.3 and 5.2.14.2 for mainboard modifications.

The outer track is considered to be the 'crank' signal and the inner track is the 'cam'.

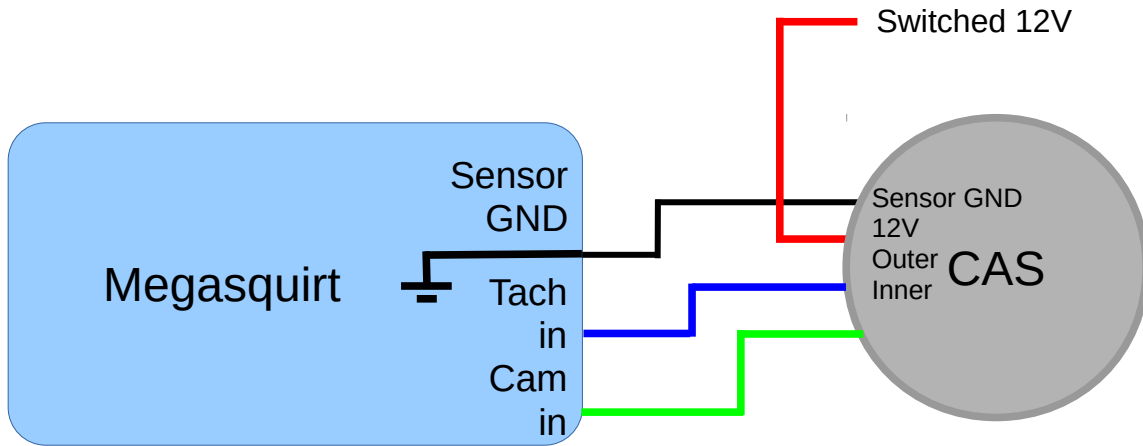

Later 6G72 use two independent sensors on crank and cam, but the signal pattern to the ECU is the same. See sections 5.2.3 and 5.2.14.2 for mainboard modifications.

Connect crank sensor to Tach in
 Connect cam sensor to Cam in

Typical settings:

- Spark mode = 6G72
- Trigger angle/offset = 0 (adjust with strobe)
- Ignition input capture = Rising edge
- Spark output = Going High
- Number of coils = Wasted Spark

6.16 IAW Weber

Known applications include:

- Ford Sierra Cosworth
- Some Fiat and Lancia applications

This application uses a four tooth crank trigger with a VR sensor and a two tooth cam trigger with a Hall effect or VR sensor, depending on the year.

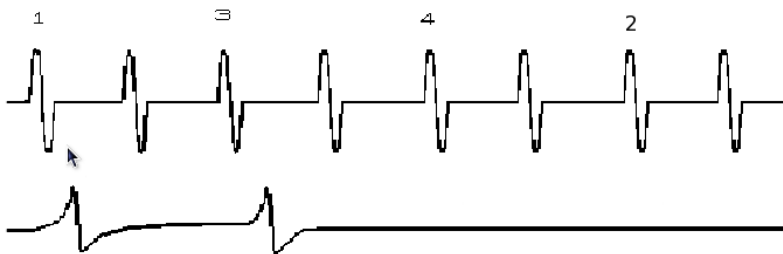

All models, see section 5.2.2 for mainboard modifications for the crank input.
 Models with a VR cam sensor, see section 5.2.14.1 for mainboard modifications.
 Models with a hall effect cam sensor, see section 5.2.14.2 for mainboard modifications.

Typical settings:

Spark mode = IAW Weber

Trigger angle/offset = 0 (adjust with strobe)

Ignition input capture = Falling edge

Spark output = Going High

Number of coils = Depends on application

Some applications use a single high current coil, others use coil-on-plug. External ignitors are likely required.

6.17 Mitsubishi CAS 4/1

Known applications include:

- Mitsubishi 4G91
- Mazda Protege and 323 with optical distributor

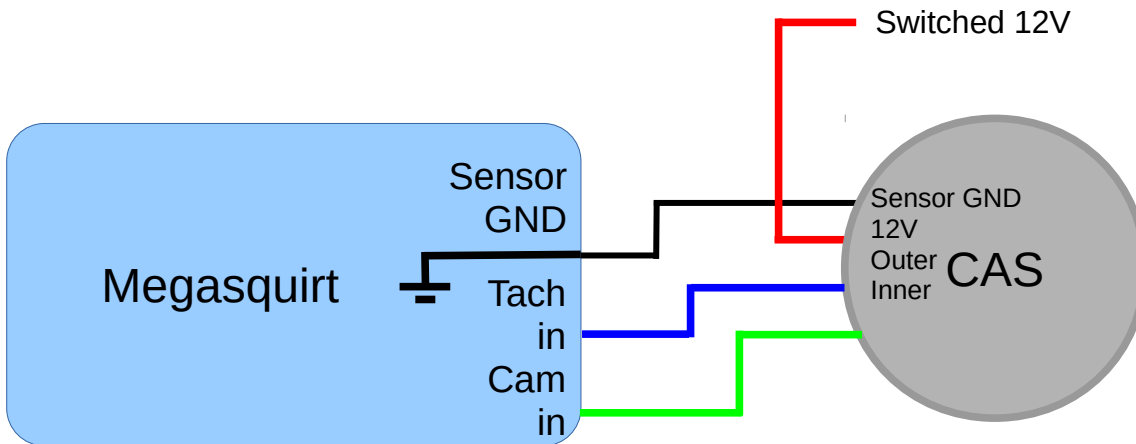

See sections 5.2.3 and 5.2.14.2 for mainboard modifications.

Typical settings:

Spark mode = CAS 4/1

Trigger angle/offset = 0 (adjust with strobe)

Ignition input capture = Falling edge

Spark output = Going High

Number of coils = Depends on application

You will need to set the "Angle between main and return" parameter to the distance between edges of the optical sensor.

Note that if you are not able to get a stable signal off both edges, you should instead use "Toothed Wheel", mode with "Dual wheel" and 4 teeth at cam speed set.

6.18 Mitsubishi 4G63 (and Miata)

Known applications include:

- Mitsubishi 4G63 with distributorless ignition, as used in Eclipse, Galant VR4, and Lancer Evolution

- 1990-1997 Mazda Miata

The 2G 4G63 and pre-1999 Miata (MX5) use a Mitsubishi optical CAS.



4G63 2G CAS

Electrically, the two signals on these CAS are connected the same as a hall sensor and require a pair of pull-up resistors in the wiring harness.

Nissan CA18DET
VG30DETT
Mitsubishi 4G63

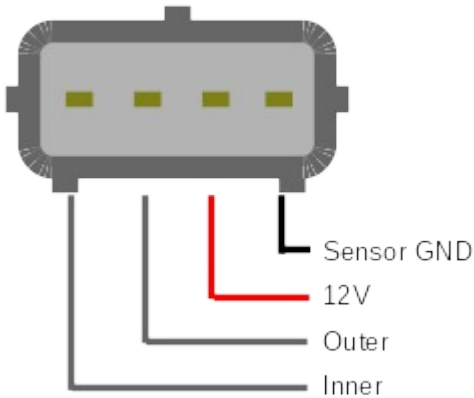

Nissan SR20DET
Mazda Miata/MX5

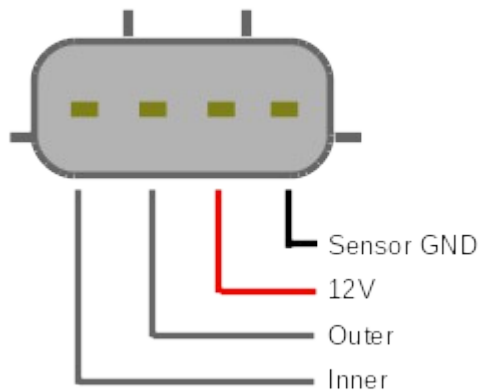

The outer track is considered to be the 'crank' signal and the inner track is the 'cam'.

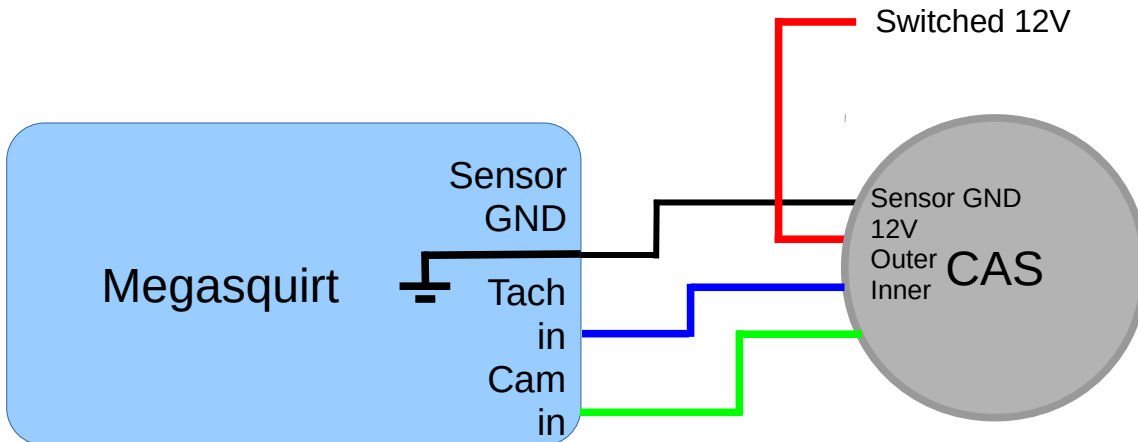

Later 4G63 use two independent hall sensors with a two tooth crank trigger and a two tooth cam trigger, but the

signal pattern to the ECU is the same.

See sections 5.2.3 and 5.2.14.2 for mainboard modifications.

Connect crank sensor to Tach in

Connect cam sensor to Cam in

Typical settings:

Spark mode = 4G63

Trigger angle/offset = 0 (adjust with strobe)

Ignition input capture = Rising edge

Spark output = Going High

Number of coils = Wasted Spark

Most Miata/MX5 of this era use a logic wasted spark coilpack which can be directly connected to the Megasquirt.

6.19 Twin trigger



The twin-trigger mode is designed primarily for 4-cylinder bike engines using a pickup similar to the photo. There is a single tooth and two pickup coils. This allows for wasted-spark ignition.

Supported combinations include:

- Crank wheel. 4 cylinder, 4 stroke engines with wasted spark ignition, non sequential fuel.
- Crank wheel. 2 cylinder, 4 stroke engines with in wasted spark ignition, non sequential fuel.
- Cam wheel. 2 cylinder, 4 stroke engines with in coil-on-plug ignition, non sequential fuel.

This mode can be used on both even fire and odd fire engines.

If possible this setup should be replaced with a regular toothed wheel (e.g. 12-1) for more accurate timing control.

Set the mainboard as per section 5.2.2 and 5.2.14.1.

Typical settings:

Spark mode = Twin trigger

Trigger angle/offset = typically around 10deg (adjust with strobe)

Ignition input capture = Set according to whichever edge gives the most stable signal. (If timing advances with RPM, try flipping it.)

Spark output = Going high

Number of coils = Wasted Spark or Coil-on-plug

6.20 Chrysler 2.2/2.5

This setup is unique to Chrysler 2.2 and 2.5 engines from the 1980s and early 1990s, equipped with multiport injection. (The TBI versions of this engine used Basic Trigger mode instead.) It uses a four tooth cam trigger with a “window” in the middle of one tooth and two hall sensors.

Only one hall sensor is used by Megasquirt, connect to Tach in. Set the mainboard as per section 5.2.3.

Typical settings:

Spark mode = Chrysler 2.2/2.5

Trigger angle/offset = 0 (adjust with strobe)

Ignition input capture = Set according to whichever edge gives the most stable signal. (If timing advances with RPM, try flipping it.)

Spark output = Going high

Number of coils = Single coil

6.21 Renix 44-2-2 (66-2-2-2)

Known applications include:

- 1987-1990 Jeep Cherokee 4.0
- Many 1980s era Renault products

This trigger mode came in a four cylinder variation which used 44 base teeth with two gaps 180 degrees apart, and a six cylinder version with 66 base teeth and three gaps 120 degrees apart.

Typically Renault installs utilize a crank sensor only and output to a single coil and distributor.

Wasted spark or coil-on-plug require a single tooth on the cam and a cam sensor. The cam pulse needs to occur before the missing tooth region that precedes TDC#1 firing.

Typical settings:

Spark mode = Renix 44-2-2

Trigger angle/offset = 0 (adjust with strobe)

Ignition input capture = Set according to whichever edge gives the most stable signal. (If timing advances with RPM, try flipping it.)

Spark output = Going high

Number of coils = Single coil

6.22 Suzuki Swift

Known applications include:

- Suzuki Swift engines with a distributor with a VR sensor and 12 irregularly spaced teeth.

A high-current ignition driver will be required.

Typical settings:

Spark mode = Suzuki swift

Trigger angle/offset = 0 (adjust with strobe)

Ignition input capture = Set according to whichever edge gives the most stable signal. (If timing advances with RPM, try flipping it.)

Spark output = Going high

Number of coils = Single coil

6.23 Suzuki Vitara 2.0

Known applications include:

- Vitara 2.0

This variant uses an uneven crank wheel with eleven teeth.

6.24 Daihatsu 3cyl

Known applications include:

- Some 3 cylinder Daihatsu

This mode is considered experimental. The Daihatsu three cylinder version has 3 equally spaced teeth in a distributor with a fourth tooth adjacent to one of the teeth (3+1) and a VR sensor.

A high-current ignition driver will be required.

Typical settings:

Spark mode = Daihatsu 3cyl

Trigger angle/offset = 0 (adjust with strobe)

Ignition input capture = Set according to whichever edge gives the most stable signal. (If timing advances with RPM, try flipping it.)

Spark output = Going high

Number of coils = Single coil

6.25 Daihatsu 4cyl

Known applications include:

- Some 4 cylinder Daihatsu

This mode is considered experimental. The Daihatsu four cylinder version has 4 equally spaced teeth in a distributor with a fourth tooth adjacent to one of the teeth (4+1) and a VR sensor.

A high-current ignition driver will be required.

Typical settings:

Spark mode = Daihatsu 4cyl

Trigger angle/offset = 0 (adjust with strobe)

Ignition input capture = Set according to whichever edge gives the most stable signal. (If timing advances with RPM, try flipping it.)

Spark output = Going high

Number of coils = Single coil

6.26 VTR1000

Known applications include:

- Some Honda V-twin motorcycles

It uses a 12-3 crank trigger with a VR sensor and no cam sensor.

Typical settings:

Spark mode = VTR1000

Trigger angle/offset = 0 (adjust with strobe)

Ignition input capture = Set according to whichever edge gives the most stable signal. (If timing advances with RPM, try flipping it.)

Spark output = Going high

Number of coils = Wasted spark

Must also set 2 cylinders and Odd-fire.

6.27 Rover#1

Known applications include:

- Rover K-series engines

The crank trigger wheel has 36 base teeth and two one tooth gaps, 180 degrees apart. This only allows a single coil and batch fire injection. Cam input is not supported.

Typical settings:

Spark mode = Rover#1

Trigger angle/offset = 0 (adjust with strobe)

Ignition input capture = Set according to whichever edge gives the most stable signal. (If timing advances with RPM, try flipping it.)

Spark output = Going high

Number of coils = Single coil

6.28 Rover#2

Known applications include:

- Rover K-series engines

The crank trigger wheel with 36 base teeth and four one tooth gaps. This only allows a single coil or wasted spark ignition and batch fire or semi-sequential injection. Cam input is not supported.

Typical settings:

Spark mode = Rover#2

Trigger angle/offset = 0 (adjust with strobe)

Ignition input capture = Set according to whichever edge gives the most stable signal. (If timing advances with RPM, try flipping it.)

Spark output = Going high

Number of coils = Single coil or Wasted Spark

6.29 Rover#3

Known applications include:

- Rover K-series engines

Similar to Rover #2, but the gaps are two teeth wide and positioned differently. As with Rover #2, supports wasted spark and semi-sequential injection, but does not support cam input.

Typical settings:

Spark mode = Rover#3

Trigger angle/offset = 0 (adjust with strobe)

Ignition input capture = Set according to whichever edge gives the most stable signal. (If timing advances with RPM, try flipping it.)

Spark output = Going high

Number of coils = Single coil or Wasted Spark

6.30 GM7X

Known applications include:

- Some GM four and six cylinder engines with distributorless ignitions.

GM refers to the crank wheel in their internal documentation as a 7X trigger wheel. It has six equally spaced teeth and a seventh tooth for cylinder identification.

Typical settings:

Spark mode = GM7X

Trigger angle/offset = 0 (adjust with strobe)

Ignition input capture = Set according to whichever edge gives the most stable signal. (If timing advances with RPM, try flipping it.)

Spark output = Going high

Number of coils = Wasted Spark

6.31 QR25DE

Known applications include:

- Nissan QR25DE and some other Nissan four cylinders.

Requires crank and cam sensors to be connected.

6.32 Honda RC51

Known applications include:

- Honda RC51, RC46, FSC600 and many CBR variants
- AP1 Honda S2000

This one uses a 12 tooth crank trigger and 3 tooth cam trigger, with VR sensors on both.

RC51 is 2 cyl odd-fire.

FSC600 is 2 cyl even-fire.

RC46 is 4 cyl odd-fire.

6.33 GM LS1 (24X)

Known applications include:

- Chevrolet V8s of LS1 family using a 24X crank pattern. (Typically Gen 3.)

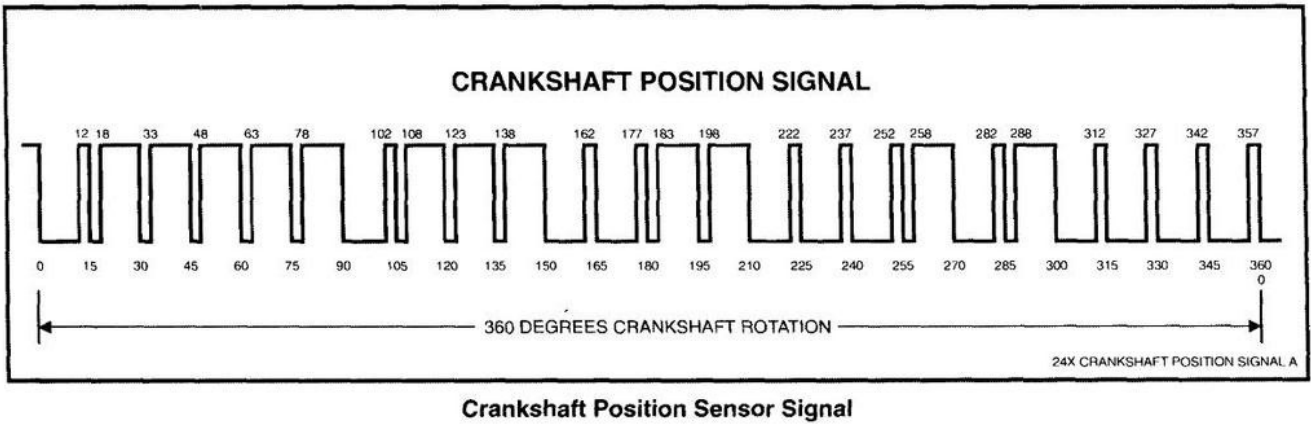

Only the crank sensor is used with Megasquirt-2.

Set the mainboard as per section 5.2.4.

24X (black) crank sensor

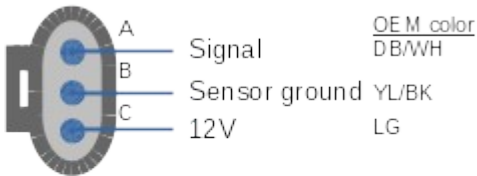

24X (black) cam sensor

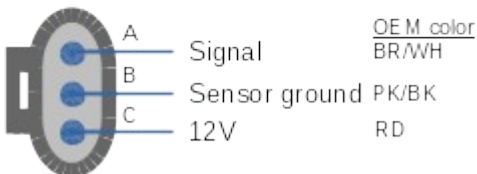

The coils are wired in pairs SpkA = 1&6, SpkB = 8&5, SpkC = 7&4, SpkD = 2&3

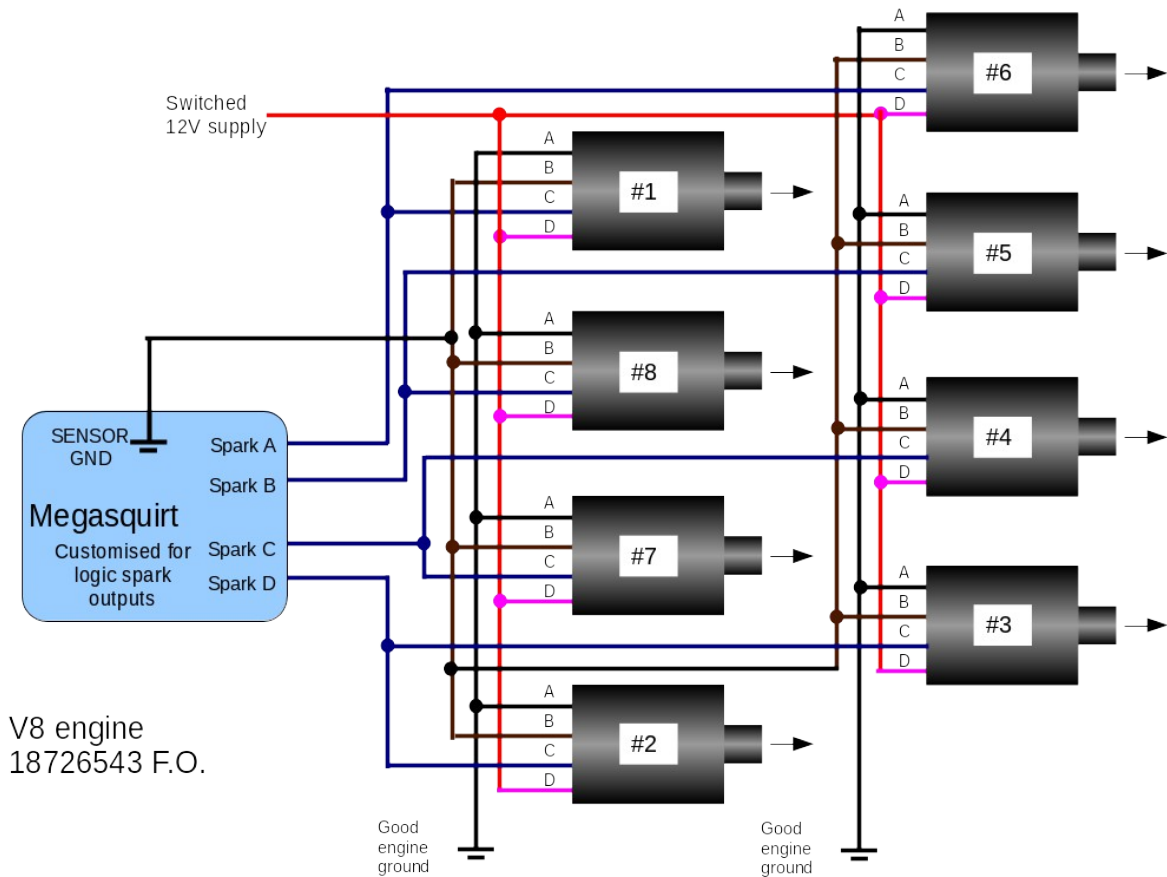

V8 engine
18726543 F.O.

Typical settings:

- Spark mode = LS1
- Trigger angle/offset = 0 (adjust with strobe)
- Ignition input capture = Rising edge
- Spark output = Going high
- Number of coils = Wasted spark

6.34 GM LS2 (58X)

Known applications include:

- Chevrolet V8s of LS2 family using a 58X crank pattern. (Typically Gen 4.)

Only the crank sensor is used with Megasquirt-2.

Set the mainboard as per section 5.2.3.

58X (gray) crank sensor

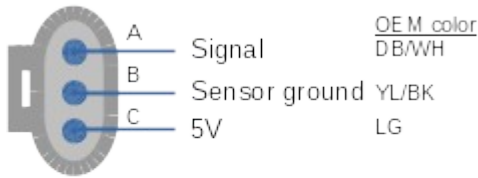

58X (gray) cam sensor

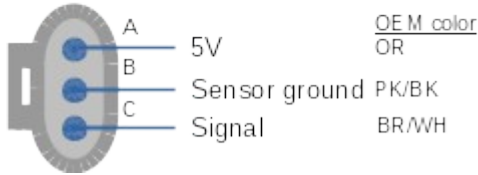

The coils are wired in pairs SpkA = 1&6, SpkB = 8&5, SpkC = 7&4, SpkD = 2&3. Coil wiring is shown in section 6.33

Typical settings:

- Spark mode = Toothed wheel
- Ignition input capture: Rising edge
- Spark output: Going High
- Number of coils = Wasted Spark
- Trigger wheel arrangement = Single wheel
- Trigger wheel teeth = 60
- Missing teeth = 2
- Tooth #1 angle = 15 (adjust with strobe)
- Main wheel speed = Crank wheel

6.35 YZF1000

Known applications include:

- Yamaha YZF1000 / Thunderace
- Yamaha FZR1000
- Yamaha FZR750
- Yamaha FZ700

Typical settings:

- Spark mode = YZF1000
- Trigger angle/offset = 0 (adjust with strobe)
- Ignition input capture = Falling edge
- Spark output = Going high

6.36 HD 32-2

Known applications include:

- Harley Davidson with 32-2 crank trigger

A VR sensor is used on the crank trigger. As standard there is no cam sensor. Phase detection is possible using the MAP sensor.

Typical settings:

Spark mode = HD 32-2

Trigger angle/offset = 0 (adjust with strobe)

Ignition input capture = Set according to whichever edge gives the most stable signal. (If timing advances with RPM, try flipping it.)

Spark output = Going high

Cam sensor = MAP

The front cylinder is considered cyl#1 and therefore connects to SpkA. Sequential fuel is allowed with the two injector outputs.

6.37 Miata 36-2

Known applications include:

- Mazda Miata (MX5) 99-05 fitted with aftermarket 36-2 crank trigger

Typical settings:

Spark mode = Miata 36-2

Trigger angle/offset = 0 (adjust with strobe)

Ignition input capture = Set according to whichever edge gives the most stable signal. (If timing advances with RPM, try flipping it.)

Spark output = Going high

Both crank and cam sensors are VR type and need to be connected.

7 Throttles

The major influence on engine speed on a spark-ignition (gasoline) engine is air-flow. (Contrast a compression-ignition (diesel) engine where there is no throttling and fuel flow governs engine speed.)

For normal running the main throttle plates control the air-flow. At idle an idle valve can be used to provide controlled flow, or a throttle stop screw can be used on the main throttles to allow a low flow during "closed" throttle conditions.

Throttles need to be appropriately sized for the engine displacement and RPM range. Too small and the engine will "run out of steam" at higher RPMs. Too large and tiny throttle movement will allow a large airflow giving jerky low-load operation.

There are a wide range of throttles available. Most factory EFI installs use a single throttle plate. Many aftermarket companies offer USA style 4 barrel carburettor replacement throttle-bodies. Another option that is particularly common on 4-cylinder engines is to fit bike throttle bodies.

Independent throttle body installs free up the most power from the engine, but will need to be balanced (equal airflow for each throttle) and the MAP signal will be weak - consider using "ITB mode" or "Alpha-N."

All throttles will need to be fitted with a TPS if not already included.

Example 4150 style 4-barrel EFI throttle body.



8 Optional Hardware

8.1 (not used)

8.1 Expansion boards

The Megasquirt was designed with enough inputs and outputs to control a simple engine. If additional inputs and outputs are desired, an add-on expansion board may be used.

The Megasquirt has CAN communications that allow the simple 2-wire connection.

Example expansion boards are:

- CANEGT - allows K-type thermocouples for per-cylinder exhaust gas temperature monitoring
- GPIO/ trans - allows control of electronically shifted automatic transmissions
- IO-Expander - DIY assembled product for additional analogue input, relay outputs, GPS, accelerometer, thermocouple.
- Dashes / loggers - many vendors dashboards are compatible with the Megasquirt-2 data stream.

For specific product features and configuration details, please refer to your supplier's documentation.

9 Example wiring

9.1 Nitrous

The following layout shows typical wiring for a wet nitrous system. It is drawn using "PE0" as the ground-switched input and IAC1/2 as the stage 1 and 2 outputs.

With the appropriate software settings other pins may be used for inputs and/or FIDLE+D15 may be used as the outputs.

MS2/Extra nitrous control

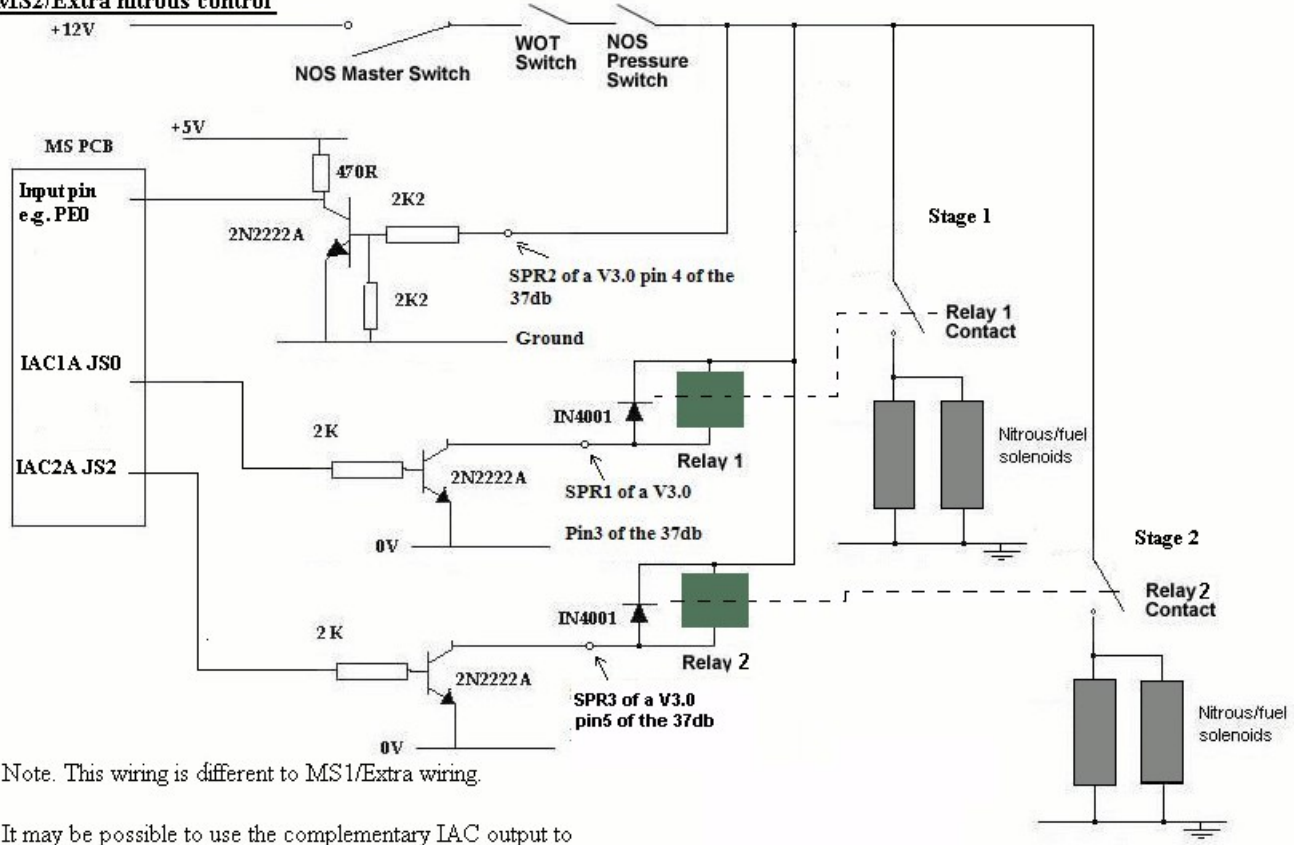

Note. This wiring is different to MS1/Extra wiring.

It may be possible to use the complementary IAC output to directly drive a relay as long as the 750mA limit is not exceeded. DB37 pins are examples only.

9.2 Component pinouts

The following are some typical component pinouts that may be of use while adding additional circuits.

Diagrams / layout of components used in some of the MSnS-Extra hardware mod's

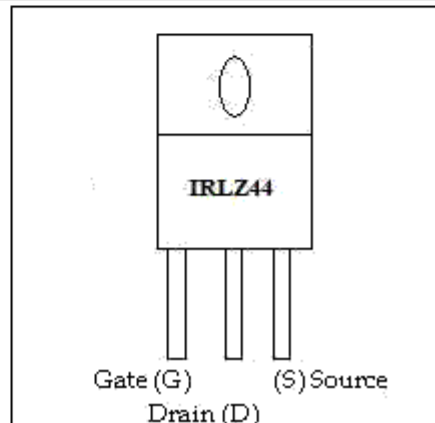
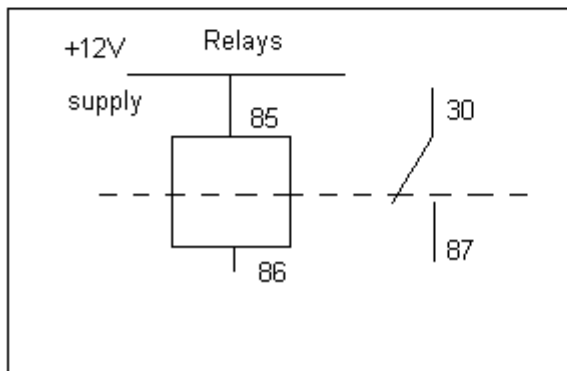
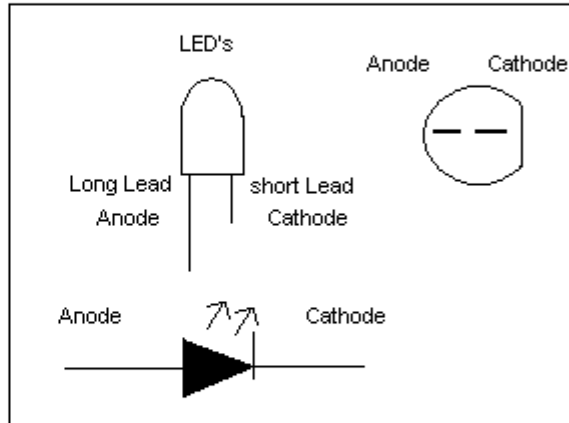
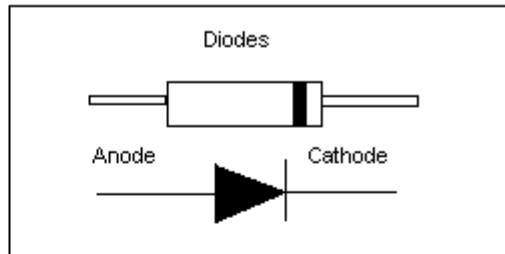
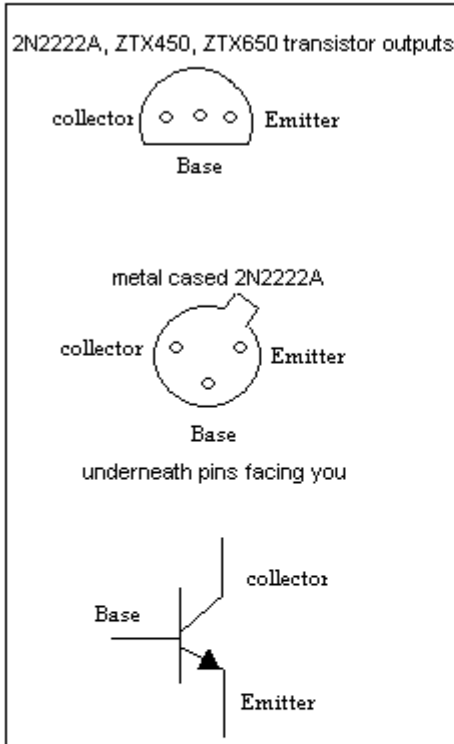

10 Further information

For additional information or to join the community forums for Megasquirt, please visit:

www.msextra.com

11 Appendix A Schematics

The copyrighted Megasquirt schematics are provided for repair, interfacing and education purposes only.

Suggested jumper wires

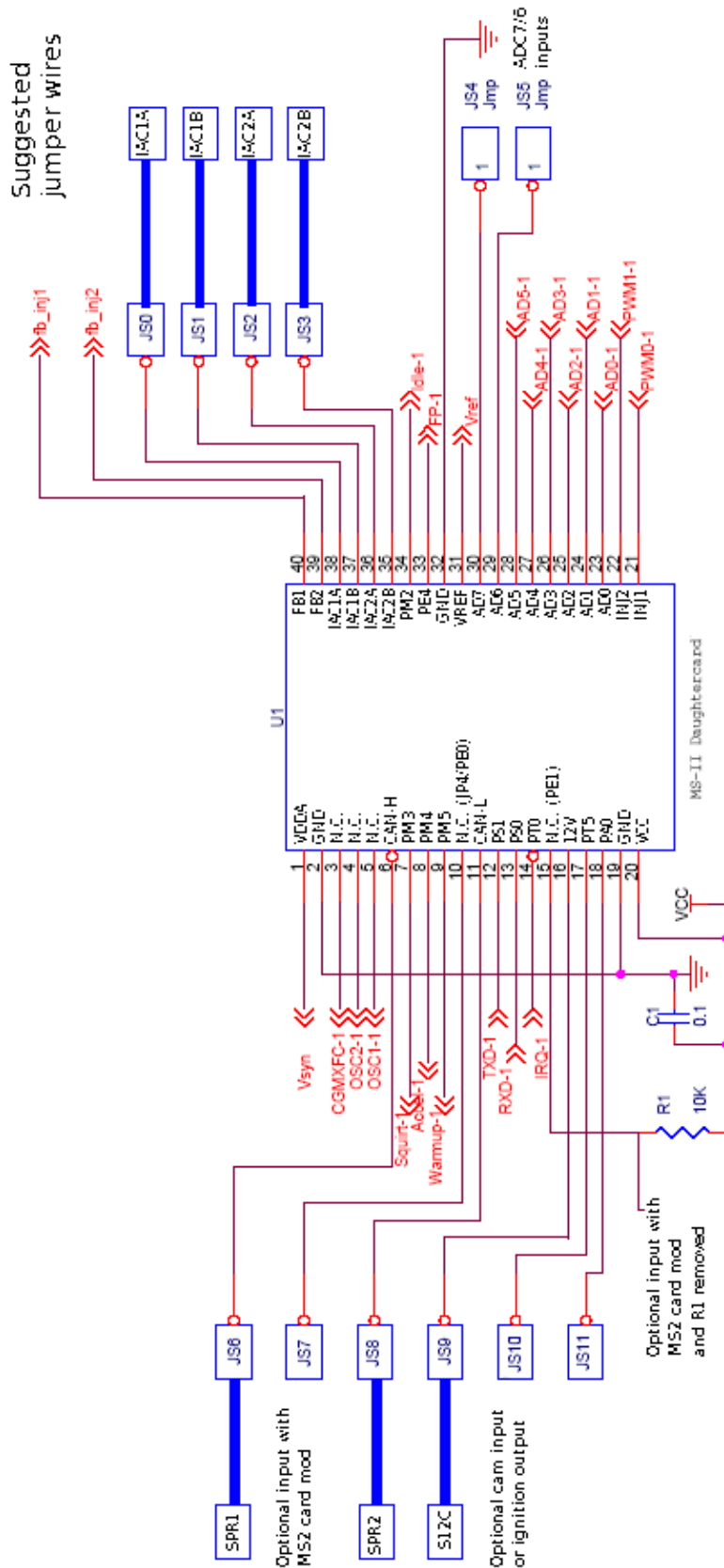

Title		Megasquirt - CPU - B. A. Bowling	
Size	A	Document Number	Rev 2.981
Date:	Sundav, April 17, 2005	Sheet	1 of 8

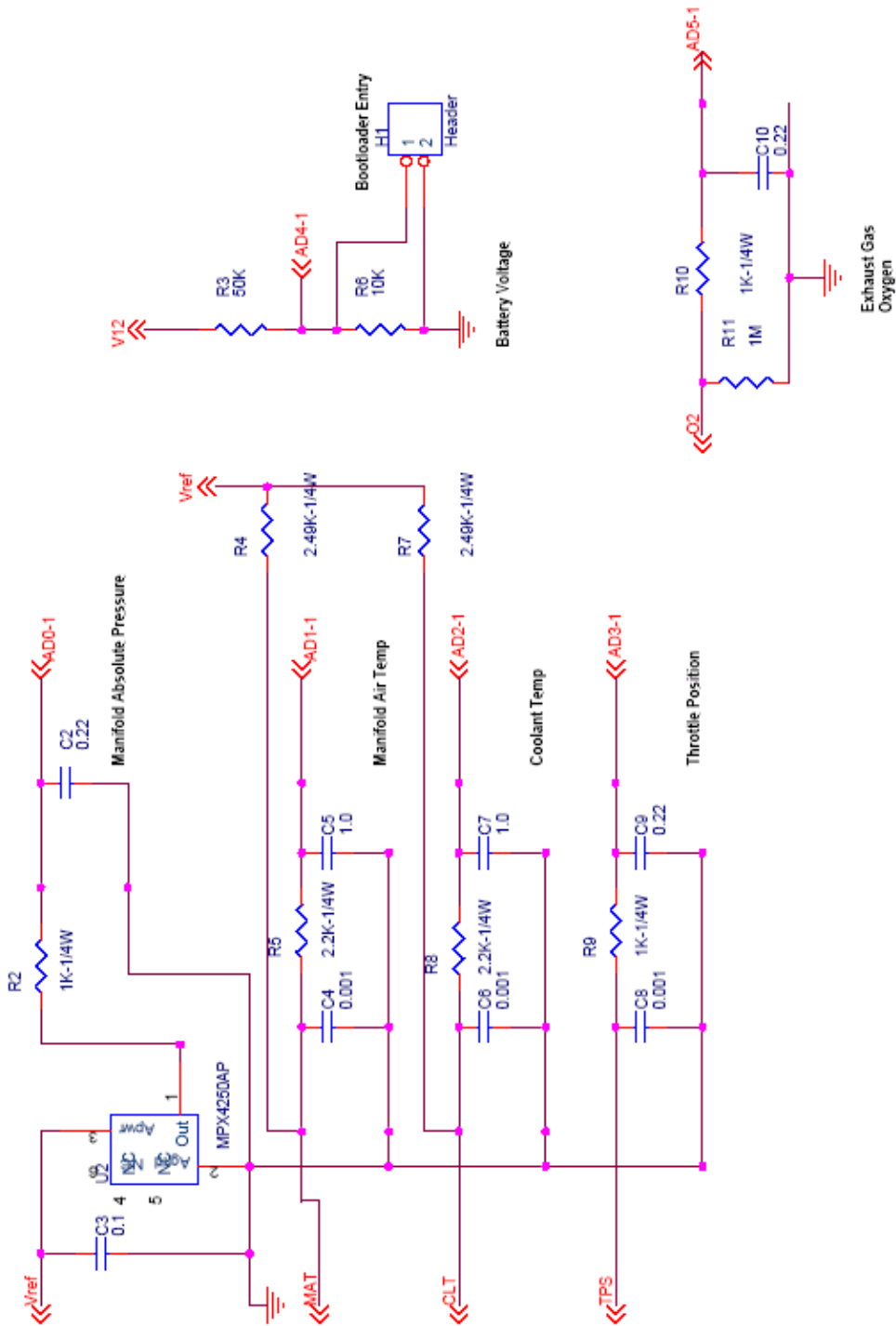

Title		Megasquirt - Input
Size	Document Number	Rev
A	Rev 3.00	3.0
Date:	Sunday, April 17, 2005	Sheet 2 of 8

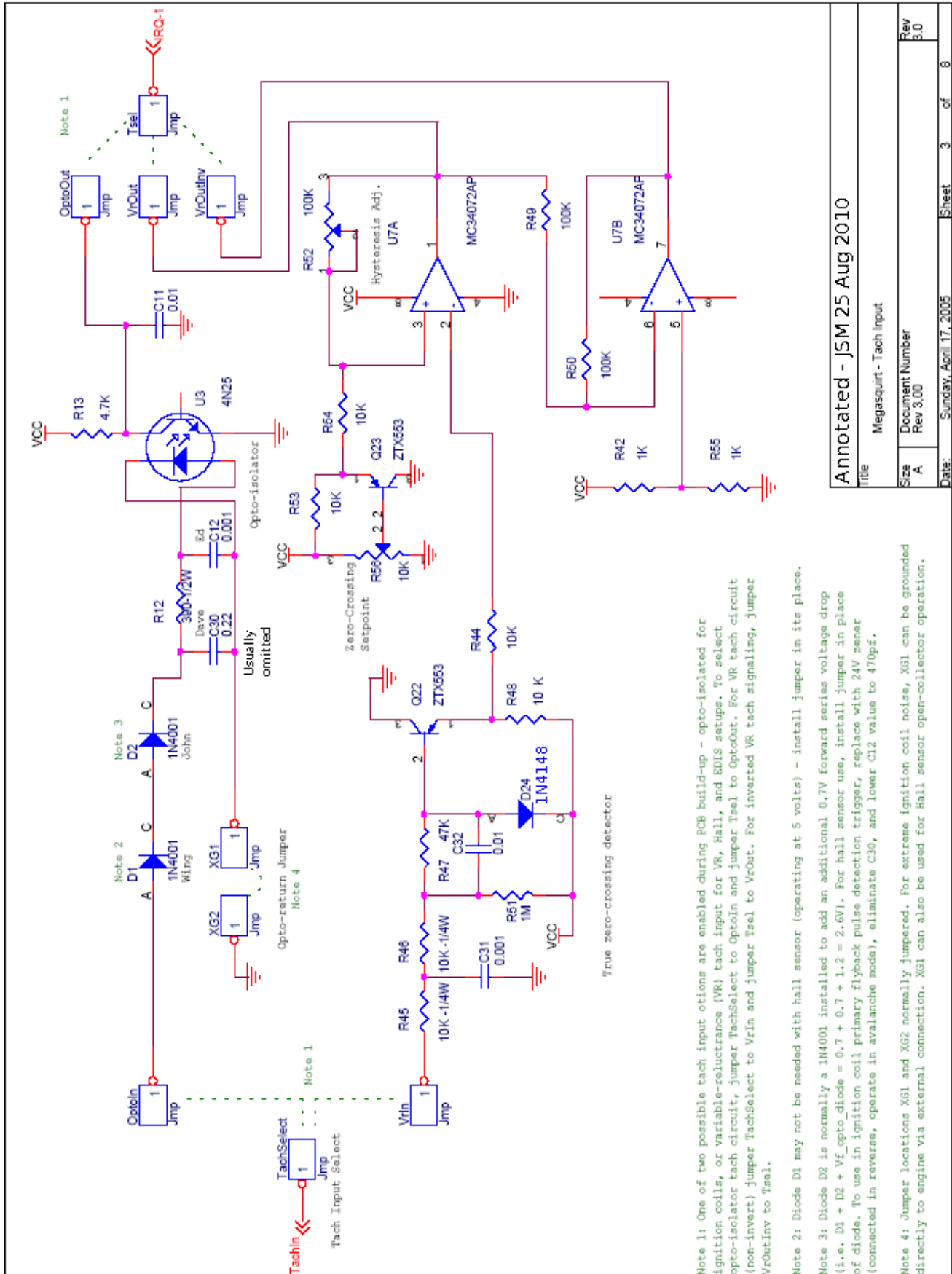

Annotated - JSM 25 Aug 2010

Title		Megasquirt - Tach Input
Size	Document Number	Rev
A	Rev 3.00	3.0
Date:	Sunday, April 17, 2005	Sheet 3 of 8

Note 1: One of two possible tach input options are enabled during PCB build-up - opto-isolated for ignition coils, or variable-reluctance (VR) tach input for VR, Hall, and EDIS setups. To select opto-isolator tach circuit, jumper TachSelect to OptoIn and jumper Tsel to OptoOut. For VR tach circuit (non-invert) jumper TachSelect to VrIn and jumper Tsel to VrOut. For inverted VR tach signaling, jumper VrOutIn to Tsel.

Note 2: Diode D1 may not be needed with hall sensor (operating at 5 volts) - install jumper in its place.

Note 3: Diode D2 is normally a 1N4001 installed to add an additional 0.7V forward series voltage drop (i.e. $D1 + D2 + Vf_opto_diode = 0.7 + 0.7 + 1.2 = 2.6V$). For hall sensor use, install jumper in place of diode. To use in ignition coil primary flyback pulse detection trigger, replace with 24V zener (connected in reverse, operate in avalanche mode), eliminate C30, and lower C12 value to 470pF.

Note 4: Jumper locations XG1 and XG2 normally jumpered. For extreme ignition coil noise, XG1 can be grounded directly to engine via external connection. XG2 can also be used for Hall sensor open-collector operation.

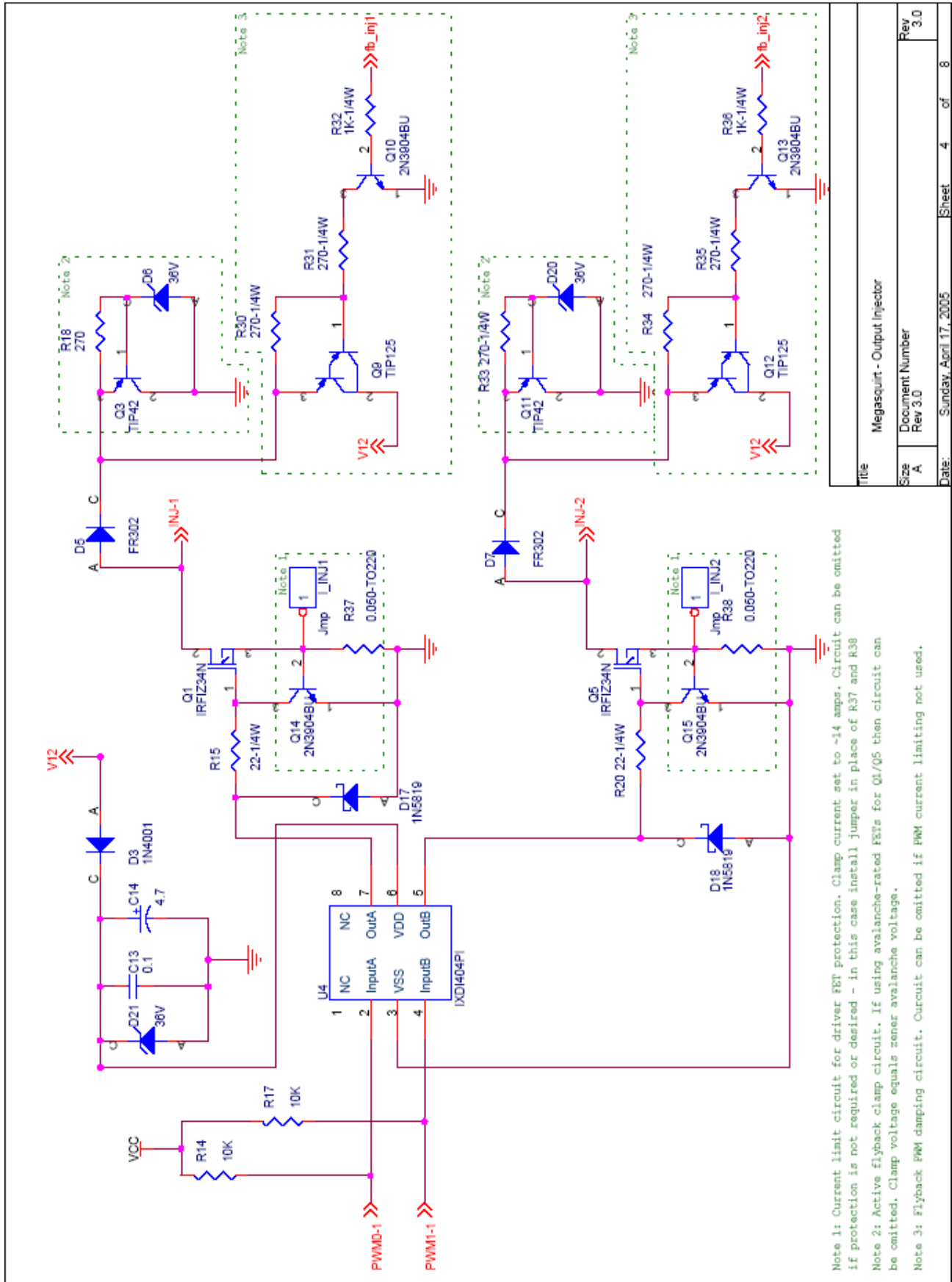

Title		Megasquirt - Output Injector
Size	Document Number	Rev 3.0
A		
Date:	Sunday, April 17, 2005	Sheet 4 of 8

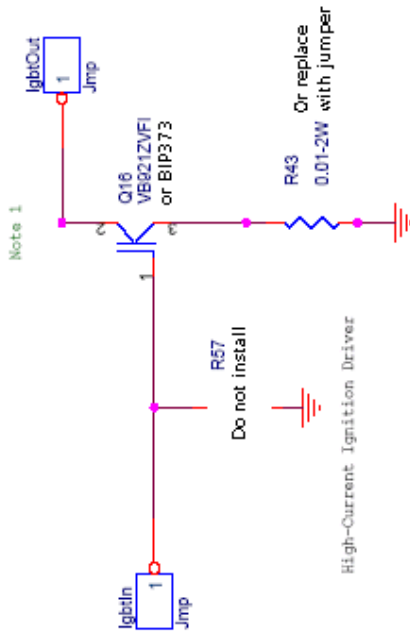

Note 1: High-power ignition drive, optional circuit - populate only if implementing drive.
MS3 installs using MS3X and logic spark outputs will not need this.

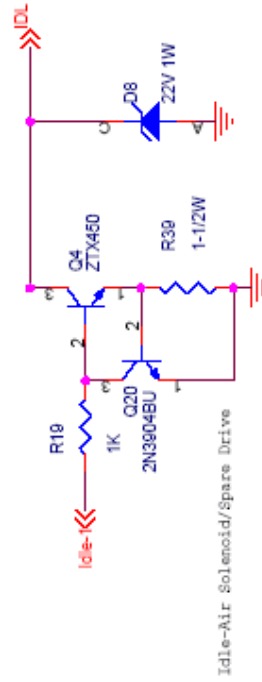
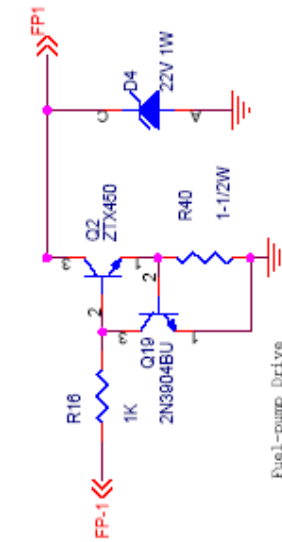

For any install with a normal PWM idle valve, omit D8, Q20, replace with Q4 with a TIP122 and install a 1N4001 to 12V - see M5EXTR-5 manuals.

Annotated - JSM 25 Aug 2010

Title Megasquirt - Output Other

Size A
Document Number Rev 2.2

Rev 3.0

Date: Sunday, April 17, 2005 Sheet 6 of 8

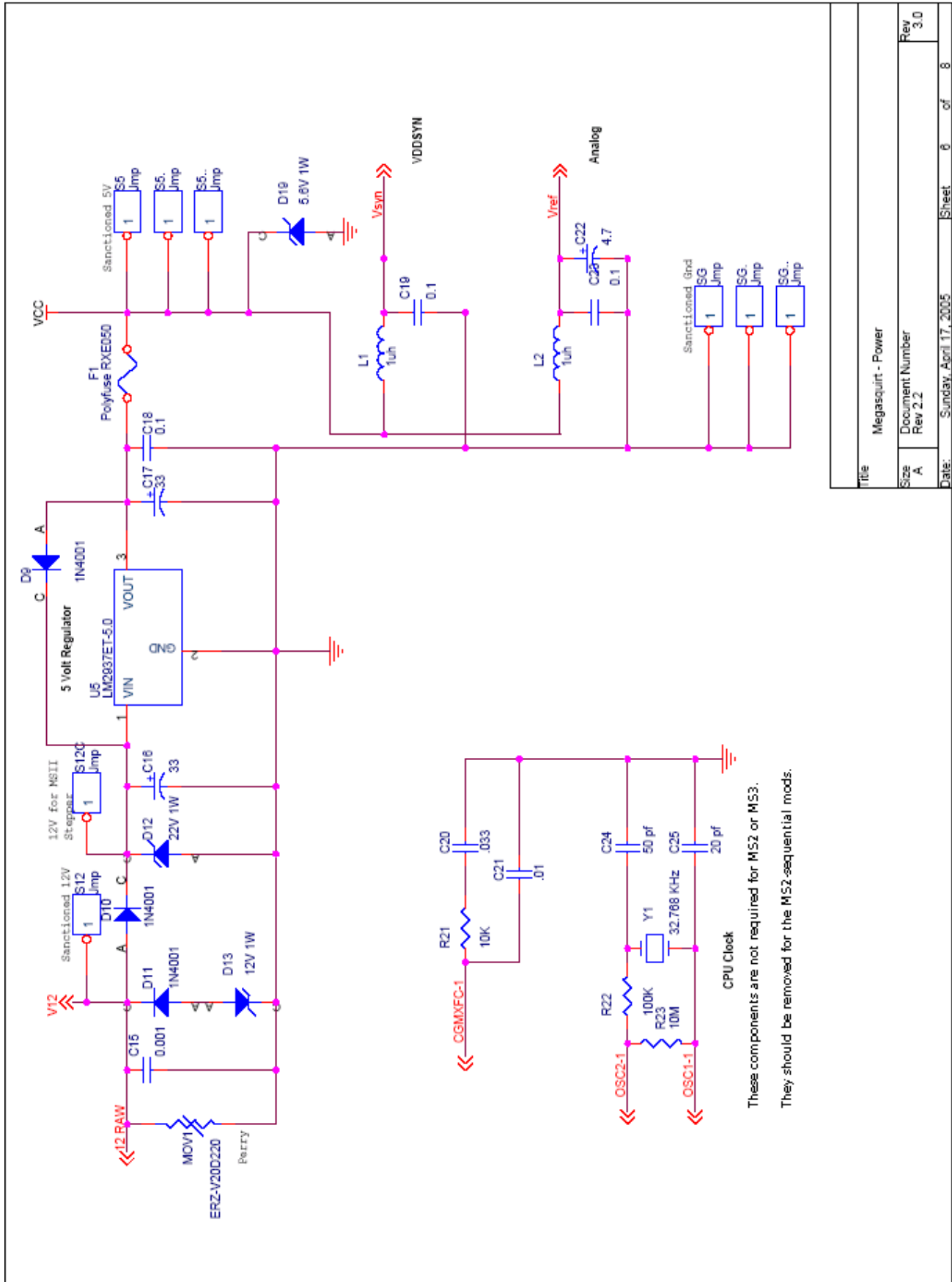

Title		Megasquirt - Power	
Size	A	Document Number	Rev 2.2
Date:	Sunday, April 17, 2005	Sheet	6 of 8
		Rev	3.0

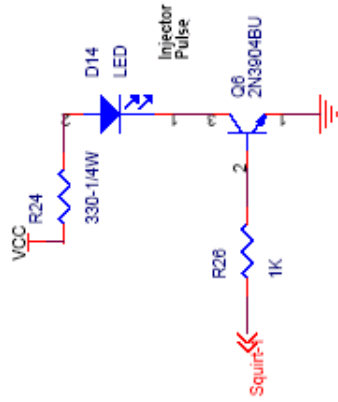
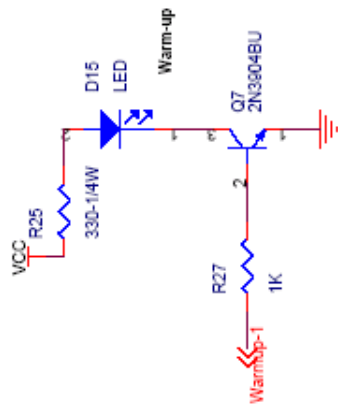

See MSEXTRA manuals for various ways of re-using the LED signal outputs for ignition control

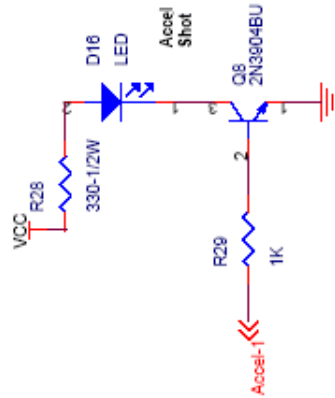

Annotated - JSM 25 Aug 2010

Title MegaSquirr - LED Indicators

Size A
Document Number Rev 2.2

Rev 3.0

Date: Sunday, April 17, 2005 Sheet 7 of 8

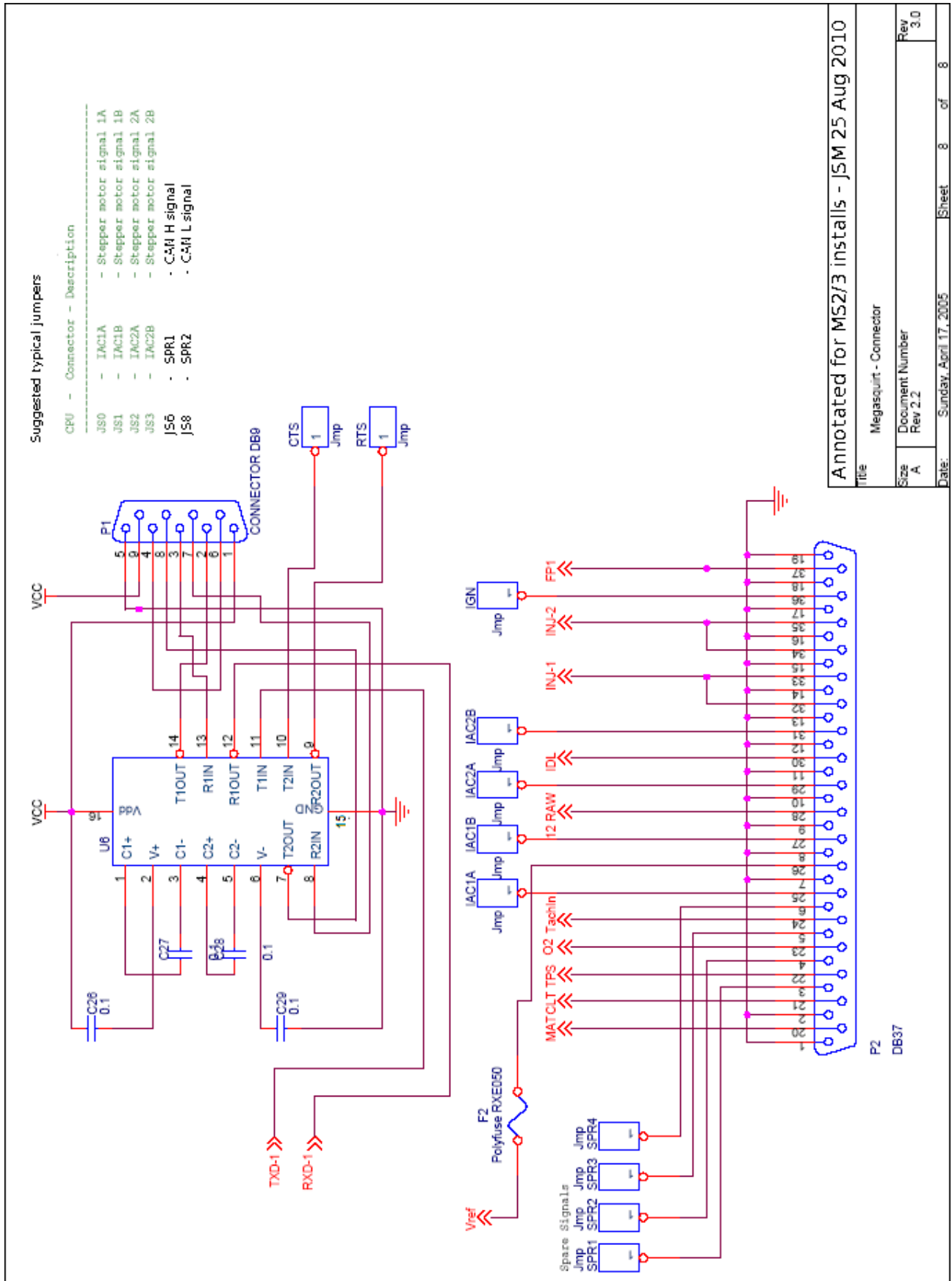

Annotated for MS2/3 installs - JSM 25 Aug 2010	
File	Megasquirt - Connector
Size	Document Number
A	Rev 2.2
Date:	Sunday, April 17, 2005
Sheet	8 of 8
Rev	3.0

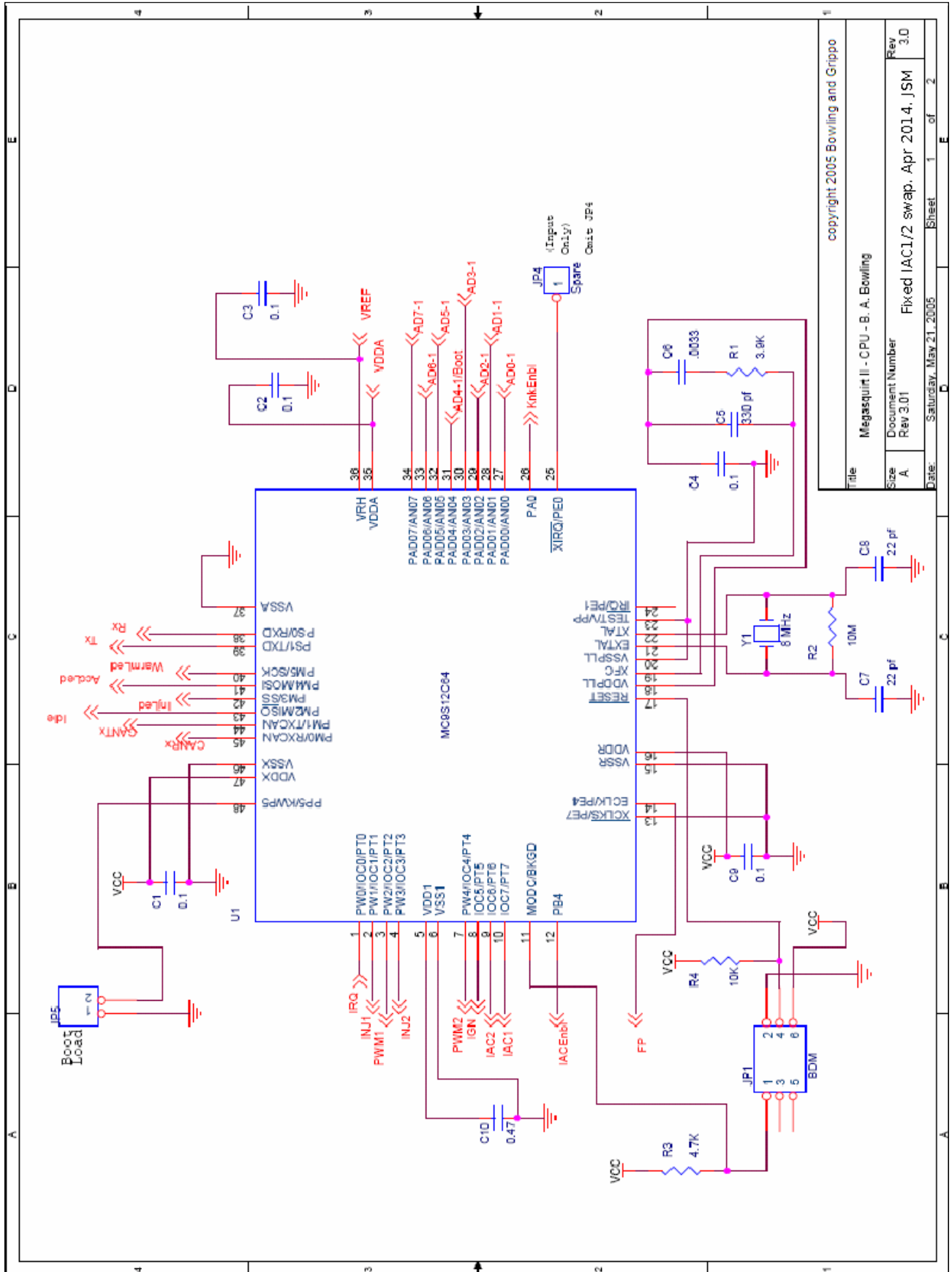

copyright 2005 Bowling and Grippo	
Title	Megasquirt II - CPU - B. A. Bowling
Size	A
Document Number	Fixed IAC1/2 swap. Apr 2014. JSM
Rev	3.0
Date	Saturday, May 21, 2005
Sheet	1 of 2

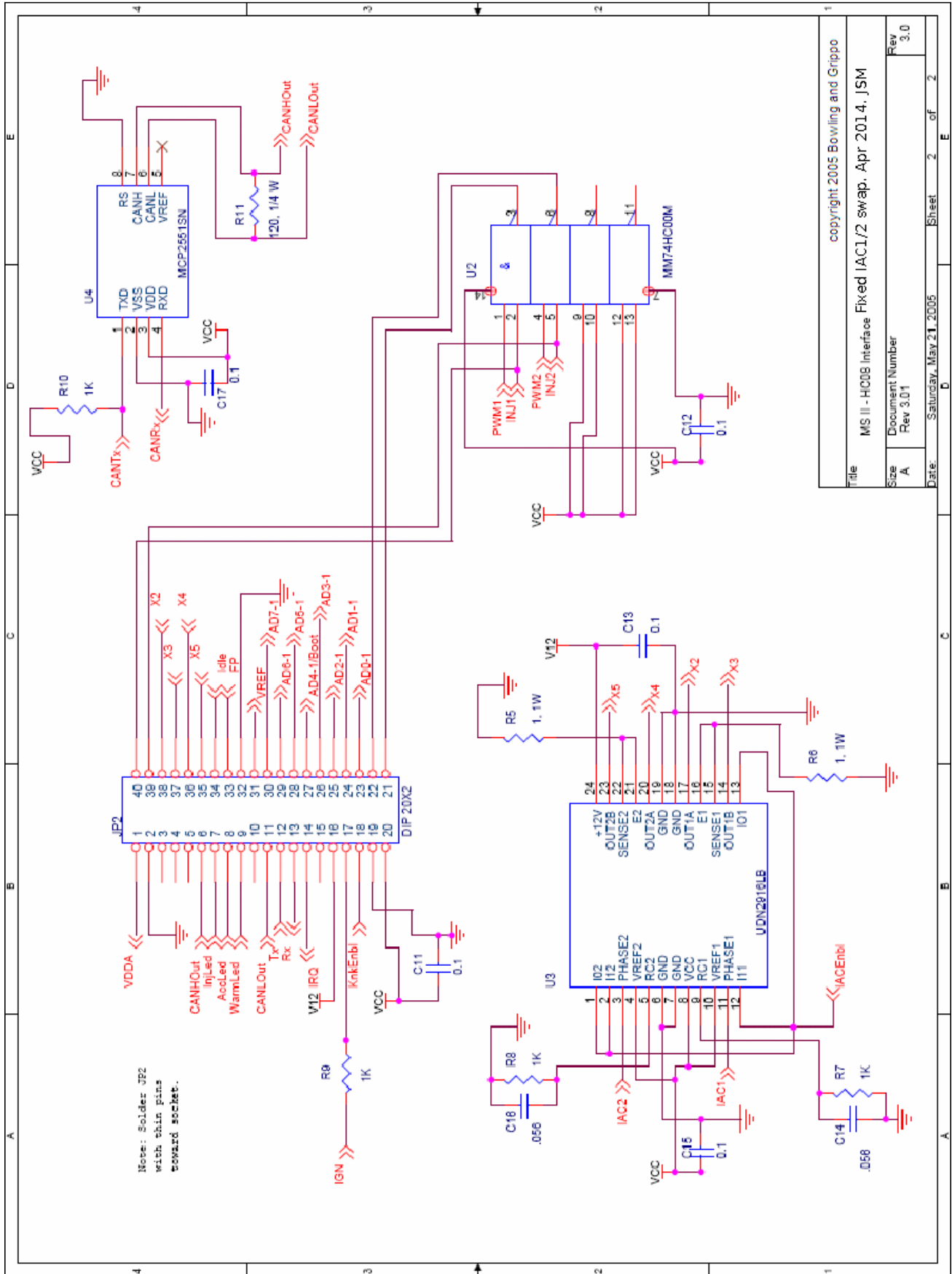

File		copyright 2005 Bowling and Grippo	
Size		MS II - HC08 Interface Fixed IAC1/2 swap, Apr 2014, JSM	
Document Number		Rev 3.01	
Date		Saturday, May 21, 2005	
Sheet		2 of 2	

Relay Board

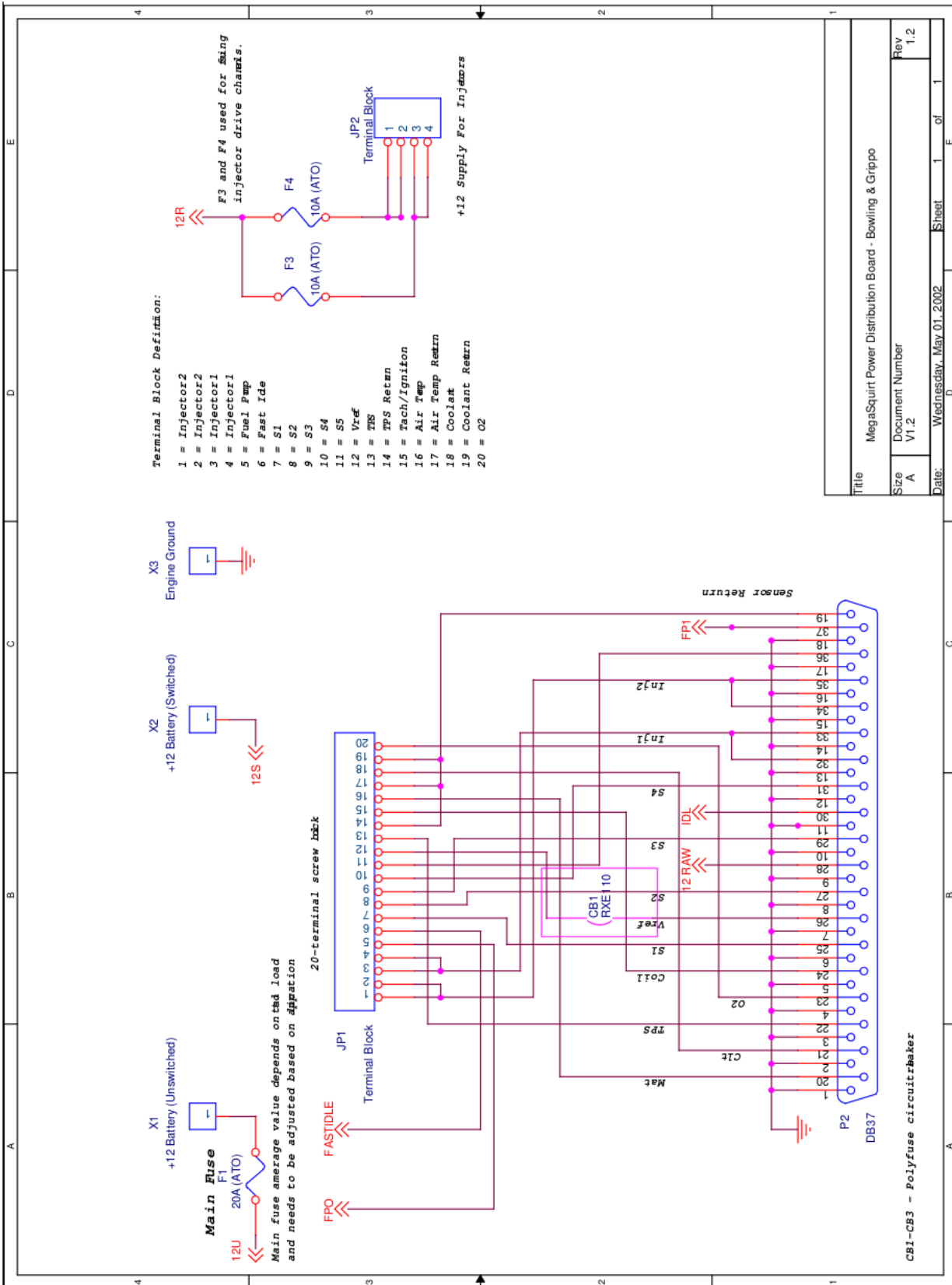

Title		MegaSquirt Power Distribution Board - Bowling & Grippo	
Size	Document Number	Rev	Rev
A	V1.2	1.2	1.2
Date:	Wednesday, May 01, 2002	Sheet	1 of 1

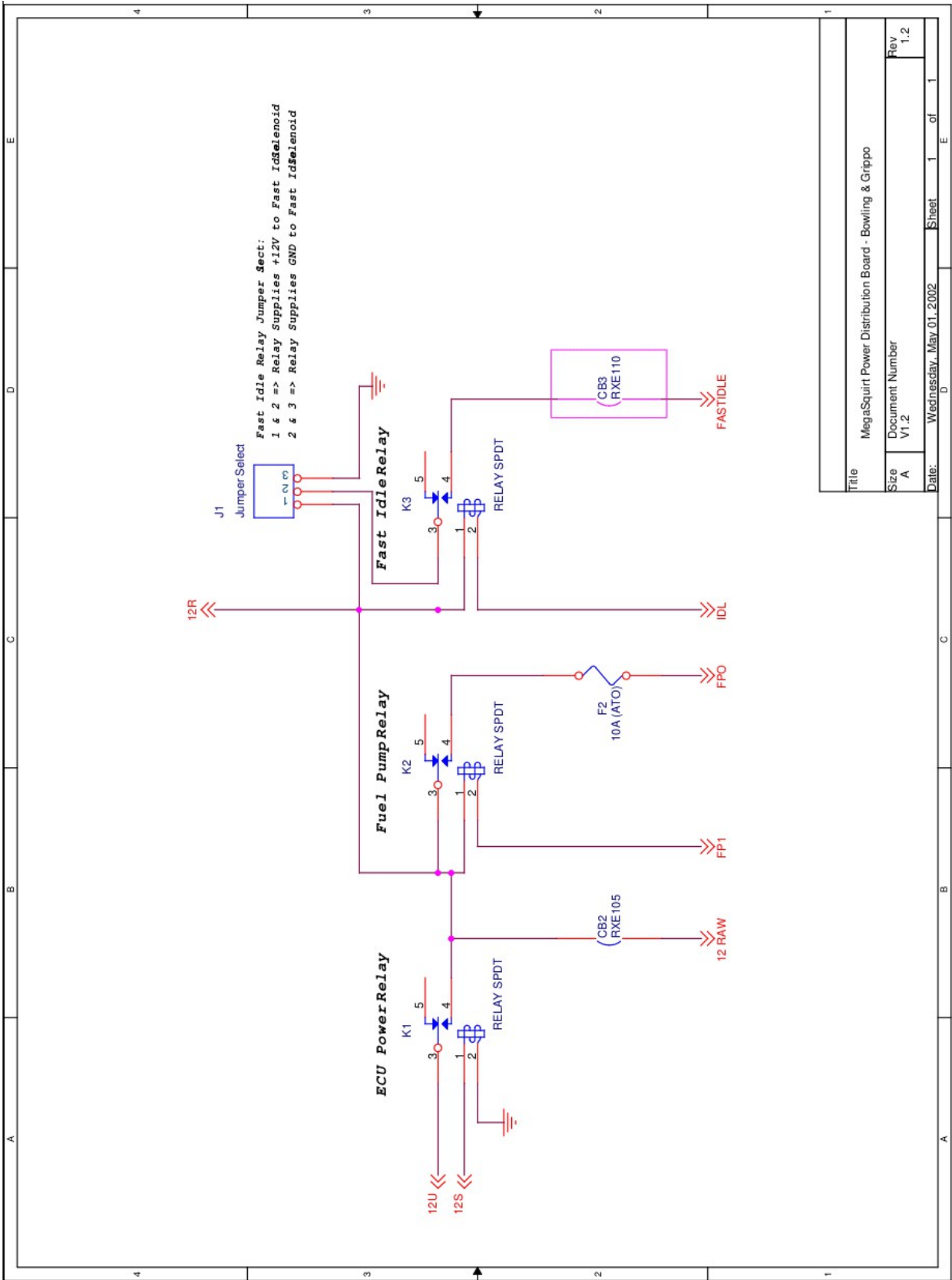

Title		MegaSquirt Power Distribution Board - Bowling & Grippo	
Size	Document Number	Rev	
A	V1.2	1.2	
Date:	Wednesday, May 01, 2002	Sheet	1 of 1

12 Appendix B: junkyard guide to finding EDIS

12.1 North America - EDIS4

Early to mid 1990s Ford Escort/ Mercury Tracer with base 1.9L SOHC engine were fitted with the EDIS4 system. You can tell the engine because it has a tubular aluminium (NOT cast) inlet manifold.

The EDIS4 module is mounted just behind the fuse box on the drivers side of the engine bay, it has a label on the plug that says EDIS4. The bolts are 10mm AF. You are advised to remove the fuse box first for easier access. Cut off as much as the harness as you can.

Looking toward the passenger side end of the engine, the VR sensor is above and to the left of the end of the crankshaft. The easiest way to access the sensor is to remove the front wheel (if it's not already removed), lie on your back, and reach up from the bottom to access the sensor mounting bolts. The bolts are either small metric or star bit. Once it's off, the cable is most easily cut from the top.

The crank pulley bolt is 19mm. You will need to stop engine from turning, various methods have been suggested. 1) remove the head, put some rocks into the bore and refit the head. 2) remove a spark plug and put a long bar down the hole 3) remove a plug from cylinder with piston at BTDC and coil in some rope, remove rope when finished.

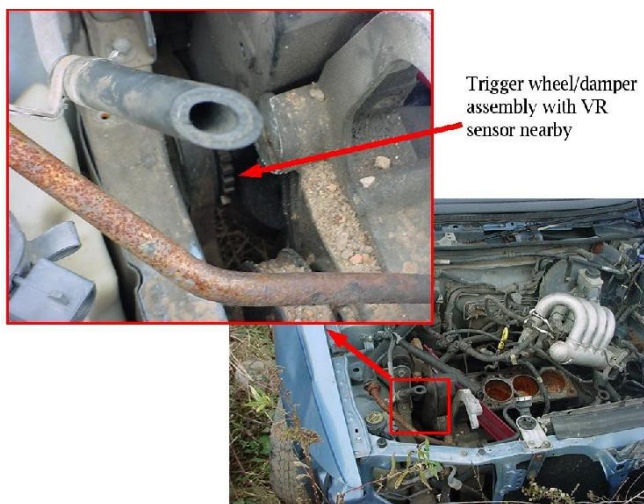
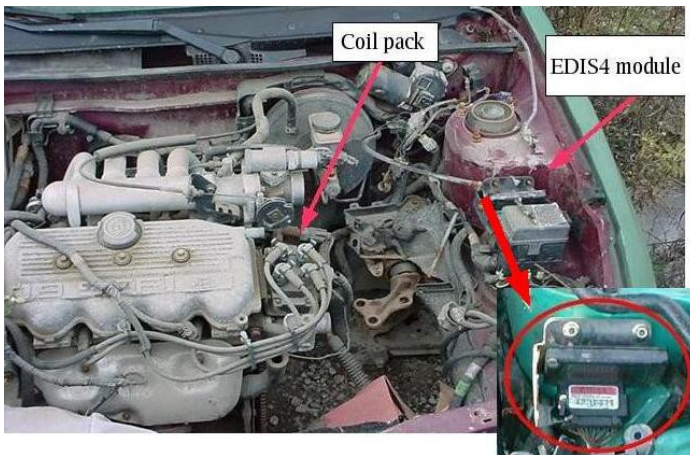

12.2 Europe - EDIS4

1989-1993 Fiesta XR2i 1.6

1990-1992 Fiesta RS turbo

1989-1994 Escort 1.6i

1990-1994 Orion 1.6i

Modules are all in the engine bay and typically located in the middle of the bulkhead or the right hand side as you face the car.

Known part numbers are: 89FB-12K072-AC, 91AB-12K072-AA



Orion CVH MPI

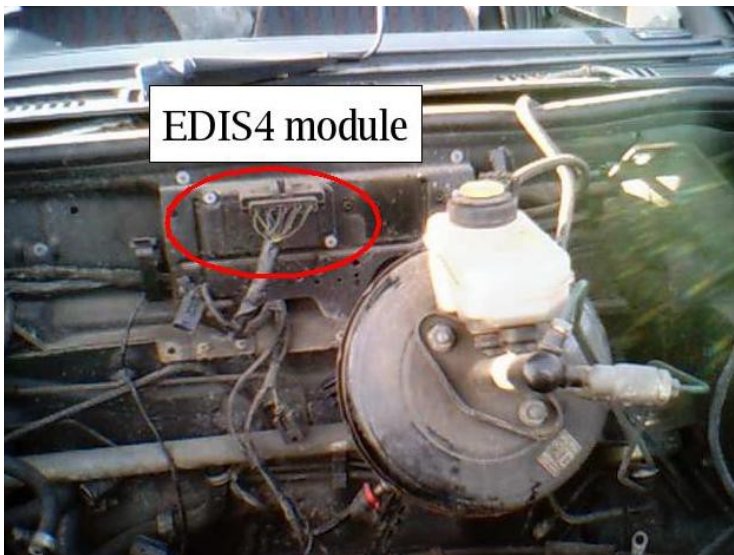

Fiesta / crossflow Escort

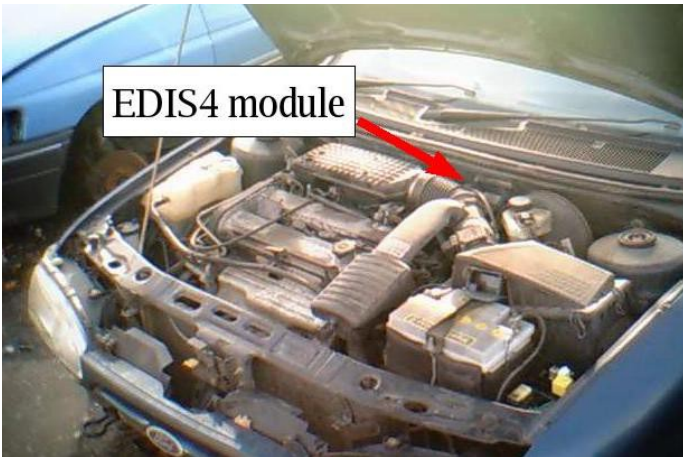

Mondeo with 1800/2000 engine.

Location of the VR sensor varies. On the small CVH engines it pokes through the rear flange of the engine towards the flywheel. 1.8CVH Sierra has one on the front. 2.0DOHC Sierra/ Granada is in the block at the left side way below the inlet manifold. Duratec V6 (Mondeo) is mounted near the front, it also has a cam sensor that works too.

The mounting bolts are either small metric or star bit.



Escort / Fiesta location on engine flange above starter.

Do not confuse with the ESC II hybrid module which has a vacuum tube and comes on the carb model cars.

There is also an aluminium one to avoid as well.



12.3 Europe - EDIS6

up to 1995ish Mondeo V6 automatic

Ford/Cosworth Granada Scorpio 24v V6

Module located rear left of engine bay as you face the car.

Known part numbers are: 90GB-12K072-AB

12.4 Europe - EDIS8

Chances of finding one of these in a scrapyard are very low! Not known to have been installed on any European built vehicles. Your best bet is either to import a module from the USA or buy new. I would suggest buying the other bits locally.

For connectors try one off another car if all the wires are in use or one off an ESC module. The number of wires used in the connector varies so check they are all there!

There is a possibility of using 2 EDIS4 modules to drive a V8. But now that the MS ECU can directly drive 4 coils (V8 in wasted spark) this is no longer necessary.

12.5 Europe - 36-1 trigger disc

The 1.8CVH Sierra has a useful disc pressed onto the back of the crank pulley

All of the other CVH installs have the trigger teeth cut into the flywheel and so are useless.

For a scrap yard trigger disc, remove from 1.8CVH Sierra. You will need to stop engine from turning, various methods have been suggested.

- 1) remove the head, put some old bolts or other junk into the bore and refit the head.
- 2) remove a spark plug and put a long bar down the hole
- 3) remove a plug from cylinder with piston at BTDC and coil in some rope, remove rope when finished
- 4) Jam something into the flywheel teeth



If you are after a pressed steel disc, try part no. 1078767 from Ford, this came on the 16v DOHC Granada engines. Alternatively many retailers sell universal 36-1 trigger wheels.

12.6 Europe - VR sensor



Usually it is easiest to get from the same vehicle as the EDIS module so the wiring harness wiring colors match. Or any vehicle with a trigger disc will yield one, so CVH Fiesta/Escort/Orion or Fiesta with Valencia (crossflow) engine with ESCII hybrid, DOHC Sierra/Granada, Mondeo.

12.7 World - Coilpack(s)

Fords from the EDIS era and beyond use suitable coilpacks.



13 Appendix C: V3.0 Board Assembly

13.1 Introduction

This manual page is primarily intended to help you through the DIY soldering together of the V3.0 mainboard. If you bought a pre-assembled Megasquirt, then this should all be covered. This may also be of use if you are changing the installation of a Megasquirt and need to alter the tach input.

Before starting, be sure to have the following tools:

- Soldering iron with small tip suitable for electronics
- Solder
- Wire cutters / snips
- Screwdrivers

Here's a typical Megasquirt kit (DIYautotune kit shown.) All of the components are supplied in individual bags per component type with labels indicating the bag contents and their identification on the board.



The assembly method presented here is intended to be an efficient method to getting the board built. (Other guides do exist that step the builder through sub-sections with individual testing.)

13.2 Build choices

During assembly, there are some choices that will influence the build.

You might need to add spark drivers. See section 5.3.0

PWM idle - If you are running PWM idle then you will need to add an additional drive transistor. See section 3.5.4.2

Cam input - if you need a cam input you may need to add a circuit for one. See section 5.2.14

13.3 Assembly

1) It is assumed you can already solder, if not then there are lots of good articles that explain how to do that on the internet already, so we won't cover that here.

If you are inexperienced at soldering then assembling the Megasquirt simulator (stim) or another electronics kit first is strongly advised. Some components on the board are quite fiddly and one small solder-bridge is enough to cause big problems.

For self assembly it is expected that you will have bought a kit from one of the recommended suppliers. The description below assumes all of the same valued components are in bags (e.g. R39 and R40 are the same value, so would be in one bag, C16 and C17 are the same values, so would be in another bag, etc) as they would be from a MegaSquirt kit supplier.

(While it is possible to buy all the parts individually, for a single MegaSquirt build this is likely to be extremely time consuming and not worth the effort - just buy a complete kit, really.)

2) Clear space on a work bench with good lighting. Get your tools together - soldering iron, solder, stand, wire snippers etc.

3) Start the build by soldering in the 2 connectors (37 pinned and 9 pinned items)

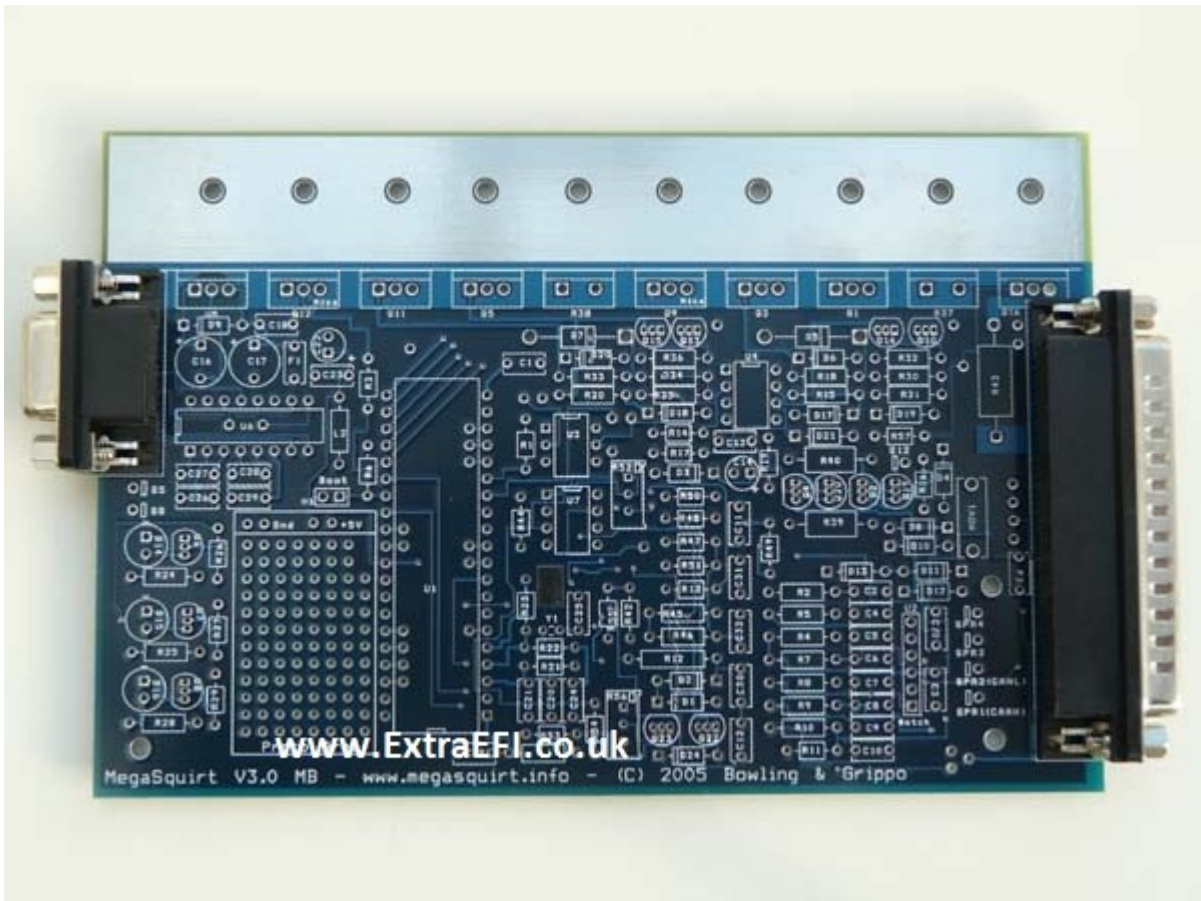

4) Next get all the bags of resistors together, keeping them in the bags. (R1, etc)

Find R12, R37, R38, R43, R39 and R57. Put them out of the way for the moment as you don't need them yet. R57 is never needed and should not actually be part of the kit.

5) Now solder all of the rest of the ordinary resistors in place - soldering from the top. Note: There is no polarity for resistors, so they can fit in either way round.

6) Now solder in the two variable resistors R52 and R56 ensure the adjusting screw matches the legend on the silkscreen. Even though these look identical, they are different values so do not mix them up. Solder from below.



7) Next get all the bags of diodes together, keeping them in the bags. (D1, etc) Note, ALL of the diodes have a strip on them that MUST go the same side as the strip marked on the board!

8) Find D1 and D2 and put them to one side. Keep both these diodes as you may need them (Fidle output mods). Note, D1 may need installing if your using a coil -ve triggering setup.

9) Find D8 and keep this to one side as you may need it later. (It's a 22V Zener)

10) -

11) Next you can fit all the rest of the diodes.

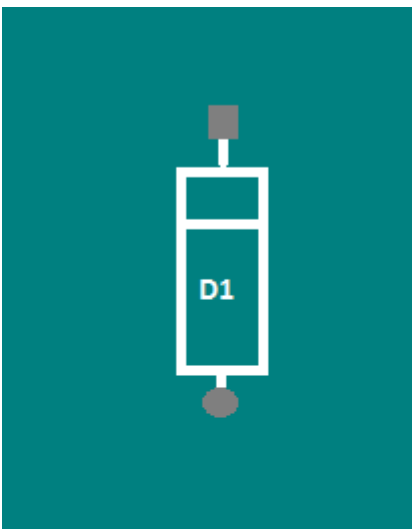
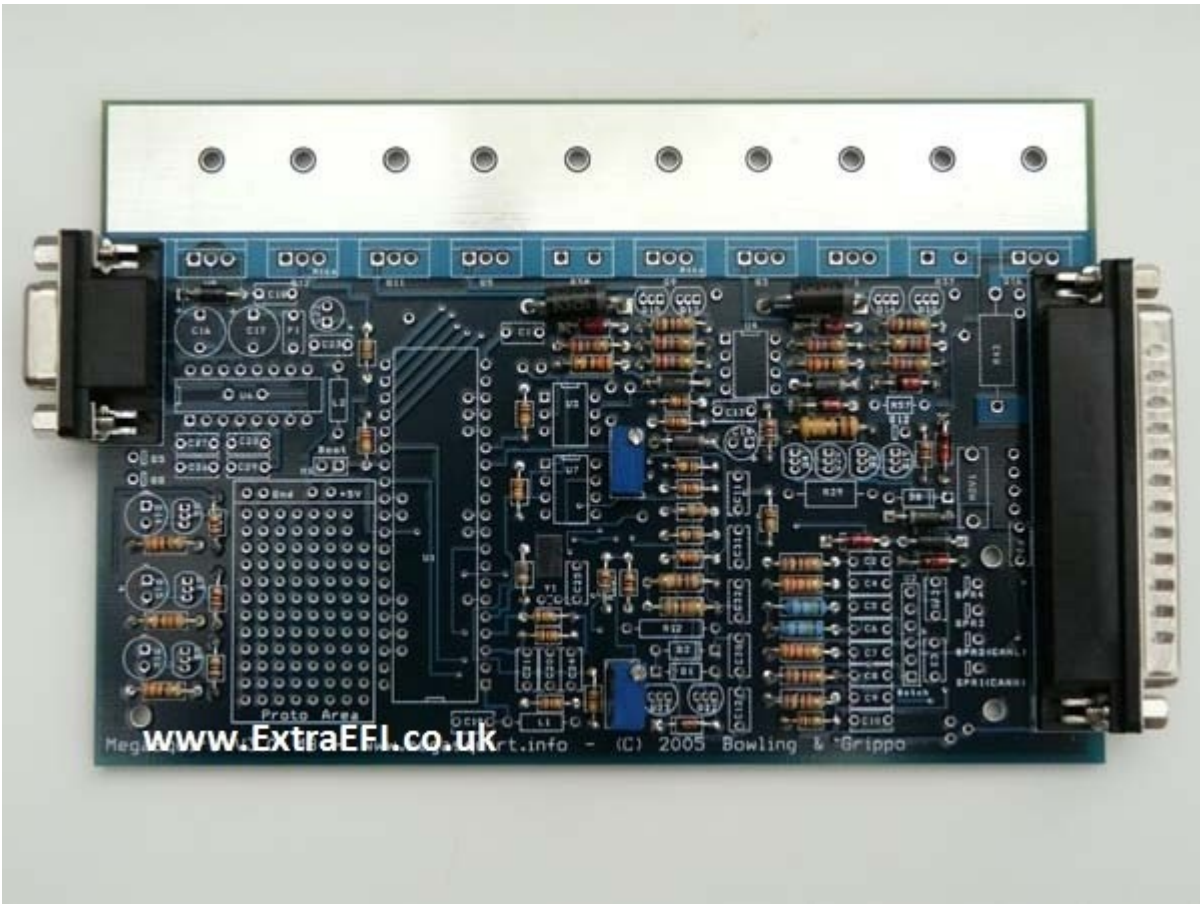

Example of trace on Board



Diode

Note the square pad on the board showing the end for the strip, as well as the trace showing the strip on it.

12) Next get all the bags of capacitors together, keeping them in the bags (C1, etc).

If you're using the coil -ve as the trigger input go to step 14 (This is rare now.) Note that you CANNOT trigger from coil negative if you are trying to run ignition or sequential fuel - you need a toothed-wheel arrangement.

13) As long as you're NOT using the coil -ve as the trigger input (Fuel only) find C30 and instead install it in H1/Boot (This adds smoothing to the battery voltage measurement and reduces the chance of noise getting injected into the CPU from the 12V line.)

14) Find C22 and C14, C16 and C17. Solder these in. Note, these are polarised, ensure the lead with the "+" next to it on the component goes into the square pad on the board, this is also labeled with a "+" on the board.

15) Now solder all the rest of the capacitors in. Solder from above.

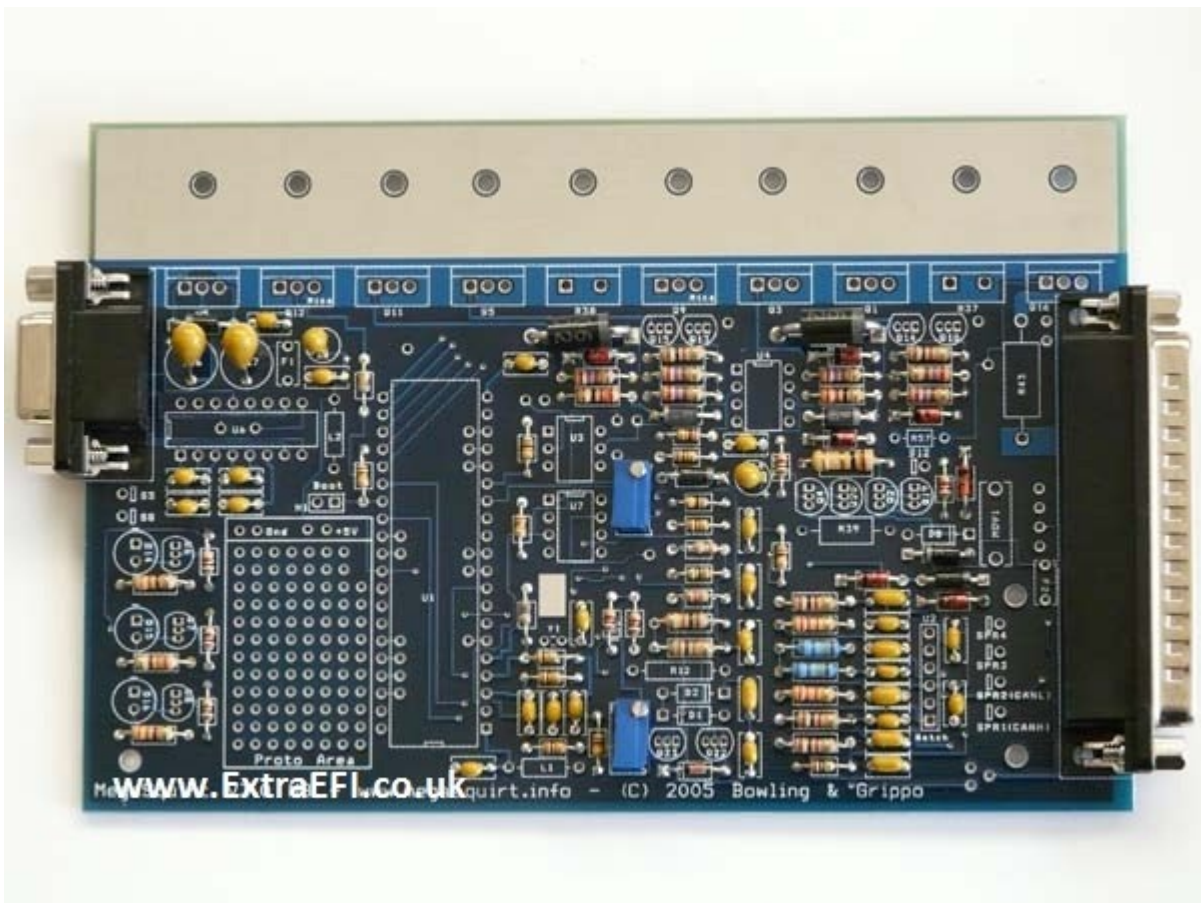

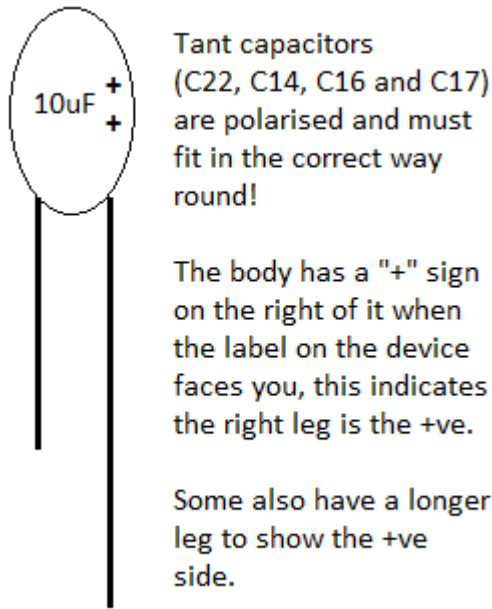

Positive Lead

15B) Solder in the two polyfuses F1 and F2. Solder in the two inductors L1 and L2, leave a little gap underneath. Solder in MOV1 (looks like a big round capacitor.) (Not shown installed in this photo.)

16) Now find the bag with all the chips in it, U6, U3, U7, U4 and the 40 pin socket for U1. Solder these in place, be careful to get them the correct way round! Also, be sure not to mix up U4 (IXDI404) and U7 (MC33072)

U7 could be one of two parts, the LM2904 works in 99% of cases though is being phased out and replaced with a substitute (MC33072) that has been shown to solve problems that a very small number of vehicles (e.g. LS1) may experience.

Note, the notch in the component must line up with the notch shown on the board. For the chips it usually works well to solder one leg in from above (to hold the part in place) then turn the board over and solder in all legs from below for a better joint and less heat into the chip.

17) Find Q16, (Ignition Transistor), D14, D15 and D16 (LEDs) Q4 and Q20 (small transistors) and MS3 CPU card. Put these to one side but don't lose them!!

18) Now place the metal strip (heatsink) in place and start fitting the main power components (U5, Q12, Q11, Q5, R38, Q9, Q3, Q1, R37), remembering Q9 and Q12 have a piece of mica insulation under them to stop them touching the heatsink!

Note, you can temporarily fit a couple of screws to hold the heatsink in place whilst you put the parts in. All power components should be fitted with a smear of thermal grease.

See step 28 before installing Q16.

TIP125, TIP122, BIP373 require a mica insulator.

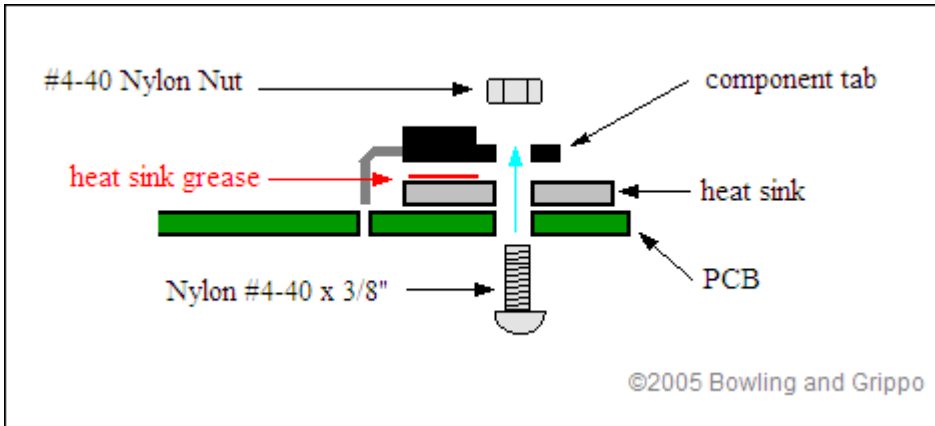

Without mica

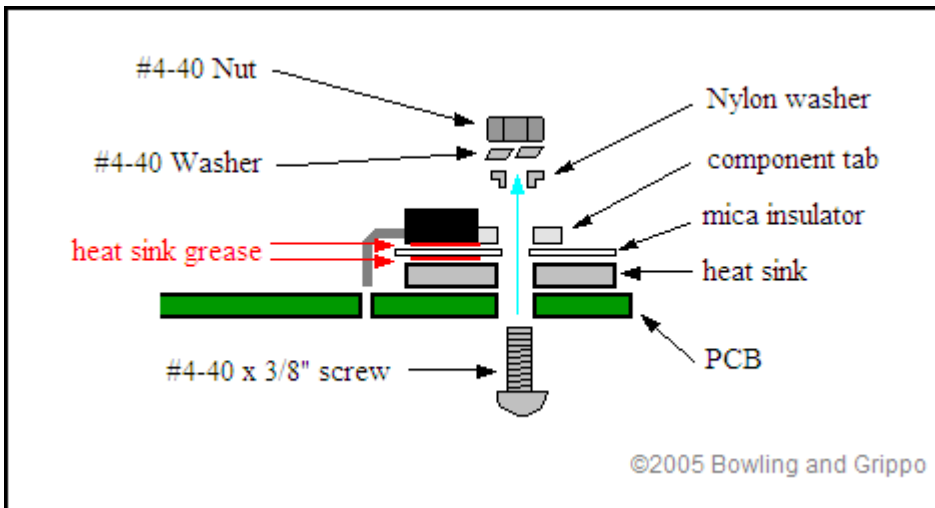

With mica



19) Find Y1 (crystal) This is not needed for MS2, but for completeness you can fit it so that the body of the crystal lays on the metal pad above the holes. You should glue this to the board or very carefully solder it so it doesn't move about.



20) You can now fit all the other components (polyfuses, MOV etc), except for those that you put to one side! I fit the MAP sensor last, don't forget to bolt it in place with the plastic screws then solder it in once it's secure. It mounts on the underside of the board. Note, if using metal screws, don't tighten them up too much or the sensor

case will distort and read incorrectly. This is installed with the writing facing you, the 'round' side goes towards the board. One of the pins has a small notch out of it which goes in the hole with 'notch' next to it.

Don't forget to install Q22, Q23.

When installing the small transistors, the rounded side of the package aligns with the rounded symbol on the circuit board. To reduce the change of the leads becoming bridged, bend the leads outwards slightly and solder the middle lead first. Double check for solder-bridges with a magnifying glass after assembly.

Note, if using the SPR1-4 connections you should install the jumper wires before the MAP sensor.

21) R37 and R38 are 'sense' resistors for the current limiting circuits on the injector drivers. Normally these should be installed.

(If, however, you prefer to do without the current limiting and want to make two spaces on the heatsink bar, then you can instead link out R37 and R38 by soldering a copper wire between the 2 holes in each. Ensure the link is flat to the board as you may need a component on the heat sink later on in the build. Remember that without these current sense resistors, there is no over-current protection on the injector circuits.)

22) R43 is intended to allow coil current to be measured if you are using the Q16 high current coil driver. Unless you have access to an oscilloscope and plan on performing this test you won't need it. Either install R43 or link it out.



13.4 Jumper wires

23) Jumper wires.

It is strongly recommended that these jumper wires are all installed as described, unless you are using the outputs for a custom modification.

CAN jumpers - top side of board.

JS6 to SPR1 (CANH)

JS8 to SPR2 (CANL)

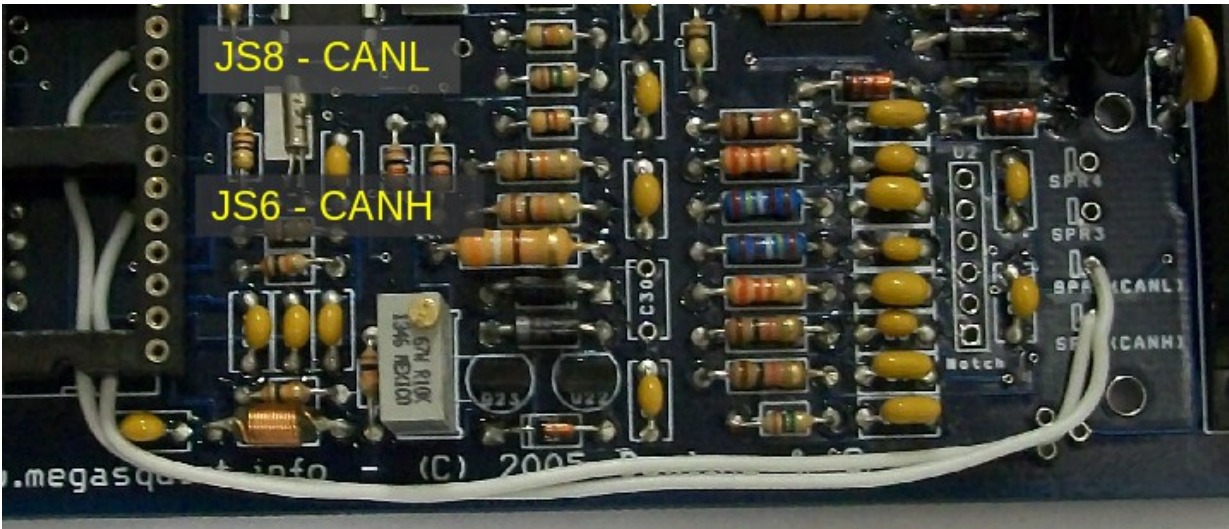

S12C to JS9 - bottom side of board

This is required to power the stepper driver.

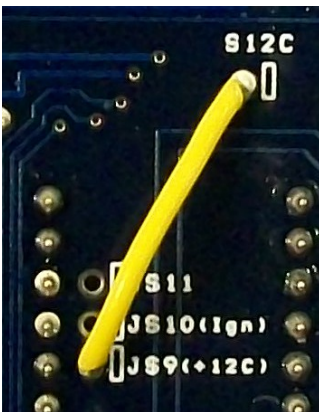

Stepper jumpers - bottom of the board

- a) JS0 to IAC1A
- b) JS1 to IAC1B
- c) JS2 to IAC2A
- d) JS3 to IAC2B

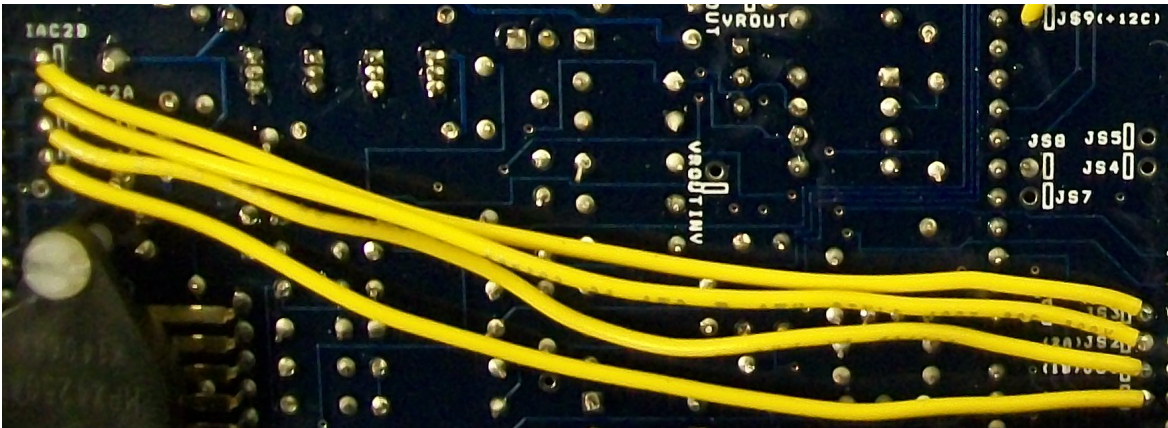

13.5 Testing Stage

24) The board is now built to a basic level and is ready for a few tests:

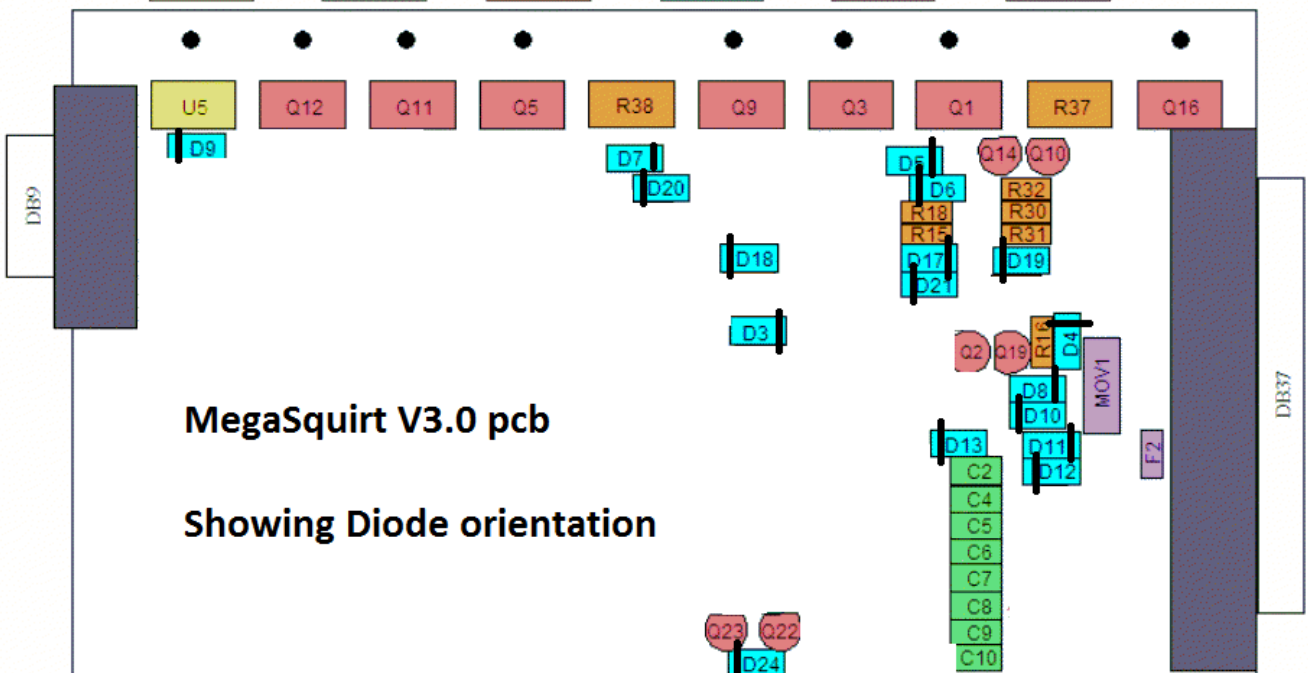

- Start by looking at ALL of the diodes and ensure they are the right way round.
- Check that you fitted the mica insulators under Q9 and Q12 on the heatsink and that they look OK.
- Now you can plug it into your Stim (in the absence of a stim, you need a loom-pigtail and a 12V DC supply with a low value fuse e.g. 1A. Check the external wiring diagram, +12V goes to pin 28 and ground to any of pins 1,2,7-19) and measure the voltage on the 40 pin connector U1:

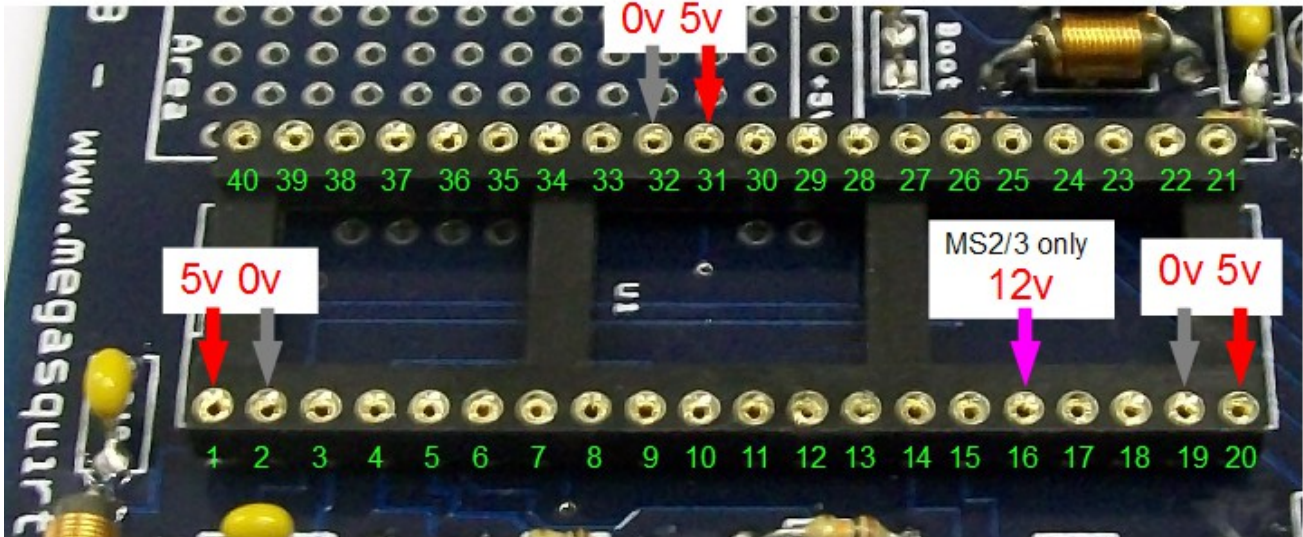

Put the -ve probe of your voltmeter on pin 32 of the 40pin connector (U1) Note, this is WITHOUT the CPU card in place!

Put the +ve probe onto pin 20 (Top pin right side)

Ensure you read 5V (+/- 0.1V)

d) Keep the +ve probe on pin 20 and move the -ve probe to pin 19 and pin 2, ensure you have 5V on the meter for both measurements. If its OK go to the next step (25).

e) If you don't get 5V then put the -ve probe on the 0V on the proto area and put the +ve probe onto the left pin of U5 (top left hand side on heatsink) check the voltage on the meter, it should be 12V (9V if using a battery) if this isn't there then you have a stim/battery problem as the ECU isn't getting any power. It could also be a diode in the wrong way round, so check D10, D11, D12 and D13!

f) If they are all OK then check the mica insulation on Q9 and Q12, with an ohmmeter (multimeter) put one probe on the metal heatsink and another on the metal tab of Q9 and Q12, you should read 300+ Ohms. If you read less then you have a short, remove the insulator and fix the issue with a new one.

If you have any smoke then its likely you've put a diode in the wrong way round, this will mean finding it and fitting a new component. Once any component smokes it is no longer any use!

g) The voltage across "Boot" jumper H1 should be one sixth (1/6) of the main voltage supply. i.e. with a 12V supply you will see 2V there.

25) LEDs. For most installs, you can proceed and install the LEDs. Only in situations where you are DIYing many spark outputs and want to fit an additional connector should they be omitted.

Temporarily fit the case end-plate to the DB9 connector - this gives you the correct alignment for the LEDs.

Take each LED and find the shorter leg, this goes to the hole marked (-) Ensuring correct orientation, bend the legs so that the LED fits through the hole in the case and the legs go into the holes in the board. Apply a little solder from above, then turn over and fully solder.

26) Idle valves:

The MS2 card has support for a 4 wire stepper idle valve built-in, just requiring the five jumpers on the mainboard in step 23.

If using 2 wire PWM idle, you will need to upgrade the 'FIDLE' circuit on the V3.0 board. (The PWM Idle Valve circuit upgrade can also be used to drive other solenoids such as boost control.)

i) Stepper Idle Valve: If using a 4 wired idle valve (or using as two spare outputs) then solder wires from:

- a) JS0 to IAC1A
- b) JS1 to IAC1B
- c) JS2 to IAC2A
- d) JS3 to IAC2B
- e) S12C to JS9

f) Solder components Q4, Q20, R39 and D8 in place. Note, this gives you a programmable output that can drive a relay e.g. cooling fan on FIdle (Pin 30 of the db37)

ii) PWM Idle Valve:

This is covered in section 3.5.4.2

iii) No Idle Valve:

a) Solder components Q4, Q20, R39 and D8 in place. Note, this gives you a programmable output that can drive a relay e.g. cooling fan relay on FIdle (Pin 30 of the db37)

27) Tach input(s): See section 5.2

28) Spark output(s): See section 5.3.0

29) Next we need to check that everything is OK before we plug in the microprocessor. Plug the mainboard into your stim (or 12V supply as in step 24c) and power it up.

Ensure you have 0-5V on TSEL, if you get any more than 5V you have a wiring issue with the trigger input side which would likely destroy the MS2 CPU card. As long as you have 0-5V you can proceed to step 30.

30) Now your ready to test the board with the microprocessor in place. Fit the MS2 CPU card into socket U1 noting orientation. JP1 on the card is near www.megasquirt.info on the mainboard.

Plug the ECU into your stim and turn the power on.

Feel the top row of power transistors, if they get hot at all turn the power off and check for faults.

If the microprocessor gets hot then turn it off. Slightly warm is OK, if any part is too hot to touch then there is a fault!

31) You can now assemble the ECU into the case. The mainboard fits into the upper slot of the lower half of the case. The hex screws on the plugs are 3/16" AF.

32) You are now ready to load the MS2/Extra firmware and follow the other steps in the Quickstart guide contained within the Setting Up Manual.

13.6 Optional low-z injector PWM modification

Some installs using low impedance injectors and PWM current limiting may experience tach noise problems or processor resets. Try the following noise reduction mods.

1. Cut the center leg on Q9 and Q12 or desolder it so it does not reach the PCB.
2. Run a length of jumper wire from the center leg of Q9 and Q12 to an unused pin on the DB37 connector.
3. Wire this pin to a 12 volt source in the wiring harness, separate from the Megasquirt's power supply wire.
4. Solder a 0.1 uF capacitor in the H1 (boot) header on the main board.

13.7 Bill of Materials (parts list)

Here are the parts used to assemble the V3.0 main board.

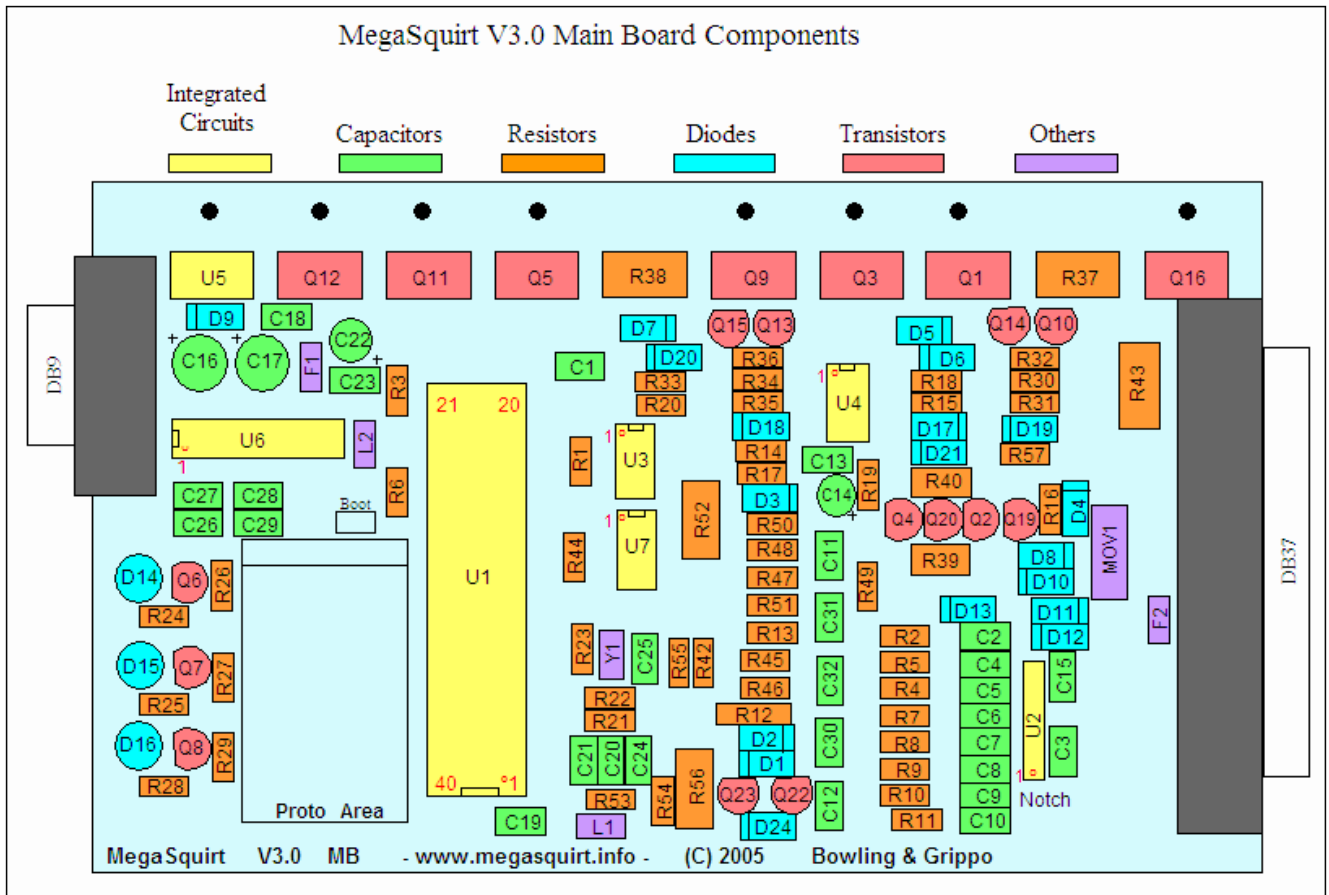

Please note that these Digikey part numbers are provided for reference only, other suppliers are available and parts numbers will be superseded over time.

Qty	Ref	Desc.	Part no.	Notes
10	C1,C3,C13,C18,C19, C23,C26,C27, C28, C29	Capacitor 0.1µF 50V 10% CER RADIAL - X7R	399-4329-ND	
3	C11,C21*,C32	Capacitor 0.01µF 50V 10% CER RADIAL	399-2075-ND or 399-4326-ND	
2	C16,C17	Capacitor TANT 22µF 25V 10% RAD	399-1420-ND or 399-3584-ND	
4	C2,C9, C10, C30	Capacitor 0.22µF 50V 10% CER RADIAL - X7R	399-2083-ND or 399-4353-ND	
1	C31	Capacitor 0.001µF 50V 10% CER RADIAL - X7R	399-2017-ND	
1	C20*	Capacitor 0.033µF 50V 10% CER RADIAL	399-4361-ND	MS1 only
2	C14,C22	Capacitor TANT 4.7µF 25V 10% RAD	399-3559-ND	
1	C24*	Capacitor 47PF 200V 5% CER RADIAL	399-1911-ND	MS1 only
1	C25*	Capacitor 22PF 200V 5% CER	399-1908-ND	MS1 only

Qty	Ref	Desc.	Part no.	Notes
		RADIAL		
5	C4,C6,C8,C12,C15	Capacitor 0.001 μ F 100V 10% CER RADIAL - X7R	399-4202-ND	
2	C5,C7	Capacitor 1.0 μ F 50V 10% CER RADIAL - X7R	399-2102-ND or 399-4389-ND	
7	D1-3,D9-11	Diode GPP 50V 1A DO-41	1N4001DICT-ND	
1	D12	Diode Zener 24V 1W 5% DO-41	1N4749ADICT-ND	
1	D13	Diode Zener 12V 1W 5% DO-41	1N4742ADICT-ND	
3	D14,D15,D16	LED Red Translucent Round	67-1102-ND	
2	D17,D18	Diode Schottky 40V 1A DO-41	1N5819DICT-ND	
1	D19	Diode Zener 5.6V 1W 5% DO-41	1N4734ADICT-ND	
3	D4,D8, (D2 coil-)	Diode Zener 22V 1W 5% DO-41	1N4748ADICT-ND	
2	D5,D7	Diode FAST REC 100V 3A DO- 201AD	FR302DICT-ND	Active flyback
3	D6,D20,D21	Diode Zener 36V 1W 5% DO-41	1N4753ADICT-ND	
1	D24	Diode 1N4148	1N4148DICT-ND	
2	F1, F2	Polyswitch RXE Series 0.50A HOLD	RXEF050-ND	
2	L1,L2	Choke RF Varnished 1UH 20%	M8388-ND	
1	MOV1	Surge absorber 20MM 22V 2000A ZNR	P7315-ND	
1	P1	Connector D-SUB RECPT R/A 9POS PCB AU	A23305- ND/A32119-ND	
1	P2	Connector D-SUB PLUG R/A 37POS PCB AU	A23289-ND or A32103-ND	
2	Q1,Q5	HEX/MOSFET N-CH 60V 20A TO- 220FP	IRFIZ34GPBF-ND	
1	Q16	Ignition driver BIP373 TO220	N/A	High-Current Ignition Driver
2	Q2,Q4	Transistor NPN 45V 1000MA TO- 92	ZTX450-ND	
2	Q22,Q23	Transistor PNP 100V 1000MA TO- 92	ZTX553-ND	
2	Q3,Q11	Transistor PNP 6A 100V HI PWR TO220AB	497-2629-5-ND	

Qty	Ref	Desc.	Part no.	Notes
9	Q6,Q7,Q8,Q10,Q13, Q14,Q15,Q19,Q20	Transistor NPN SS GP 200MA TO-92	2N3904FS-ND	
2	Q9,Q12	Transistor PNP DARL -100V -5A TO-220	TIP125TU-ND	Active flyback
7	R16,R19,R26,R27, R29	Resistor 1.0K Ohm 1/8W 5% Carbon Film	1.0KEBK-ND	
2	R42,R55	Resistor 10K Ohm 1/8W 5% Carbon Film (or 1.0K)	10KEBK-ND (or 1.0KEBK-ND)	
9	R1*,R6,R14,R17,R21*, R44,R48,R53,R54	Resistor 10K Ohm 1/8W 5% Carbon Film	10KEBK-ND	
5	R2,R9,R10,R32,R36	Resistor 1.0K Ohm ¼W 5% Carbon Film	1.0KQBK-ND	
3	R22*,R49,R50	Resistor 100K Ohm 1/8W 5% Carbon Film	100KEBK-ND	
2	R11,R51	Resistor 1.0M Ohm 1/8W 5% Carbon Film	1.0MEBK-ND	
1	R23*	Resistor 10M Ohm 1/8W 5% Carbon Film	10MEBK-ND	MS1 only
2	R15,R20	Resistor 22 Ohm ¼W 5% Carbon Film	22QBK-ND	
2	R4,R7	Resistor 2.49K Ohm ¼W 1% Metal Film	2.49KXBK-ND	
6	R18,R30,R31,R33, R34,R35	Resistor 270 Ohm ¼W 5% Carbon Film	270QBK-ND	
3	R24,R25,R28	Resistor 330 Ohm ¼W 5% Carbon Film	330QBK-ND	
1	R12	Resistor 390 Ohm ½W 5% Carbon Film	390H-ND	
1	R13	Resistor 4.7K Ohm 1/8W 5% Carbon Film	4.7KEBK-ND	
1	R3	Resistor 51K Ohm 1/8W 5% Carbon Film	51KEBK-ND	
2	R37,R38	Resistor .05 Ohm 20W TO220	TAH20PR050J-ND	Current Limiting
2	R39,R40	Resistor 1.0 Ohm ½W 5% Carbon Film	1.0H-ND	
1	R43	Resistor Current Sense .010 Ohm	13FR010-ND	High-Current

Qty	Ref	Desc.	Part no.	Notes
		3W		Ignition Driver
2	R45, R46	Resistor 10K Ohm ¼W 5% Carbon Film	10KQBK-ND	
1	R47	Resistor 47K Ohm 1/8W 5% Carbon Film	47KEBK-ND	
2	R5,R8	Resistor 2.2K Ohm ¼W 5% Carbon Film	2.2KQBK-ND	
1	R52	Trim Pot 100K Ohm TOP ADJ	CT94W104-ND	
1	R56	Trim Pot 10K Ohm TOP ADJ	CT94W103-ND	
1	U3	Optoisolator w/base 6-DIP	160-1300-5-ND	
1	U4	MOSFET Driver LS 4A DUAL 8DIP	IXDI404PI-ND	
1	U5	Regulator LDO TO-220	LM2937ET-5.0-ND	
1	U6	DVR/RCVR 5V RS232 16 DIP	497-2055-5-ND	
1	U7	OpAmp Dual SGL SUPP HS 8DIP	(LM2904NFS-ND) MC33072PGOS-ND or 296-7112-5-ND or MCP6002-I/P-ND	
1	Y1*	Crystal 32.768KHz CYL 12.5PF	300-1002-ND	MS1 only
2	NA	Insulating kit TO-220	4724K-ND	
1	NA	Socket Machine Pin ST 40POS GOLD	AE7240-ND or AE10018-ND	
1	Optional	Socket Machine Pin ST 16POS GOLD (Max232)	AE7216-ND or AE10013-ND	Optional socket
2	Optional	Socket Machine Pin ST 8POS GOLD (IXDI404PI)	AE7208-ND or AE10011-ND	Optional socket
1	Optional	Socket Machine Pin ST 6POS GOLD (4N25)	AE7300-ND or AE10021-ND	Optional socket
1	NA	Connector DB-37 Female;	237F-ND	Cables
1	NA	DB-37 Hood;	937GM-ND	Cables

* = MS1 only. The 32kHz crystal and circuit are not used on MS2 or MS3 installs.

14 Revision history

2014-07-19	Revision history started
2014-07-21	Re-worded logic spark resistor vs. TC4427 sections. Replaced missing images for EDIS, HEI7. Updated some mainboard pictures.
2014-07-23	Added Quadspark wiring diagram.
2014-08-05	Correct typo "trigger wheel" -> "toothed wheel". Added chapter index. Remove spurious note about a top nitrous relay.
2014-08-11	Flip 4G63 tach-in. Add note about tach-in polarity for ref.
2014-08-29	Rename as Manual. Renew external wiring diagram and use DIYAutoTune.com colours.
2014-12-01	Apply auto-numbering.
	Add new CAN wiring diagram. Add 4-wire O2 sensor pic. Update TFI, HEI, 420A, 36-2+2, Miata 99-05, 6G72, 4G63, LS1 input polarities per DIYA. Add V3.0 BOM.
	Update JS4/5 spark outputs.
2014-12-05	Correct references to ignition circuit building sections.
2014-12-08	Fixed minimal wiring diag.
2014-12-10	Low-z injector flyback mod. Add an inputs/outputs summary table.
2015-02-02	Fix EDIS images. Add photos for IAC, CAN, S12C jumper wires, JP7 setting. Add photos of tach in 'VR' circuit threshold setting. Relay board section. Add ground-switch cam in. Add pin usage table.
2015-02-16	SPR1,2 CANH/L
2015-02-27	JS7 CANL typo
2015-04-02	V3 board layout image missing
2015-05-05	Correct HEI7/8 output polarity setting.
2016-01-15	Correct JS10 typo error in i/o summary table. Add ignition system design section. Add Boot H1 voltage testing note.