

Fits following cars:  
 Golf5 / Jetta5 / Audi TT2/ A3 /  
 Passat 3.6  
 2.0T / 2.5 / R32

# VW / AUDI type 5 chassis Transmission Side Mount (US-Driver side), 4 / 6 CYLINDER MODELS

Fitting notes:

- 1) **WARNING: DO NOT LOOSEN OFF ENGINE MOUNTING BOLTS IF ENGINE IS NOT SUPPORTED FROM BELOW.**
- 2) **IF YOU ARE INSTALLING BOTH SIDE MOUNTS: ONLY INSTALL ONE SIDE MOUNT AT A TIME. THIS PREVENTS MISALIGNMENT OF THE ENGINE IN THE LEFT-TO-RIGHT AXIS.**
- 3) Support engine from below. You will need to remove the airbox and battery and loosen off the wiring harness guide that's runs over the mount. Loosen off and remove the Engine side mount. **DO NOT WORK UNDER CAR OR KEEP CAR RAISED UNLESS SAFELY SUPPORTED ON STANDS.**
- 4) Fit the new VF mount exactly in place of the original mount. All holes should line up and the mount edges should sit parallel to the OEM casting.
- 5) Check torque settings after 200 miles. **IF IN DOUBT CONSULT WORKSHOP MANUAL / VF-TECHNICAL. DO NOT INSTALL THIS PART WITHOUT USING A TORQUE WRENCH.**

Bolts A - Mount to Body bolt 40Nm (30 ft-lbs)  
 Bolt B - Mount to engine bracket bolt 60 Nm (44 ft-lbs)  
**BOLT IN CENTER OF VF-MOUNT TO BE TORQUED TO 40Nm (30 ft-lbs)**

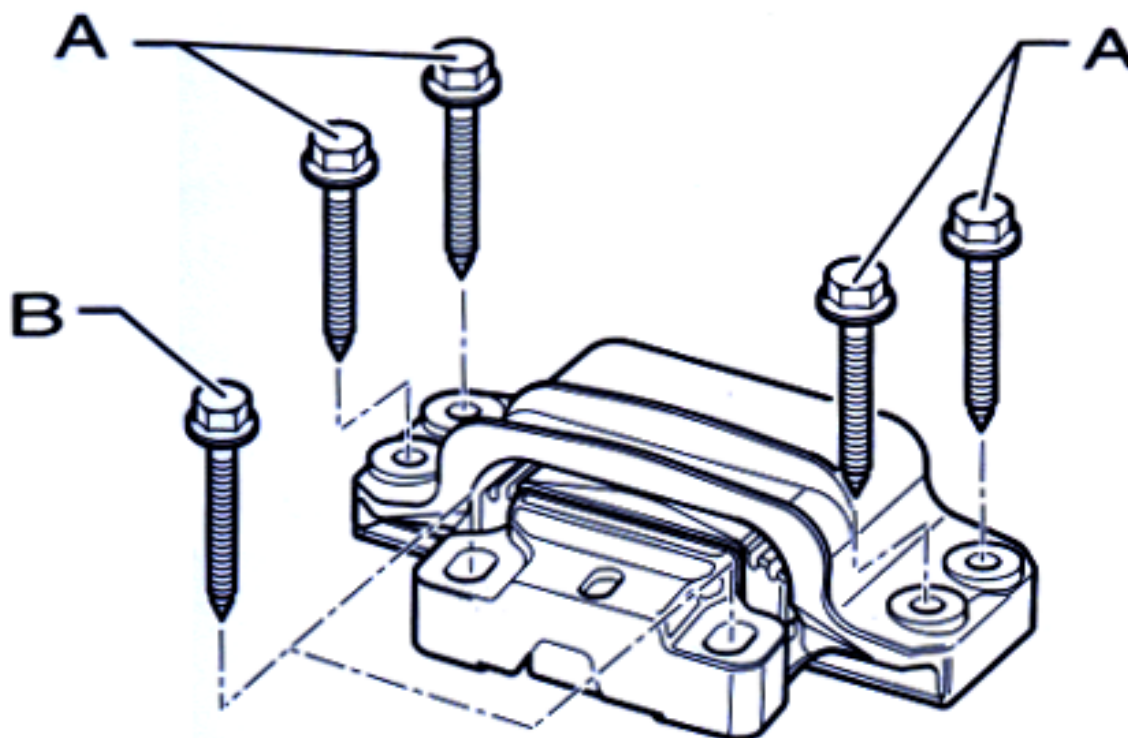

**Warranty:** 12 months or 12,000 miles whichever occurs sooner on defective VF parts only. No liability is accepted for consequential damage/ cost, misused or misfitted parts. For off-road use only. If in doubt do not fit part and consult retailer.

THE PRODUCT AND INFORMATION SUPPLIED IS THE SOLE PROPERTY OF ZURICH ENGINEERING, INC. ANY REPRODUCTION IN PART OR WHOLE WITHOUT THE WRITTEN PERMISSION OF ZURICH ENGINEERING, INC. IS PROHIBITED.

	MANF BY	<b>Zurich Engineering, Inc.</b>
	12 JUL 06	
TOLERANCE		<a href="http://www.vf-engineering.com">www.vf-engineering.com</a>
DRAWN	MFG ENG	<b>VF PART #VFA06-04</b>