



QUALITY... PLAIN & SIMPLE®

**Back-Up Light or Neutral Safety Switch Kit
Installation Instructions**

Back-Up Light or Neutral Safety Switch Kit Installation Instructions

Building American Quality... With A Lifetime Warranty!®

TOLL FREE 1-877-469-7440 • tech@lokar.com • www.lokar.com

General Installation Notes:

Please read instructions completely before beginning installation. If you have any questions please call.

Before starting installation, use wheel chocks to block the vehicle's wheels. Do not attempt to install this product while the engine is running. Disconnect the negative battery cable before beginning installation.

Make sure the engine, transmission, body and frame are properly grounded.

NOTE: This kit offers the choice of Back-Up Light Switch OR Neutral Safety Switch, Not Both!

Refer to Fig. 1 for the component names.

Switch Installation:

Step 1: Install the bracket with the switch:

• **For TH350, TH400, and TH200 Applications:** Some of these transmissions use standard bolts for the transmission oil pan, while others use metric bolts. Both standard 5/16"-18 x 1-1/4" and metric M8 x 30mm bolts have been included in this kit. Determine which pair matches the thread pitch on the pan bolts you removed from the transmission, and discard the other two new bolts.

Install the correct thread transmission pan bolts from the Lokar kit, with the 3/8" thick spacers between the bracket and the transmission pan. Use the flat washers and lock washers on the bottom side of the bracket, as shown in Fig. 2.

• **For 700-R4, 200-4R, and 4L60 Applications:** Install the 1/4" spacers and two metric bolts supplied with the Lokar kit. Use the flat washers and lock washers on the bottom side of the bracket, as shown in Fig. 2.

Switch Wiring:

The switch is a non-directional, normally open, spring loaded ball switch. It makes contact and passes current when the ball is depressed. For some common applications, you will be cutting a single wire, and simply connecting the cut ends to the switch terminals.

For Use as a Neutral Safety Switch

Step 2: Put the transmission in Park and install the double trigger as shown in Fig. 2, with the 3/8" internal star washer between the trigger and your original nut. Position the trigger so that the ball switch is depressed in Park. The double trigger should also depress the ball switch when transmission is in the Neutral position.

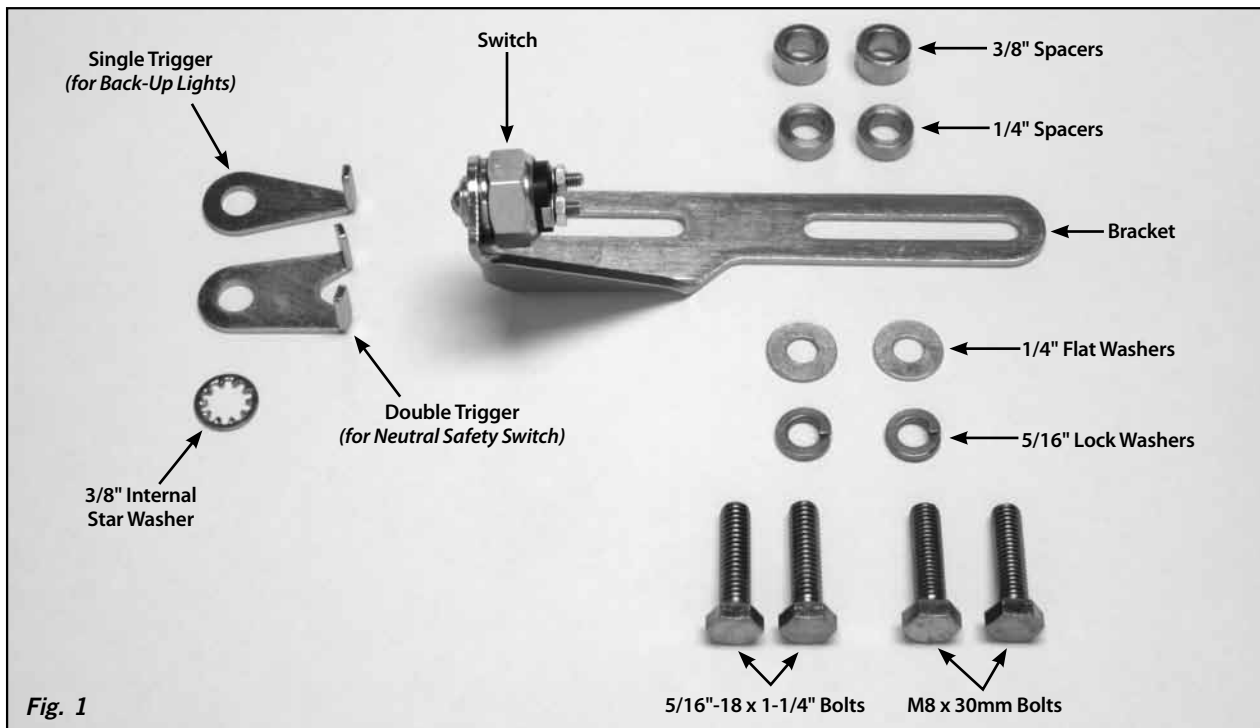

Fig. 1

Step 3: Connect the switch between your ignition switch and starter circuits. Check the wiring of your fuse panel.

- If there are (2) connections for a neutral safety switch, you must run a #12 (or heavier) stranded wire from these terminals to the (2) terminals on the neutral safety switch. That completes the neutral safety switch wiring.
- If your wiring panel does not have neutral safety switch connections, you will have to locate the wire going from the ignition switch to the starter. If GM color codes are used, this wire will usually be **PURPLE**. After locating the wire, it must be cut and routed from the ignition switch to one of the neutral safety switch terminals, and from the second neutral safety switch terminal to the same stud on the starter where the original wire was removed. If the wire must be lengthened, be sure to use wire that is at least the same size or larger than the original.

Reconnect the negative battery cable and check operation.

For Use as a Back-Up Light Switch

Step 2: Install the single trigger onto the transmission gear selector shaft, with the 3/8" internal star washer between the trigger and your original nut. Put the transmission in Reverse and make sure the ball switch is depressed. See Fig. 2

Step 3: Check the wiring of your fuse panel.

- If there is a connection for back-up lights on your fuse panel, you may run a 16 gauge (or heavier) wire from the fuse panel terminal to either of the back-up light switch terminals. Run a second wire from the other backup light switch terminal to your back-up lights. Be sure the back-up lights have a good chassis ground.
- If there is no connection for back-up lights on your fuse panel, you may connect a wire from the headlight switch "taillight" terminal to either of the backup light switch terminals, and then run a second wire from the other backup light switch terminal to your back-up lights. If your vehicle uses standard GM wiring, the taillight wire will usually be **BROWN**.

Reconnect the negative battery cable and check operation.

