

INSTRUCTION SHEET

Delco Alternator Low Mount Bracket SB Chevy 885, 1885, 2885

We want to help! If you have any comments or difficulty with this product, please contact technical support at



7501 Strawberry Plains Pike
Knoxville, TN 37924

(865) 688-5953 ext 1250

FAX: (865) 281-9844

e-mail: tech@powermastermotorsports.com

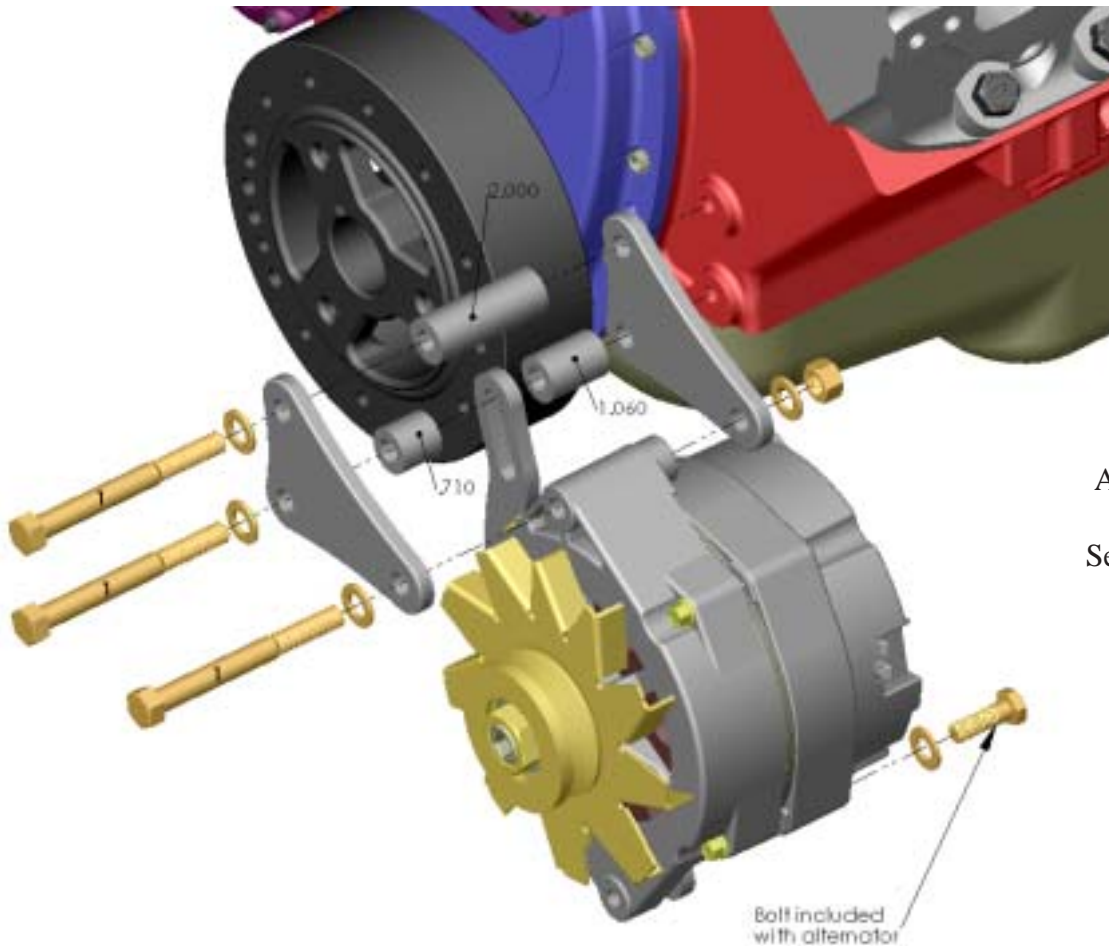
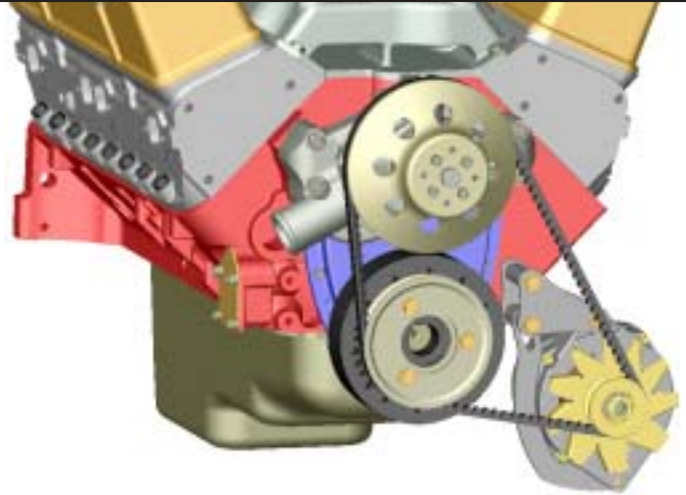

Assembly per illustration.

See reverse side for special notes and instructions

Diagram Ref. #	Part Description	P/N 885 Qty.	P/N 1885 Qty.	P/N 2885 Qty.
	885 triangle bracket	2	2	2
	885 slotted bracket	1	1	1
1	3/8"-16 X 3 1/4" bolt	3	3	3
	3/8" flat washer	4	4	4
	5/16" flat washer	1	1	1
	3/8"-16 nut	1	1	1
	25/64" ID X 3/4" OD X 2.00" spacer	1	1	1
	25/64" ID X 3/4" OD X 1.06" spacer	1	1	1
	25/64" ID X 3/4" OD X 0.71" spacer	1	1	1

Special Notes:

- * This bracket is designed to work with most Delco10DN, 10SI, and 12SI style alternators.
- * This bracket can be assembled and mounted on either side of the crank pulley.
- * This system can be used with electric or short mechanical water pumps.
- * This bracket can be used with most manufacturer's crank and water pump pulleys as long as proper belt alignment is maintained.
- * Tension the belt to have ½" of deflection.
- * ***One wire*** alternators require only the charge wire connection to function. An adequate charge wire should be run between the alternator and the positive battery post or the positive battery side of the safety cut off switch. If the alternator's charge wire is connected to the starter's battery connection or on any other positive point on the car that is on the switched side of the cutoff, the car may continue to run after the cutoff switch is opened.
- * Be certain that any paint or corrosion is removed from the points where the bracket attaches to the engine block. Also be certain that an adequate ground path is supplied from the engine block to the negative battery post.