

ROUGH COUNTRY

SUSPENSION SYSTEMS®

JEEP 2007-18 JK 4-Door Fabbed Step

Thank you for choosing Rough Country

Please read instructions before beginning installation. Check the kit hardware against the parts list and product layout. Be sure you have all needed parts and know where they go. Also please review tools needed list and make sure you have needed tools. If question exist we will be happy to answer any questions concerning the design, function, and correct use of this product.

▲ NOTICE Does not fit 2018 JL models!

INSTALLATION

1. Place vehicle on a flat surface and set emergency brake.
2. Attach the steps to the main rail using the supplied 6mm x 20mm bolts, flat washers and lock washers (4 per step) . **See Photo 1.**
3. Tighten using a 10mm wrench. Torque to 5ft-lbs. **See Photo 2.**



4. **▲ NOTICE** Notice bracket position in **Photo 3**, rear bracket has notch to clear the body mount and the center bracket is the longest.
5. Install the mounting bracket on the main rail using the supplied 8mm x 20mm bolts, washers, and lock washers (2 per bracket). **See Photo 4.**

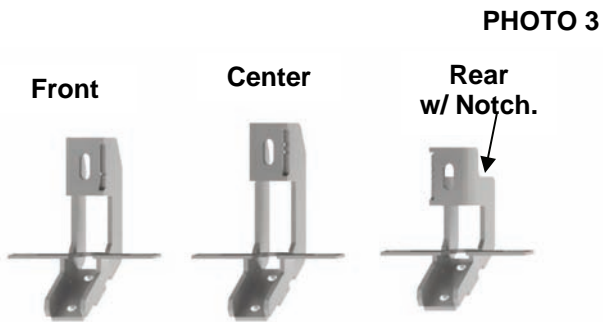

6. Tighten using a 13mm socket. Torque to 18ft-lbs. **See Photo 5.**

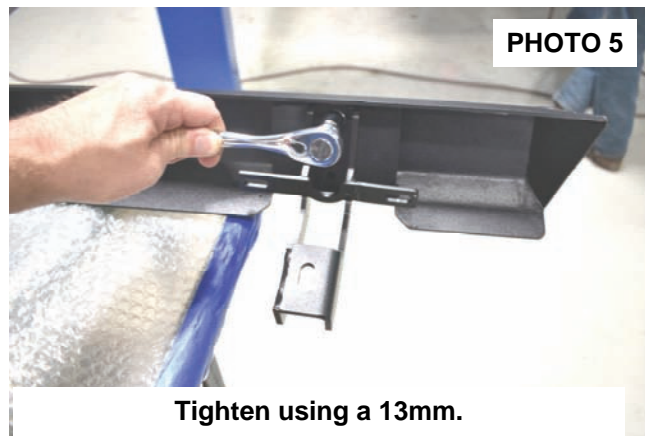

7. Repeat this process for the 5 remaining mounting brackets. **See PHOTO 6.**

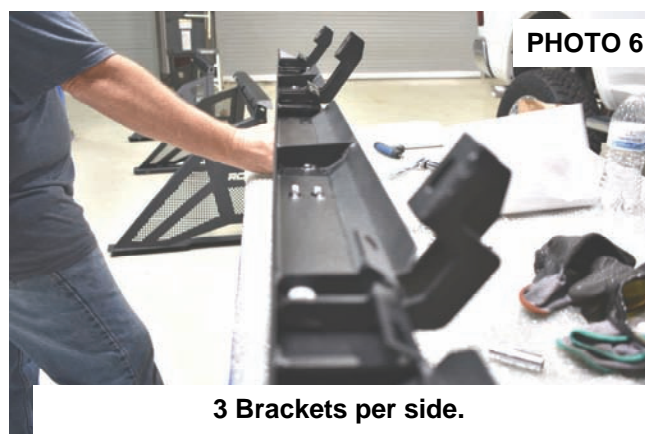

7. Attach the step mounting bracket to the underside of the floor pan. If your Jeep has the threaded inserts use the supplied 8mm x 35mm bolts, flat washers, and lock washers(1 per bracket). Torque to 18ft-lbs using a 13mm socket. **See Photo 7.**
8. If your Jeep doesn't have the threaded inserts use the supplied 3/8" clip nuts, 3/8" x 1.25" bolts, flat washers, and lock washers (1 per bracket). Torque to 30ft-lbs using a 9/16" socket. **See Photo 7.**



9. Attach the brackets to the pinch weld using the supplied 6mm x 20mm bolts (2 per bracket), flat washers on the bolt head and nut (4 per bracket), and nylock nuts (2 per bracket). Tighten using a 10mm socket and 10mm wrench. Torque to 5ft-lbs. **See Photo 8.**

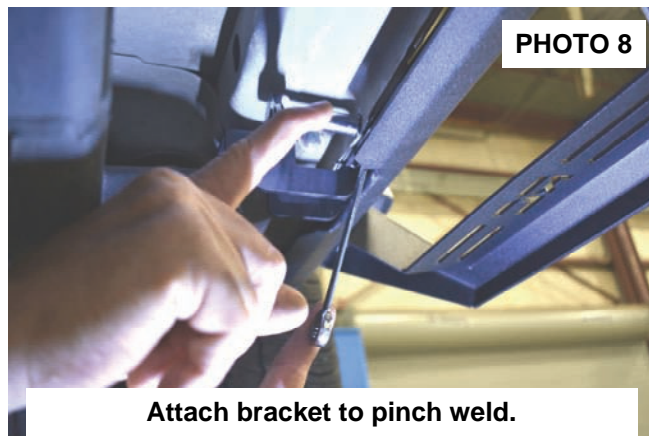

Torque Specs:

Size	Grade 5	Grade 8
5/16"	15 ft/lbs	20 ft/lbs
3/8"	30 ft/lbs	35 ft/lbs
7/16"	45 ft/lbs	60 ft/lbs
1/2"	65 ft/lbs	90 ft/lbs
9/16"	95 ft/lbs	130 ft/lbs
5/8"	135 ft/lbs	175 ft/lbs
3/4"	185 ft/lbs	280 ft/lbs
	Class 8.8	Class 10.9
6MM	5 ft/lbs	9 ft/lbs
8MM	18ft/lbs	23 ft/lbs
10MM	32ft/lbs	45ft/lbs
12MM	55ft/lbs	75ft/lbs
14MM	85ft/lbs	120ft/lbs
16MM	130ft/lbs	165ft/lbs
18MM	170ft/lbs	240ft/lbs



Kit Contents:

- 1- Dr Main Step Rail
- 1- Pass Main Step Rail
- 4- Steps
- 2- Front Step Mounting Brackets
- 2- Center Step Mounting Brackets
- 2- Rear Step Mounting Brackets
- 1- 90765Bag including:
 - 6- 3/8" Clip Nuts
 - 6- 3/8" Lock Washers
 - 6- 3/8" x 1.25" Bolts
 - 6- 3/8" Flat Washers
 - 6- 8mm x 35mm Bolts
 - 18- 8mm Flat Washers
 - 12- 8mm x 20mm Bolts
 - 18- 8mm Lock Washers
 - 28- 6mm x 20mm Bolts
 - 12- 6mm Nylock Nuts
 - 40- 6mm Flat Washers
 - 16- 6mm Lock Washers

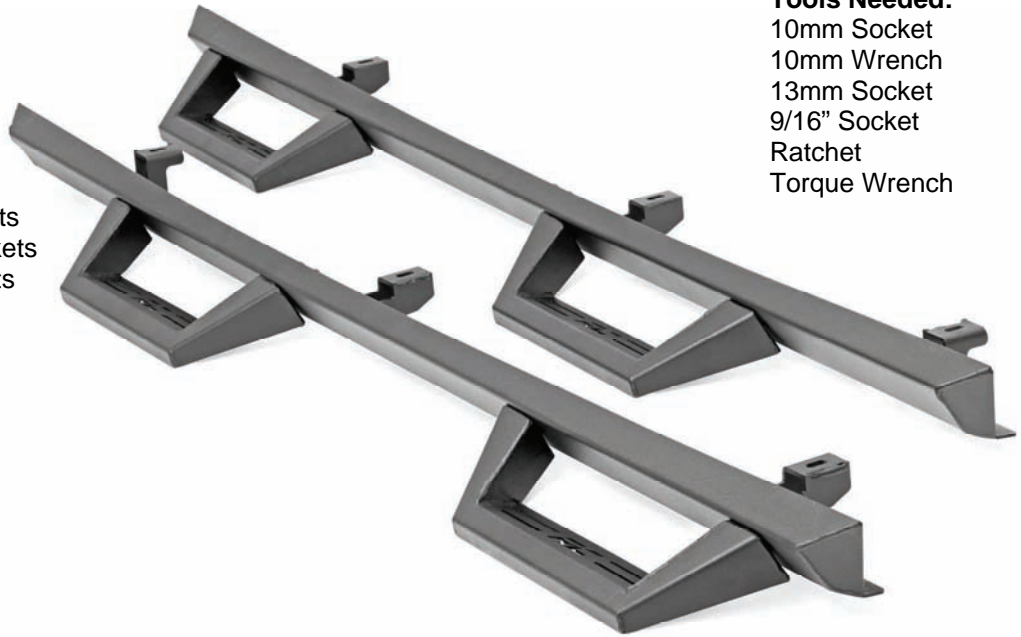
**Tools Needed:**

- 10mm Socket
- 10mm Wrench
- 13mm Socket
- 9/16" Socket
- Ratchet
- Torque Wrench



THANK YOU FOR CHOOSING ROUGH COUNTRY FOR YOUR OFF ROAD NEEDS.

By purchasing any item sold by Rough Country, LLC, the buyer expressly warrants that he/she is in compliance with all applicable , State, and Local laws and regulations regarding the purchase, ownership, and use of the item. It shall be the buyers responsibility to comply with all Federal, State and Local laws governing the sales of any items listed, illustrated or sold. The buyer expressly agrees to indemnify and hold harmless Rough Country, LLC for all claims resulting directly or indirectly from the purchase, ownership, or use of the items.

