



INSTALLATION INSTRUCTIONS P/N 63895

PARTS LIST

1- Power Steering Pump Bracket
2- 3/8 x 1-5/8" Hex Head Bolts
2- 3/8" Lock Washers

6- Alum. Spacers
2- 3/8" Flat Washers
1- 3/8 x 1-5/8" Bolt

This kit mounts the power steering pump to the driver side (left) cylinder head, using the factory bolt pattern.

NOTE: If your cylinder head does not have the required holes it will be necessary to drill and tap the pattern yourself. Use the power steering pump bracket as a template and transfer punch the location on the head. Drill holes to 5/16" diameter and tap 3/8"-16 to 1/2" minimum depth. Sealer must be used on bolts in the event of breaking through into the water jacket.

INSTALLATION

1. Line the bracket up with the bolt pattern on the cylinder head.
2. Attach the bracket with the supplied hardware. Use the spacers supplied with the kit to space the bracket out for proper belt alignment. See the illustration below for proper spacer and bolt placement.

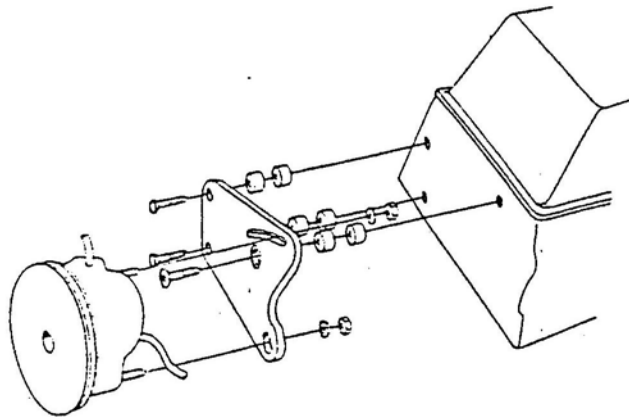

**For Technical Assistance, Call Moroso's Tech Line at
(203) 458-0542, 8:30am – 5:00pm Eastern Time**

MOROSO PERFORMANCE PRODUCTS, INC
80 CARTER DR • GUILFORD, CT 06437-2116
Phone: (203) 453-6571 • Fax: (203) 453-6906