

IMPORTANT: The net amount of ride height increase depends upon the age and use of the vehicle, wheel offset, and numerous other factors. Stated torsion bar ride height increases are based upon factory specifications. If the torsion bars were “cranked up” at some point in the past, expect a corresponding reduction in overall height increase with the new torsion keys. Note that torsion bars, like any other spring, are subject to fatigue and sagging over time. Also, torsion bars have different ratings depending on how the vehicle was equipped from the factory. In some cases, installing heavier rated bars (which can be purchased from a dealer) may be the only solution to regaining ride height lost from adding heavy aftermarket accessories, such as a winch bumper or snow plow.



CL221

1988-06 CHEVY K10-20 6 LUG 4WD

1992-00 FULL-SIZE BLAZER/SUBURBAN 4WD

**2000-06 AVALANCHE/TAHOE/YUKON/
ESCALADE/SUBURBAN WD**

TORSION BAR LEVELING KIT

TOOLS NEEDED

Floor Jack X 1
Jack Stands X 2
Puller Tool X 1
Hand Tools
18mm socket and wrench

BILL OF MATERIALS

TKP11322 X 2 Torsion Keys
INSCL221 X 1 Instructions

NOTE: Various types of puller tools are available, however, due to the extreme loads present in four-wheel drive suspension systems, we have found the two-jaw style tool that clamps to the crossmember tends to slip and damage the crossmember. A C-clamp style puller tool is preferred and available through tool companies such as OTC and Kent Moore.



www.trailmastersuspension.com

www.trailmastersuspension.com

Tech Support Contact Info

Tech@trailmastersuspension.com

Phone: 928-636-7080

Fax: 928-636-7079

3651 N US HWY 89

Chino Valley, AZ 86323

Instruction Sheet insCL221
2008 Trail Master Suspension

Thank you for choosing Trail Master Suspension

Trail Master Suspension recommends a certified technician install this system. In addition to these instructions, professional knowledge of disassembly/reassembly procedures as well as post installation checks must be known. Attempts to install this system without this knowledge and expertise may jeopardize the integrity and/or operating of the vehicle.

Please read all the instructions before beginning the installation. Check the kit hardware against the parts list. Be sure you have all the needed parts and understand where they go. If anything is missing, do not proceed with the installation, call Trail Master Suspension to obtain needed items.

Product Use Information

As a general rule, the taller a vehicle is the easier it will roll. We strongly recommend, because of rollover possibility, that seat belts and shoulder harness be worn at all times. Avoid situations where a side rollover may occur.

Braking performance and capabilities are decreased when significantly large/heavier tires and wheels are used. Take this into consideration while driving, also, speedometer recalibration is necessary when larger tires are installed.

Do not add, alter, or fabricate any factory or after-market parts which increase vehicle height over the intended height of the Trail Master Suspension product purchased. Mixing with suspension lift voids all warranties. Trail Master Suspension makes no claims regarding lifting devices and excludes any and all implied claims. We will not be responsible for any products that are altered. The only exception to the above policy is combining a Trail Master Suspension torsion key leveling kit with a Performance Accessories body lift system.

12. Using the same precautions and procedures that were used during removal, load the torsion bar enough to install the nut block using the appropriate puller tool. Place the nut block back in the crossmember and start the adjuster bolt. Tighten the adjuster bolt to the same exposed length noted during disassembly. Unload the remove the pulled tool.
13. Lower the vehicle to the floor, manually bounce the front of the vehicle several times enough to settle the suspension.
14. Measure the ride height on each side. To raise the height, tighten the torsion bar adjuster bolt; to lower ride height, lessen the adjuster bolt. The torsion key is capable of increasing the ride height 1-1/2" (mid-size) to 2" (full-size) over *factory* specifications. Do not increase ride height above the specification.
15. Realign the vehicle to factory specifications.

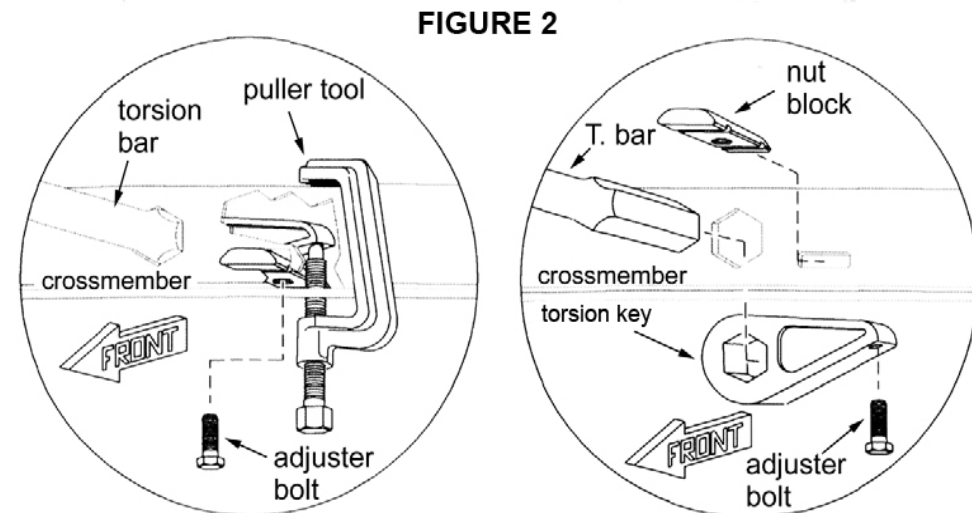

Notice to Dealer and Vehicle Owner

9. Using extreme caution, tighten the puller tool enough to take the load off the adjuster bolt. Remove the adjuster bolt and nut block, then unload the puller tool.
10. Note the orientation of the torsion bar key in relation to the end of the torsion bar. Slide the torsion bar forward, out of the torsion bar crossmember, and set the factory torsion bar key aside. It is not necessary to remove the torsion bars from the vehicle. NOTE: the torsion key should slide easily off the end of the torsion bar. However, depending on the age and use of the vehicle, rust and road debris may prevent easy removal. The installer can use a variety of methods to separate the torsion key if it is “stuck”, but using heat is *not* recommended.
11. Place the Trail Master Suspension torsion key in the torsion bar crossmember, matching the same orientation as the original key. Slide the torsion bar back through the crossmember and into the torsion key. See Figure 2.

NOTE: Various types of puller tools are available, however, due to the extreme loads present in four-wheel drive suspension systems, we have found the two-jaw style tool that clamps to the crossmember tends to slip and damage the crossmember. A C-clamp style puller tool is preferred and available through tool companies such as OTC and Kent Moore.

Any vehicle equipped with any Trail Master Suspension product must have the “Warning to driver” decal installed on the sun visor or dash. The decal is to act a constant reminder for whoever is operating the vehicle of its unique handling characteristics. **INSTALLING DEALER—** Its is your responsibility to install the warning decal and forward these instructions on to the vehicle owner for review and to be kept in the vehicle for service life.

After installation occurs, a qualified alignment facility is required to align the vehicle to factory specs.

NOTES:

- Installation requires a professional Mechanic.
- Have a factory service manual on hand for reference and for appropriate torque specifications.
- **WARNING:** Torsion bars have a tremendous amount of energy stored in them, even with the suspension at full extension travel. Safely loading / unloading the torsion bars requires a special tool. Refer to the factory service manual. Use extreme caution when working with torsion bars and wear all appropriate safety equipment.
- Read through all installation steps before proceeding. If you have questions, contact Trail Master Suspension before beginning the installation.

Installation steps

1. Place the vehicle on a level surface. Prior to beginning, record ride height on each side of the vehicle by measuring from the center of the spindle to a consistent point on the wheel well. Record these measurements for future reference.
2. Put the transmission in Park or 1st gear (manual transmissions) and chock the rear tires.
3. Raise the front of the vehicle using a jack. Raise it enough to completely unload the front suspension. Place a jack stand under each frame rail just behind the lower control arms for the front suspension. Ease the frame down on to the stands, but leave a slight load on the jack as a safety precaution.
4. Verify the front tires are off the ground and that the suspension is unloaded, or at full extension travel.
5. Locate the torsion bar crossmember. There is a bolt on each side of the crossmember that adjusts torsion bar preload. Measure or mark the exposed length of the adjuster bolt for reference during re-assembly. See Figure 1.
6. Position the appropriate torsion bar puller tool on the crossmember. Be sure the top of the puller tool engages the recess present in most crossmembers. Also be sure the lower end of the puller tool engages a recess on the torsion key near the adjuster bolt. See Figure 2.

7. Locate the torsion bar crossmember. There is a bolt on each side of the crossmember that adjusts torsion bar preload. Measure or mark the exposed length of the adjuster bolt for reference during re-assembly. See Figure 1.
8. Position the appropriate torsion bar puller tool on the crossmember. Be sure the top of the puller tool engages the recess present in most crossmembers. Also be sure the lower end of the puller tool engages a recess on the torsion key near the adjuster bolt. See Figure 2.

FIGURE 1 - TORSION BAR ASSEMBLY.

